

MODULE 2a SHORING BASICS

The **Objectives** of this unit are as stated in the adjacent slides. The overall purpose of this unit is to explain **WHY** we build shoring in the **FEMA Response System** in the way that we do. In **SHORING, PART B** the student will be informed as to **HOW** each type of shore is constructed. Then all will be given a chance to become proficient at building them.

BASIC DEFINITION AND PRINCIPALS

Shoring is normally the temporary support of structures during construction, demolition, reconstruction, etc. in order to provide the stability that will protect property as well as workers and the public.

BASIC DEFINITION

SHORING FOR US&R IS THE TEMPORARY SUPPORT OF ONLY THAT PART OF A DAMAGED, COLLAPSED, OR PARTLY COLLAPSED STRUCTURE THAT IS REQUIRED FOR CONDUCTING SEARCH AND/OR RESCUE OPERATIONS AT REDUCED RISK TO THE VICTIMS AND US&R FORCES

A Shoring system is like double funnel. It needs to collect the load with headers/sheathing, deliver it into the post/struts, and then to distribute it safely into the supporting structure below. **A heavily loaded wood post can punch thru a concrete slab etc.**

Shoring should be built as a system that has the following:

- Header beam, wall plate, other element collects load
- Post or other load carrying element that has adjust ability and positive end connections
- Sole plate, bearing plate, or other element to spread the load into the ground or other structure below.
- Lateral bracing to prevent system from racking (becoming parallelogram), and prevent system from buckling (moving sideways).
- Built-in forgiveness (will give warning before failure) **Example: If vertical shore is proportioned properly, (posts with length to width ratio of 25 or less) one can hear the header or sole crush against the post prior to the post starting to fail.**

Minimum level of lateral strength in any vertical support system should be 2% of vertical load, but 10% is desirable where aftershocks are expected.

TERMINAL OBJECTIVES

- The Student shall understand the function and capacity of the various types of Shoring used in US&R to support damaged and collapsed structures
- The Student should also understand why these Shores are constructed in their specific configurations

ENABLING OBJECTIVES

- Understand the Types and amount of Load that needs to be supported by Emergency Shoring
- Understand what needs to be considered when selecting Shoring to support Damaged Structures

ENABLING OBJECTIVES

- Understand how Wood Shoring should be configured so as to respond with a Predictable and Slow Failure Mode
- Discuss the Strength and Load Path for the various types of Vertical, Sloped and Lateral Shoring Systems
- Discuss what types of Shoring Systems are most commonly used to support Light Frame, Heavy Wall, Heavy Floor and Precast buildings

DOUBLE FUNNEL PRINCIPLE

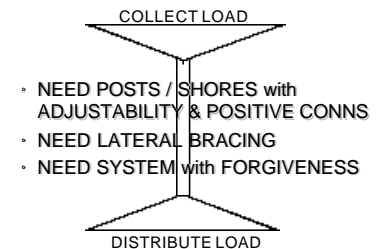

MODULE 2a SHORING BASICS

BASIC DEFINITION AND PRINCIPALS (continued)

Trench Shores provide opposing lateral support - to keep trench/hole etc. from filling in. Design is normally based on at least half the pressure of water (equivalent fluid weight of at least 45PSF per ft. of depth, PCF)

CONSIDERATIONS FOR DESIGN AND SELECTION

WEIGHTS OF COMMON BUILDING MATERIALS.

- Concrete = 150 PCF **PCF = lbs per cubic ft**
- Masonry = 125 PCF **PSF = lbs per square ft**
- Wood = 35 PCF
- Steel = 490 PCF
- Conc/Masonry Rubble=10PSF PER INCH (of thickness)

WEIGHTS OF COMMON BUILDING CONSTRUCTION

- Concrete floors weigh from 90 to 150 PSF
- Steel beam w/ concrete-filled metal deck = 50-70PSF
- Wood floors weigh from 10 to 25 PSF (floors w/ thin concrete fill are 25 PSF or more)
- Add 10 to 15 PSF for wood or metal stud interior walls, each floor level
- Add 10 PSF or more for furniture/contents each floor (more for storage, etc.)
- Add 10 to 20 PSF for Rescuers
 - 10 PSF on large slab that spreads out load
 - 20PSF on wood floors to allow for concentrations

EXAMPLE: shown in slide at right 20ft x 30ft Slab
 Total for 8" concrete slab, 6" of debris, allowance for lights & ceiling, and 10psf for rescuers = 105,000 lbs
 (In this case the 10psf allows for 24-250lb rescuers, which seems to be reasonable)

CAPACITY OF UNDAMAGED, EXISTING CONSTRUCTION.

- One undamaged wood or steel framed floor will support one damaged floor
- It normally takes two undamaged concrete floors to support one damaged floor
- The thickness of rubble/debris on damaged floor must also be taken into account.

WEIGHTS OF COMMON BUILDING MATERIALS

- REINFORCED CONCRETE = 150 PCF
- MASONRY = 125 PCF
- WOOD = 35 PCF
- STEEL = 490 PCF
- CONCRETE OR MASONRY RUBBLE = 10 PSF PER INCH

WEIGHTS OF COMMON BUILDING CONSTRUCTION

- Concrete floors = 90 to 150 psf
 - Light weight concrete is about 80%
- Steel systems w/ conc fill slabs = 50 to 70 psf
- Wood floor = 10 to 25 psf
 - (post 1960 wood floors may have concrete fill)
- Add 10 to 15 psf for wood/metal interior walls
 - each floor
- Add 10 psf or more each floor or furniture etc.
 - More for storage
- Add 10 psf or more for Rescuers

EXAMPLE

- Assume that this 20ft x 30ft classroom has an 8" thick concrete roof with 6" of debris on it
WHAT IS THE TOTAL LOAD TO SHORE ?
 - 8" concrete = 100 psf x 20 x 30 = 60,000 lb
 - 6" debris = 60 psf x 20 x 30 = 36,000 lb
 - Lights, ducts, ceiling, etc. = 5 psf = 3,000 lb
 - Rescuers = 10 psf x 20 x 30 = 6,000 lb*
- | | |
|-------|--------------|
| TOTAL | = 105,000 lb |
| | = 105 Kips |
- * 6,000 lb Rescuers allows for 24 - 250 lb people
 Is this reasonable ? If not use more, this is MINIMUM

GENERAL RULES OF THUMB NORMAL CAPACITY OF UNDAMAGED CONSTRUCTION

- One undamaged wood framed floor will support one damaged wood floor
- One undamaged steel framed floor will support one damaged steel floor
- It takes two undamaged reinforced concrete floors to support one damaged concrete floor

MODULE 2a SHORING BASICS

CONSIDERATIONS FOR DESIGN AND SELECTION continued

SELECTION CONSIDERATIONS

Condition of structure to be supported

Is the floor constructed with concrete beams, solid concrete slab, broken slab, etc.? Does the floor have to support masonry rubble? Does the shoring system need to contain an elaborate spreading system, or need one only to support the main beams? Are we supporting a solid concrete slab/wall or is it a broken masonry wall that needs more of a spreader system?

- **In wood floors** we can normally place our shoring header directly against the bottom of 2x10 or 2x12 joist, but if the floor or roof is constructed using deep, thin trusses, I-joist, or Truss-joist that may be problematical. Deep, thin members should not be shored from the bottom without doing something to keep them from tipping over.
- A solution to this problem is to somehow shore from the top of this type of member, or to provide some way of keeping them from tipping.
- **In steel floors**, beams can be directly shored from the bottom, but steel bar joist present the same problem as wood trusses.

The condition of foundation/support of shoring – solid or soft ground, slab on ground, floor over basement below, rubble, number of un-damaged stories below, determines extent of system.

Availability of shoring materials - pre-plan, local contractors, foreign location.

- For collapsed structures want light, portable, adjustable, reliable, and forgiving shoring system.

NORMAL CAPACITY OF UNDAMAGED CONSTRUCTION

- Useful info for shoring multi-story buildings.
 - shoring should be placed under damaged beams, etc.
 - multi-level shoring should align from story to story
- The thickness of debris from heavy, exterior walls, etc. must also be taken into account
 - In URM buildings, wall debris can easily weigh more than a normal story

SHORING - SELECTION CONSIDERATIONS

- CONDITION OF DAMAGED FLOOR / WALL
 - SOLID WITH CRACKS
 - BADLY CRACKED CONCRETE OR MASONRY/URM
 - WOOD JOIST - WOOD TRUSS
 - STEEL BEAM - STEEL BAR JOIST

SHORING - SELECTION CONSIDERATIONS

- CONDITION OF SUPPORTING SURFACE
 - SOLID GROUND - SLAB ON GROUND
 - RUBBLE COVERED GROUND OR SLAB
 - UNDAMAGED FLOORS IN MULTI-STORY BUILDING
 - BASEMENT - BUT NOW MANY FLOORS BELOW
- AVAILABILITY OF SHORING MATERIALS & LOCAL CONTRACTORS

MODULE 2a SHORING BASICS

CONSIDERATIONS FOR DESIGN AND SELECTION contin.

Damaged/Collapsed buildings often contain lateral as well as vertical instability.

- Building with cracked (damaged) and out of plumb walls/columns require lateral support in proportion to the offset story, (as much as 10 % of weight of building).
- If structure is partly supported by tension structure-like system, horizontal forces are often induced in remaining structure.
- Collapses that have large remaining pieces can be extra dangerous. Interconnected pieces may depend on each other for support. A complicated balancing act to be wary about.
- Collapsed structures containing sloped surfaces are especially difficult, since loads are vertical due to gravity, but contact surfaces are sloped, and therefore, vertical and lateral forces induced in shoring are both very large.
- Total load of structure above can be relatively easily calculated, but where individual load concentrations are being applied is often difficult to determine. A shoring system that will give warning of overload is therefore most desirable.
- It is difficult to decide on the design load when a damaged structure is at rest, but of questionable stability.
 - Should vertical shoring support the weight of the damaged but currently stable floor, or only the weight of rubble resting on it?
 - A four story wood building that is offset one foot in ten in the lower story will require a ten percent stabilizing force, but what additional force should be allowed for wind or aftershock?

SHORING - SELECTION CONSIDERATIONS

- Damaged buildings often contain vertical as well as lateral instabilities
- Uncollapsed buildings have been 10% out of plumb in one story (requires lateral shoring to support 10% of total weight of building + aftershock)
- The previously discussed Catenary systems may induce horizontal forces in remainder of building

SHORING - SELECTION CONSIDERATIONS

- Collapses with large pieces may have unseen interdependencies
- Sloped floors & walls are difficult.
 - Loads are vertical due to gravity -
 - Contact surfaces are sloped & lateral forces need to be considered and resisted.

TOTAL LOAD OF STRUCTURE - EASILY CALCULATED

- Don't know where load is concentrated
- Similar to mine collapse - unknown arch action
- Shoring system must give warning of overload
- Brittle failure mode is very undesirable

MODULE 2a SHORING BASICS

VERTICAL SHORING SYSTEMS

We will now discuss to various types of vertical shoring systems that have been successfully used in US&R, as listed on adjacent slide.

- These systems are primarily intended to provide vertical support, but should all have some lateral bracing for stability. (2% min., 10% reasonable) However, often, individual vertical supports are initially installed without lateral bracing, in order reduce risk while constructing a well-braced system.

WOOD CAN GIVE WARNING OF OVERLOAD

- As previously stated, a most desirable property for emergency shoring is to have a system that will give a warning when it is becoming overloaded, so that one can mitigate the situation. Wood has a built-in (or more accurately, grown-in) property that can be used in our systems to give a noisy indication of high stress.
- As explained in the adjacent slide, most commercial timber grows in a way that produces softer, spring fibers and harder, summer fibers. By configuring a shoring system such that the longitudinal grain bears on the cross grain of wood, and the vertical piece is kept short enough that it won't buckle, we can cause the cross grain to crush.
- We can hear and observe this crushing that will occur when the bearing stress is somewhere between 500 and 1000 psi, depending on species of timber.
- We want to avoid the condition where the wood post fails in buckling – a sudden, brittle failure mode. In order to do this we need to keep the length to width ratio (L/D) of a wood post to less than 25 for the most common lumber used in the U.S.
- **Example: 4x4 length for L/D of 25 = 25x3.5 = 88" = 8ft**
- As will be discussed next, one can use posts that have L/D ratios up to 50. However, in critical emergency shoring situations where the load is not known with any degree of accuracy and we want to have a system that will give us warning, it will be more prudent to stay within the L/D = 25 limit.

VERTICAL SHORING SYSTEMS

- WOOD POSTS
- ELLIS CLAMPS
- T SHORES
- WINDOW/DOOR
- LACED POSTS
- CRIBBING
- STEEL PIPE
- TRENCH SHORES
- METAL FRAMES & JOIST
- PNEUMATIC SHORES
- SPECIALTY SHORES
- SLOPED SURFACES

USE UNIQUE PROPERTY OF TIMBER TO PROVIDE WARNING OF OVERLOAD

- Growth pattern of Tree
- Rapid growth in spring deposits relatively soft fiber
- Slower growth rate in summer deposits more dense fiber
- If load end grain, crushing strength is determined by summerwood
- If load is on side (crossgrain), soft springwood determines strength
- Crossgrain bearing failure is slow & noisy - (gives warning)

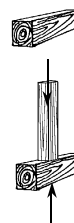

CAPACITY OF WOOD POSTS

- Slenderness (L/D) determines the buckling strength of a wood post
 - Buckling failure is sudden and undesirable
 - The maximum allowable L/D is 50
- For better failure mode posts should be constructed so their L/D is less than 25
 - This will insure that crossgrain crushing can occur and be observed at a load that is lower than the Buckling Load.

MODULE 2a SHORING BASICS

CAPACITY OF WOOD POSTS

- Unless kept relatively short, a post's strength depends on buckling and varies relative to its length and the modulus of elasticity (E).
 - Square Posts $P/A \text{ allow} = .3E/(L/D) \text{ squared}$
 - Round Posts $P/A \text{ allow} = .23E/(L/D) \text{ squared}$.
 - (E varies from 1M to 1.8M PSI depending on wood species.
 - (P/A = compression stress) PSI = lbs per square inch
 - (L = Length, D = Least width or Dia., L/D max = 50)
 - As stated on pg. 2, if want to hear warning of failure, it is better to limit L/D of posts in vertical shores to 25.
 - **Example 4x4 max. length = 50x3.5 = 175" = 14.5ft**
 - **4x4 length for L/D of 25 = 25x3.5 = 88" = 8ft**
- The strength of a wood post system is determined by:
 - Perpendicular to grain bearing on the header or sole plate (allowable bearing stress varies from 300 PSI to 700PSI depending on wood species)
 - Vertical capacity of the posts.
 - Strength of header beam and/or sole plate.
 - Strength of ground or structure below sole plate.
 - If posts are kept short (**8 ft for 4x4, 12 ft for 6x6**) the system will give warning of failure by crushing the softer crossgrain (spring wood) at the bearing of the post on the sill or header.
- Douglas Fir or Southern Pine are the most common types of structural timber used in the U.S. Average values for these species are:
 - E = 1,600,000 PSI
 - Compression parallel to grain = 1100 PSI
 - Compression perpendicular to grain = 600 PSI
- The capacity of header beam and sole plate is determined by bending an/or horizontal shear strength. Average values for Douglas Fir and Southern Pine are:
 - Fb = extreme fiber bending stress = 1500 PSI
 - Fh = horizontal shear stress = 90 PSI
- The capacity of a system supported on the ground may be limited by the soil bearing capacity and transverse spreading of load may be desirable to avoid excess settlement.

CAPACITY OF WOOD POSTS

- Slenderness (L/D) determines the buckling strength of a wood post
 - Buckling failure is sudden and undesirable
 - The maximum allowable L/D is 50
- For better failure mode posts should be constructed so their L/D is less than 25
 - This will insure that crossgrain crushing can occur and be observed at a load that is lower than the Buckling Load.

CAPACITY OF WOOD POSTS

- For L/D to be 25 or Less
 - 4 x 4 should be kept shorter than 8 feet
 - 6 x 6 should be kept shorter than 12 feet
- This is not always possible
- If a post is properly braced at its mid-height, it's *Effective* length is half it's Total length.
 - Bracing must be placed in N-S as well as E-W direction and properly nailed
- *FEMA, US&R shoring has lots of bracing*

MODULE 2a SHORING BASICS

CAPACITY OF WOOD POSTS (continued)

- These systems are normally made adjustable by cutting and shimming with full bearing, opposing, wood wedges.
- All posts should be positively attached at top and bottom.
 - This requirement along with the need for diagonal bracing limits the ability to readjust the wedges after making these connections.
 - If additional adjustment or re-tightening is required (such as after aftershocks), one may add shims directly under the load or under to sole plate.
- All wood post systems should have diagonal wood bracing, in north-south and east-west direction if possible.
 - Bracing should be designed for at least 2% of the vertical capacity of the shoring system.
 - (10% if aftershocks are possible.)

VERTICAL SHORES – NORMAL WOOD POST SYSTEM

- The graphic on the following page (SHOR-1) illustrates the construction and capacity of the Wood Post, Vertical Shore.
 - Connections at top & bottoms of posts are nailed gussets
 - Diagonal braces are nailed to each post and also provide top & bottom connections for exterior posts.
 - These shores should be built in pairs (8ft o.c. max) with X bracing placed between them (aftershock conditions)
- The connection at the top & bottom of exterior posts is of special interest, since the diagonal must be carefully positioned to transfer the Lateral Load (see Load Path slides).
 - The diagonal must also be nailed to the header, post, sill, and also confine the wedges.
 - A gusset needs to be placed on the opposite side of posts at bottom to reduce risk of sole roll-over and wedge pop-out.
- The table below the Vertical Shore diagram gives values for two systems based on both post and header beams being stressed at their MAXIMUM allowable wood values.
 - The left hand column gives the maximum value for EACH POST at the listed height (listed in left column)
 - The spacing of posts is the MAXIMUM distance that the header can span when posts are loaded to their MAXIMUM.
 - If post spacing is reduced, the capacity of system is increased
 - If the size of the header is reduced, the distance between posts must be reduced proportionally

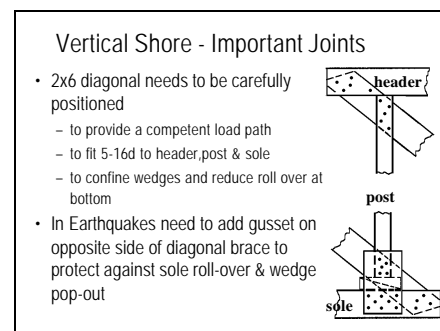
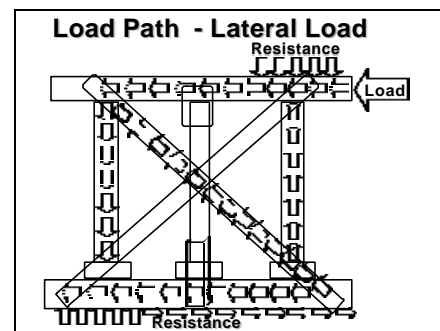
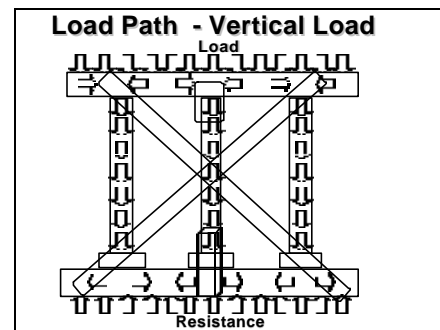
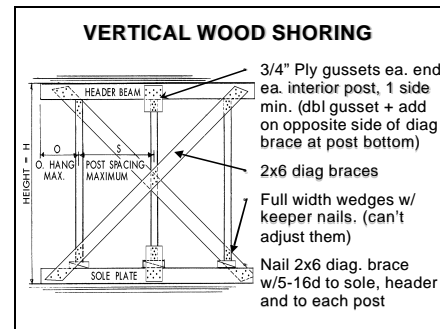

(If use 4x4 header instead of 4x8, span "S" should be half as much).

MODULE 2a SHORING BASICS

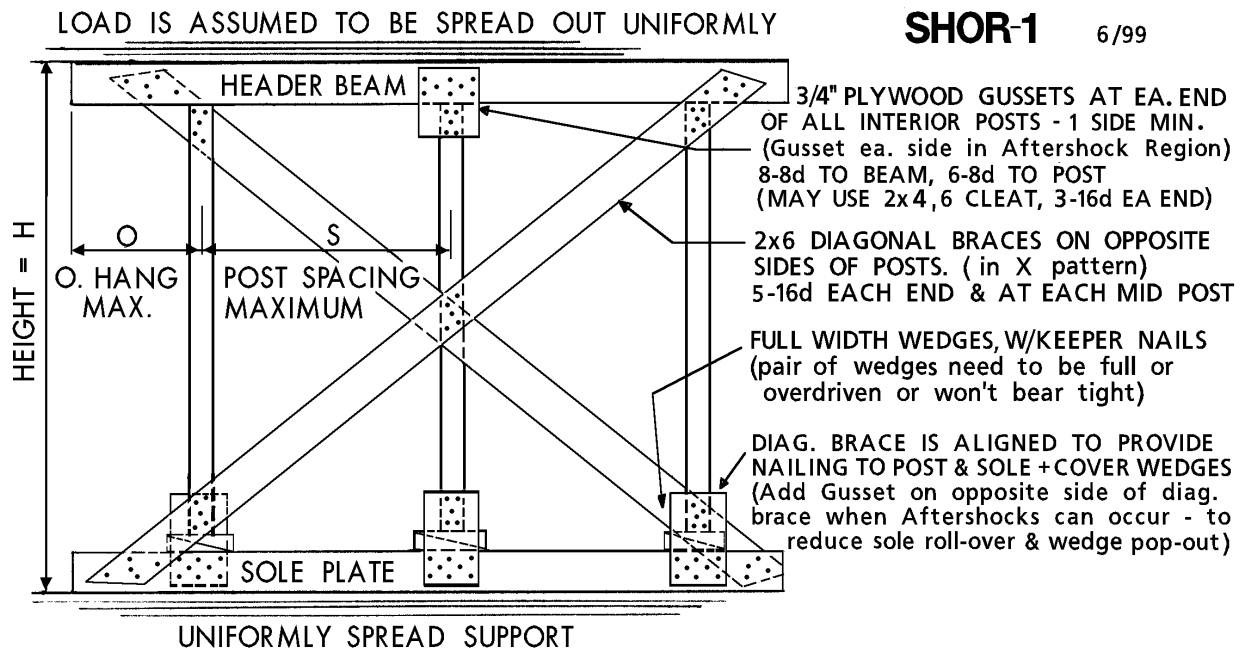

4x4 POST SYSTEM W/4x8 HEADER BEAM & SOLE PLATES

HEIGHT = H	POST SPACING = S	OVERHANG = O	CAPACITY OF EACH POST
8'-0"	4'-0"	2'-0"	8,000 LB *
10'-0"	5'-0"	2'-6"	5,000 LB
12'-0"	6'-0"	3'-0"	3,500 LB

6x6 POST SYSTEM W/6x12 HEADER BEAM & SOLE PLATES

HEIGHT = H	POST SPACING = S	OVERHANG = O	CAPACITY OF EACH POST
12'-0"	4'-0"	2'-0"	20,000 LB *
16'-0"	5'-0"	2'-6"	12,000 LB
20'-0"	6'-0"	3'-0"	7,500 LB

BASIC ASSUMPTIONS :

(* = Limited by 660 psi crossgrainbearing)

- Configurations shown are for MAXIMUM spacing of posts so that capacity of header & sole plate just matches capacity of posts.
- Spacing of POSTS may be closer than shown to increase system capacity (per foot)
- If HEADER/SOLE is reduced, the capacity of each POST should be reduced in proportion to the reduction in HEADER DEPTH (change 6x12 to 6x6, capacity is 1/2)

VALUES GIVEN FOR ALL WOOD SHORES IN THIS TEXT HAVE AN APPROXIMATE FACTOR OF SAFETY OF 2 TO 1 IF NO. 1 DOUGLAS FIR OR SOUTHERN PINE ARE USED. PIECES SHOULD BE SELECTED FOR GOOD GRAIN (MIN. OF 8 RINGS PER INCH, SLOPE OF GRAIN NOT GREATER THAN 8 TO 1, AND HAVING 1 1/2 INCH OR SMALLER TIGHT KNOTS / 3/4" MAX LOOSE KNOTS)

MODULE 2a SHORING BASICS

VERTICAL SHORING SYSTEMS (continued)

ELLIS CLAMP - WOOD POST SYSTEMS

- 4 x 4 posts can be assembled with Ellis Clamps that give them adjustable length. The failure mode of these assemblies is usually indicated by the crushing of the wood under the clamps, which gives the system some forgiveness. (If shores are 10 ft. or less in height)
- These shores use more lumber than single posts, but they can be very useful when working with short 4x4's.

ELLIS SHORES - ADJUSTABLE 4x4

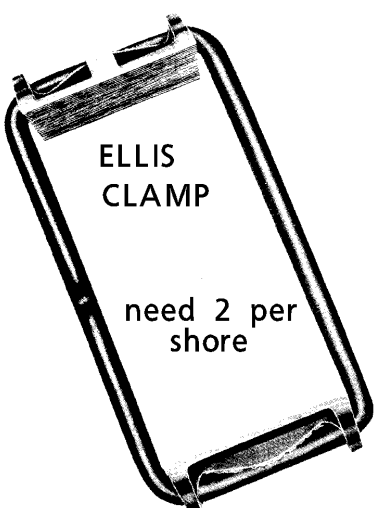

ELLIS JACK
 makes leveling of shores and purlins simple. The Jack grips the wood of the lower shore member and the upper shore member is raised about one inch per stroke through the lifting pressure of the cam at the anchored end of the Jack handle.

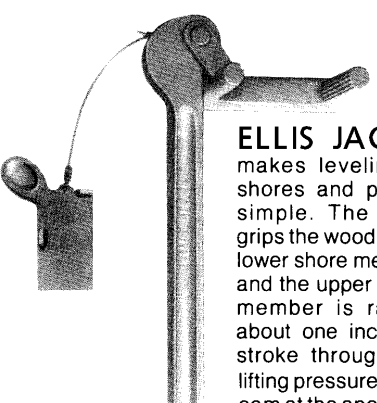

How to Use Ellis Shores:
 First, get the proper length lumber to make an Ellis Shore of the desired height — that being a 7' lower shore member and an Ellis Stick of the proper length. The sketches at the right give some suggestions for best results in the operation of Ellis Shores. The picture at the left shows a man raising the upper shore member to the approximate shore height, final adjustment is made with the Ellis Jack. When the desired height is obtained, the clamps should be tapped down (a hammer lug is provided on the clamp plate) to seat them and a safety nail is driven in the shore above each plate. This nail does not support any load, but simply keeps the clamps from vibrating loose.

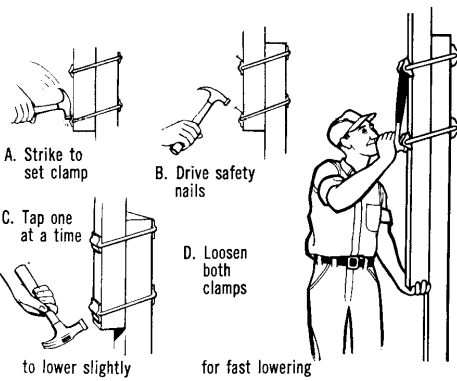

ALLOWABLE LOAD CHART

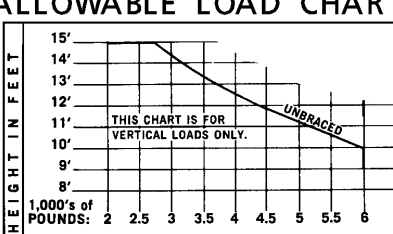

ELLIS CLAMPS MAKE A PAIR OF 4x4 POSTS INTO AN ADJUSTABLE 4x4 SHORE
 Max allowable load is 6000 lbs for shore that is 10ft or shorter with a factor of safety of more than 2 (based on No.1 Doug. Fir/So. Pine)

SHOR-2

6/99

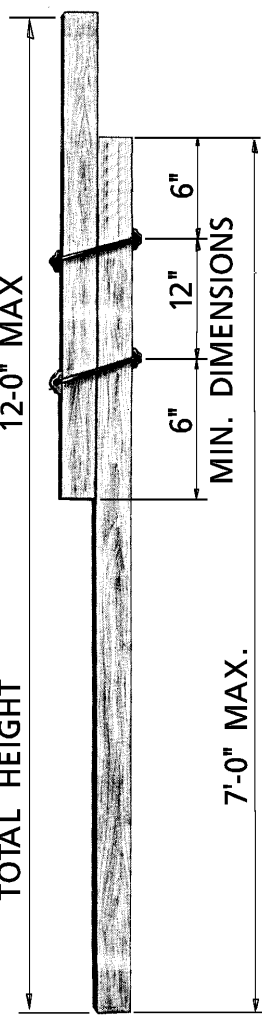

MODULE 2a SHORING BASICS

VERTICAL SHORING SYSTEMS (continued)

ELLIS CLAMP - WOOD POST SYSTEMS (continued)

- Metal, adjustable post feet for 4 x 4 & 6 x 6 are made by Ellis and called Screw Jacks. The foot base plate has nail holes for positive attachment.

T - SPOT SHORE

- This type shore is used for initial stabilization of dangerous areas where fully braced systems (such as Vertical Shores) are to be constructed.
 - They provide temporary support of damaged floors, but they are basically unstable.
 - They can only support loads that are balanced about the vertical post, and therefore the header needs to be kept to a maximum of 3 feet long.
- The capacity of the 4x4 post depends on length as in Vertical Shores (8ft long 4x4 safely supports 8000lb)
- They are normally installed with Wedges and a Sole Plate to spread the load and tighten the shore against the load .

WINDOW & DOOR SHORES

- These Shores have been constructed by Firefighters for years.
- They are used mostly in URM buildings to confine and support loose masonry over openings in the URM walls.
 - They are quite complicated if all corners are properly connected and wedges are confined
 - They may also be used in Wood or other buildings where door or window headers have been damaged.
- The capacity of the wood posts (which are usually short) usually depends on the cross grain bearing strength (between 300 and 700psi depending on wood species)
 - A rule of thumb for headers size is to make the depth the same in inches as the opening width in feet.
 - The header width should be 6 inches for thick, URM walls, but may be 4 inches for thinner walls, such as wood and hollow concrete block (cinder block)
- A simpler, pre-constructed configuration is shown in adjacent slide, which uses shims over header and at one side
 - It can be built in safe area and possibly reused

SCREW JACK by ELLIS

- Adjustable metal foot for 4x4 and 6x6 wood posts
- 6 inch adjustment - set half way to get 3 in. up & down
- Metal Foot is stronger than wood post
- Use sill beam to spread load



T - SPOT SHORE

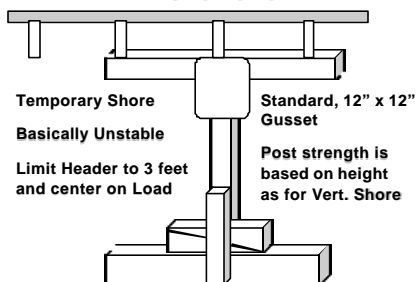

WINDOW / DOOR SHORE (too complicated ?)

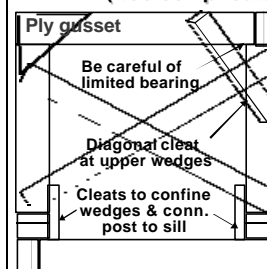

- Used for opngs in URM walls
- Capacity of short posts based on Bearing Strength
- Header should be 1" deep for each 1' of opng width
- X bracing may be removed for access

ALT - WINDOW / DOOR SHORE

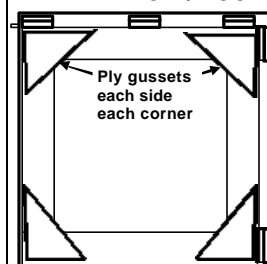

- Pre-construct as box-frame, 1 1/2" min. less than opng.
- Add wedges on one side at top & bottom. then shim above header as reqd.
- Add diag. Braces if wall is racked, & access isn't reqd.

MODULE 2a SHORING BASICS

LACED POSTS

- Four posts may be placed in a square pattern and laced together with 2x4 or 2x6 horizontal and diagonal bracing.
- The strength of each post may then be calculated on the basis of the length/height between lateral braces (horizontals)
- Header beams and sole plates usually are required to collect and distribute the load, as with any system.
- The space inside the laced posts may be useful as a safe haven, since it is relatively strong and one may climb in relatively quickly
- Laced Post Systems are most effectively constructed by first building two, 2 post vertical shores with appropriate connections and then lacing them together.
- The connections between diagonals and header/sole need to be made with as much care as for the Vertical Post Shore, since the 2x4 diagonal must be nailed properly to header, post, sole, and confine the wedges as shown at the right.
 - A gusset is, again, useful opposite the diagonal to sole connection to guard against roll-over and wedge pop-out.

CRIBBING

- Multi member lay-up of 4x4 to 8x8 lumber in two or three member per layer configuration.
- Capacity is determined by perpendicular to grain load on sum of all bearing surfaces.
- Stability is dependent on height to width of crib and should not exceed 3 to 1.
 - Need to overlap corners a minimum of 4" to guard against splitting off corners of individual pieces that can negatively impact overall stability.
- Cribs used by contractors (or in short-term emergencies) often rely only on the friction between bearings for lateral strength, not sufficient for aftershocks.
- Individual pieces may be notched like Lincoln logs, to provide lateral resistance in addition to the friction between pieces. Metal clips may also be used to improve lateral strength, as well as diagonal braces between pairs of cribs.

LACED POSTS

- Wood Posts spaced 3 to 5 ft
- Increase long post capacity due to short effective length
- Add 2x4 lacing, 3-16d @ end
 - 3bays bracing if over 12ft high
- Need Header & Sole Beams
 - connections are similar to vertical shore (see next)
- Height NOT exceed 4 x width
- Can use as Safe Haven
- 4 - 4x4x16'- 0" = 32,000#
- 4 - 6x6x20'- 0" = 80,000#
- Based on 660psi bearing

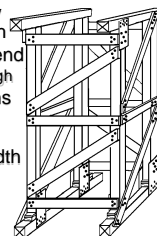

LACED POSTS - CONNECTIONS

- Need to carefully place diagonal at post to beam & post to sole
 - nail 3-16d to beam & post at top
 - nail 3-16d to sole & post at bottom
 - + confine wedges
- Use gusset, one side at other post to beam & each side to sole (+ opposite side diagonal)
 - 5-8d to post
 - 8-8d to beam & sole

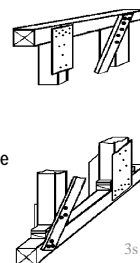

WOOD CRIBBING

- Capacity based on crossgrain bearing area of system
- Allow stress varies from 200 to 1000psi for wood species
- For 2 member x 2 member crib
 - 4x4 capacity = 24,000# (500psi)
 - 6x6 capacity = 60,000#
- Limit Height to Width to 3 to 1
- Overlap corners by 4" to assure slow, crushing failure

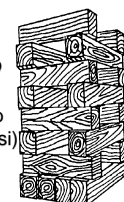

MODULE 2a SHORING BASICS

VERTICAL SHORING SYSTEMS (continued)

CRIBBING – CAPACITY AND LAYOUT

CAPACITY BASED ON CROSSGRAIN BEARING
 (VARIES FROM 200 PSI TO 1000 PSI DEPENDING ON WOOD SPECIES
 500 PSI IS USED HERE - EXAMPLE $500 \times 3.5 \times 3.5 \times 4 = 24,000$)
FOR 2 MEMBER x 2 MEMBER LAYOUT

4 x 4 CRIB CAPACITY = 24,000 LBS (12 TONS)
 6 x 6 CRIB CAPACITY = 60,000 LBS (30 TONS)

FOR 3 MEMBER x 3 MEMBER CRIB, CAPACITY IS 9/4 AS MUCH
 $500 \times 3.5" \times 3.5" \times 9 = 55,000$, $500 \times 5.5" \times 5.5" \times 9 = 136,000$

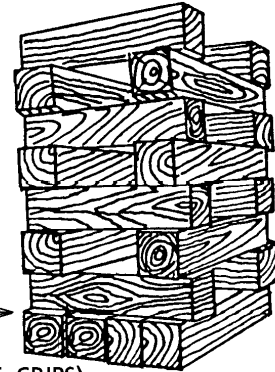

- BOTTOM LAYER SHOULD BE SOLID TO SPREAD THE LOAD ESPECIALLY ON SOIL OR ASPHALT PAVING
- LIMIT HEIGHT TO 3 TIMES WIDTH (SHORTEST WIDTH FOR NON-SQUARE CRIBS)
- OVERLAP CORNERS BY 4 INCHES TO ASSURE SLOW CRUSH TYPE FAILURE

SHOR-4r 9/98

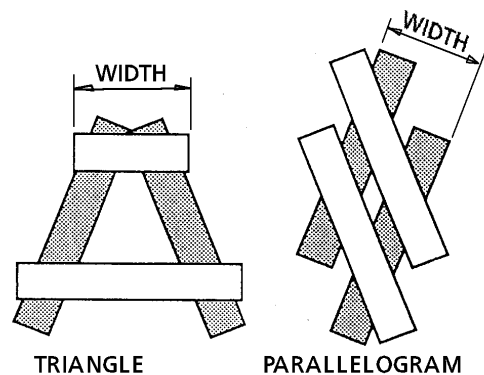
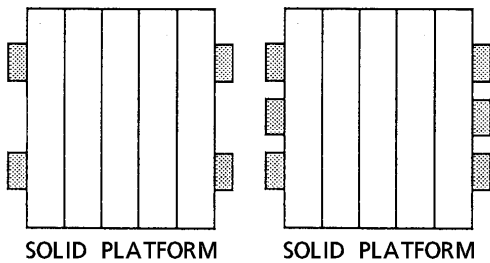
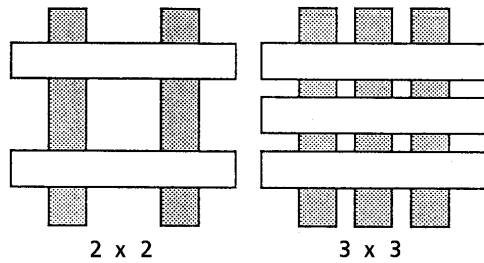

BOTH ARE NOT VERY STABLE, KEEP HEIGHT TO WIDTH WITHIN 1 TO 1

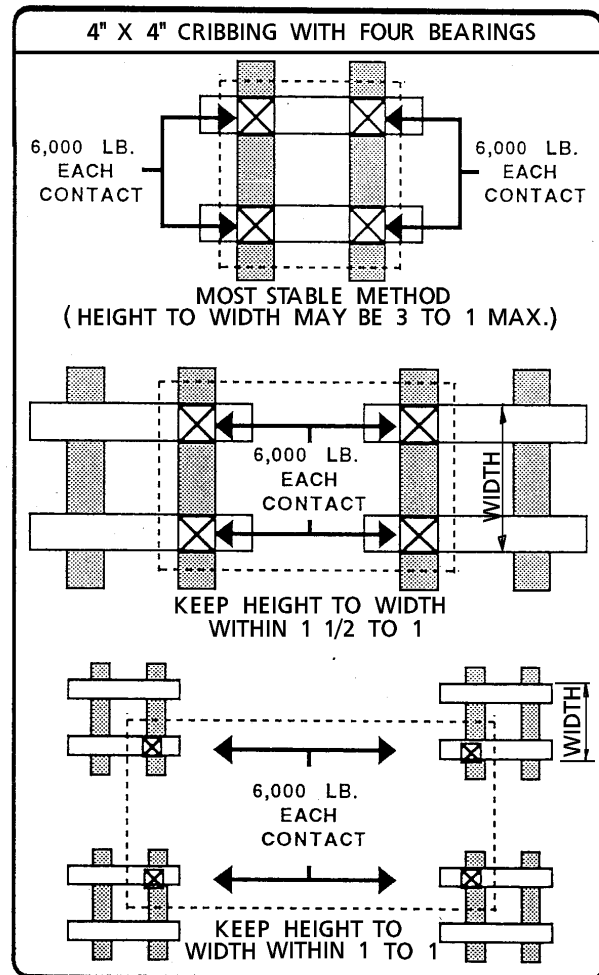

MODULE 2a SHORING BASICS

CRIBBING DEFLECTION PROPERTIES SHOR -4a

from Bureau of Mines Report of Investigation/1991 RI/9341
 by Thomas M. Barczak & Carol Tasillo U.S. Dept of Interior

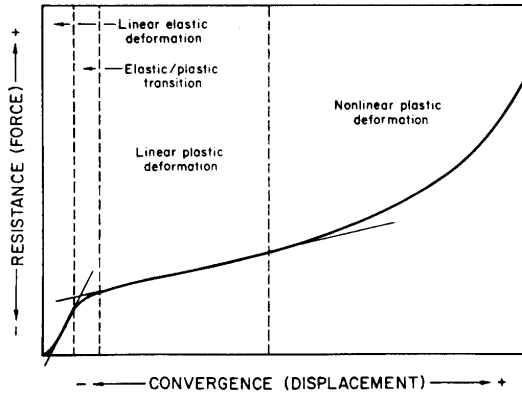

GENERAL FORCE TO DISPLACEMENT RELATIONSHIP

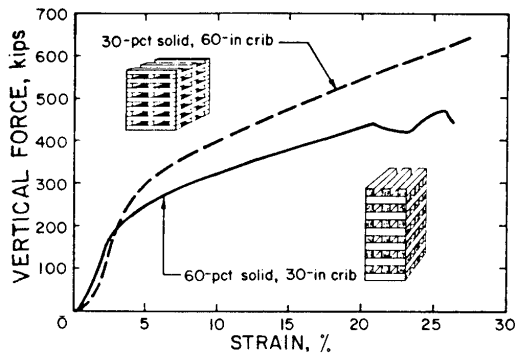

COMPARE SAME AREA BUT DIFFERENT HEIGHT TO WIDTH (ASPECT RATIO)

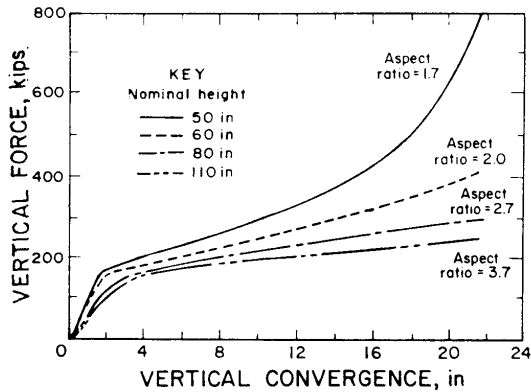
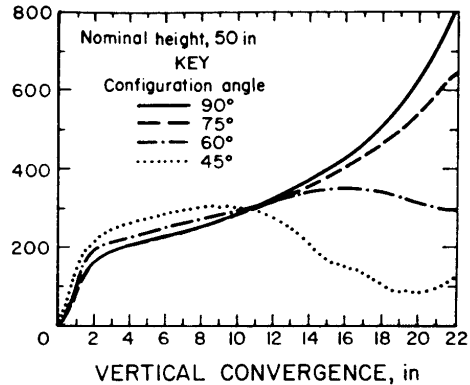

EFFECT OF CHANGE IN ASPECT RATIO

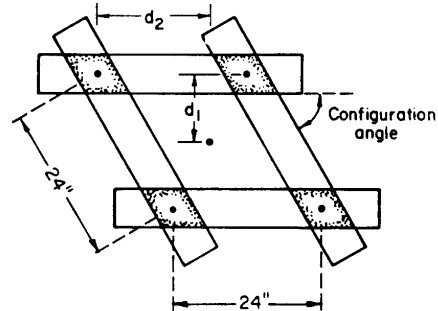

EFFECT OF MOMENT OF INERTIA CHANGES DUE TO CHANGE IN CONFIGURATION ANGLE

MODULE 2a SHORING BASICS

VERTICAL SHORING SYSTEMS (continued)

CRIBBING (continued)

- Failure is slow, noisy crushing of softer spring wood fibers, which make system very desirable for unknown loading of US&R work. In order to assure this desirable failure mode, the crib corners must be made by overlapping the individual pieces by four inches as previously mentioned.
- Solid levels can be placed within the crib to support a jack or spread the load at the ground level.
- Heavily loaded cribbing can crush so that it will loose from 10% to 20% of it's height.
 - This is a good thing as far as providing warning of overload, but may present problems regarding stability and the need to keep the system tight.
- Shrinkage of green lumber will cause crib to shorten and they should be checked daily for tightness.
- Cribs may be used to support sloped surfaces as will be discussed later

STEEL PIPE SYSTEMS

- Pipe capacity depends on buckling strength.
- $P/A \text{ allow} = 0.5E/(L/R) \text{ squared}$
 $E = 29,000,000 \text{ PSI}$
(L = length; R = radius of gyration = average radius of pipe)
- Retractable pipe shores are normally adjustable by screw end and/or sleeve and pin. They may have square steel feet that may even have slope adjustment and nail holes for attachment.
- Pipe shores used for bracing tilt-up concrete walls come in lengths up to 30 feet and have rated capacities listed in tables supplied by rental companies.
- Pipe systems are often used with wood spreader beams and sills, which could limit their capacity. Engineers should be used to design these systems.

WOOD CRIBBING

- Capacity based on crossgrain bearing area of system
- Allow stress varies from 200 to 1000psi for wood species
- For 2 member x 2 member crib
4x4 capacity = 24,000# (500psi)
6x6 capacity = 60,000#
- Limit Height to Width to 3 to 1
- Overlap corners by 4" to assure slow, crushing failure

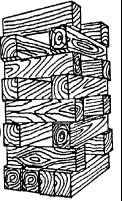

PIPE SHORES

- Not in US&R Equipment Cache
- Rent from Concrete Service Co.
- Capacity based on Diameter & Length of shore (L/r)
- 2" dia. pipe x 10-0 = 6,000#
1 1/2" dia. x 7-0 = 5,000#
- Capacity of system using wood header & sole may depend on base plate area

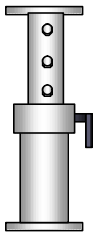

4s

MODULE 2a SHORING BASICS

VERTICAL SHORING SYSTEMS (continued)

TRENCH JACKS

- Vary from about two to more than eight feet long and normally have a rated capacity. They are intended to support the opposing sides of a trench, with the addition of spreaders & sheathing
- May be used as initial, unbraced shoring to permit building of more stable system.
- If used as only system they will need to be connected to spreaders at top and bottom and should be laterally braced.

DIAGONALLY BRACED METAL FRAMES

- Steel and aluminum tubular frames are available in capacities up to 50,000lb. per two post frame. They have adjustable height and spreader systems. They may be stacked and guyed to reach great heights, and have diagonal bracing members.

ALUMA BEAMS

- These are light gage, shaped aluminum joist or beams that are normally used as shoring for wet concrete.
- They have been used to construct shelters from falling debris, as plywood sheathing can be placed between the Aluma Beams and nailed too them to provide a surface that is quite flexible but strong.
- The flexibility of the aluminum (3 times that of a similar steel structure) is ideal for catching falling objects, since the flexibility reduces the strength required for the CATCH structure.

PNEUMATIC SHORES

- Lightweight aluminum pneumatic piston ram shore, which is highly adjustable with ranges up to 16 ft. They can be configured with various end connections (see slide).

TRENCH JACKS

- Adjustable screw type can be used either vertical or horizontal
- Similar capacity to pipe shores
- System may be limited by end bearing area
- All pipes should be Schedule 40



ALUMINUM FRAMES & JOIST

- Available in 20k per 2 leg frame up to 50k
- Capacity of frame may depend on foot bearing plate
- AlumaBeams have wood nailer & can span up to 20' - Have been used as shelter

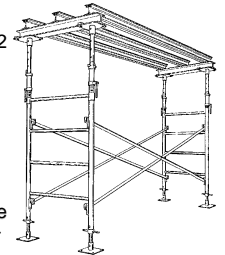

2s

ALUMA BEAMS

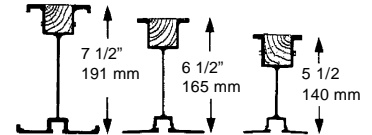

- Available from Concrete Supply (Burke)
- Up to 20 ft spans - use Plywd Sheathing
- Good Dynamic Properties to stop falling objects more slowly - absorb energy

3s

PNEUMATIC SHORES

- Adjustable shore with length up to 16 ft - Manufactured by Airshore & Paratech
- Have swivel & other feet
- Should be set manually using adjustable collar or sleeve nut - DON'T USE AIR SET IN US&R
- Working Load decreases with length and should be based on tests using swivel ends
- Best use is as initial shore

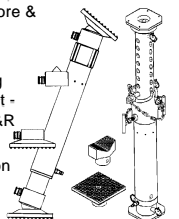

2s

MODULE 2a SHORING BASICS

VERTICAL SHORING SYSTEMS (continued)

PNEUMATIC SHORES (continued)

- When used in trenches, these shores are initially set with pressurized air. After securing the shore in place with a large locking nut or steel pins with collar, the safe working load can range from 20,000 lbs. for four-foot shore to 3500 lbs. for ten-foot shore. Load charts for the two leading manufactures are listed in the 1998 rev. of the US&R Structural Specialist FOG. (Safe loading should be based on Pinned/swivel end connections)
- These shores are used without air in US&R, so as not to apply any sudden pressure to a damaged structure. The sleeve nut or steel pins are used to adjust length. They may be included in a system with headers, sole plate, & beam and bracing, but are considered most useful as individual, temporary shores that allow a braced system to be installed at reduced risk.

SPECIALTY SHORES (Airbags are lifting device - not shores)

- **AIRBAGS** – tough neoprene bags that come in sizes from six inches to thirty-six inches square. They can be pressurized to lift very heavy objects a short distance and often are helpful in releasing an entrapped victim. One must be careful to remember that they can be punctured by rebar, and that objects that are lifted must be laterally restrained by other means, since the bags have little lateral strength. Airbags should always be used while being backed-up with some other system to protect against a puncture failure.
- **STEEL OR REINFORCED CONCRETE CULVERT** sections could be considered as a protection device for entry thru an area where protection from smaller falling hazards was required.
- **SHORING AT COLUMN/SLAB CONNECTIONS** - The danger of a punching shear failure occurring at a flat slab/column joint is often present due to heavy debris loading on slabs that do not collapse initially. Since most of the cracking that warns of this type of collapse hazard is on the top of the slab and may be covered by the debris, it may be prudent to increase the column's periphery by adding vertical shoring on all four sides. Shoring consisting of vertical posts could be used and laterally braced back to the column. All the normal problems i.e. what's the load, supporting system etc. need to be considered.

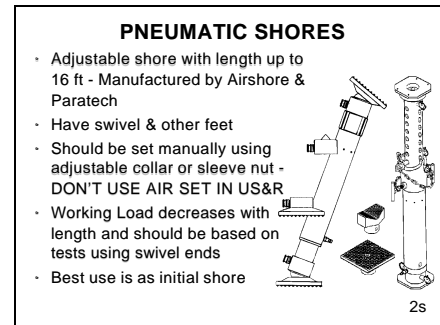

MODULE 2a SHORING BASICS

VERTICAL SHORES ON SLOPED SURFACES

■ In normal sloped roof construction, sloped rafters are fabricated with horizontal bearings cut-in, so that the vertical, gravity load can be directly transferred into the supporting structure.

■ When attempting to shore a damaged, sloped floor, however, the vertical, gravity load is transferred from structure to shoring thru a sloped surface where two forces are generated.

- A force that is Perpendicular to the sloped surface, and
- A force that will act down the Slope – Slope Force

■ In many cases, especially for reinforced concrete slabs, the Slope Force may be assumed to be resisted by:

- The connection of the Sloped Floor to the remaining structure at the top, or
- The Sloped Floor is firmly embedded in rubble at the bottom.
- When this is the case, the **Perpendicular to Slope Method** shores may be used to successfully support the sloped floor.

■ Two variations of the Perpendicular type shore are shown on SHOR-92.

- Type 1 may be placed on an earth surface, with bearings that are cut into ground, perpendicular to the shores.
- Type 2 is intended to be built on hard surfaces, and uses cleats nailed to the Sole, which is in turn, anchored

■ When the sloped floor is not reliably connected to the remaining structure or embedded in rubble, the **Sloped Friction Method** shore should be used.

- In this case the Perpendicular and Slope force are combined within the system to allow the shore posts to be placed in a vertical alignment.
- Since the reliance on friction, especially during Aftershocks may be problematical, the header should be positively attached to the sloped floor, especially if floor is sloped greater than 5%.

- Small bars ($\frac{1}{2}$ " to $\frac{3}{4}$ " diameter) could be carefully drilled into bottom of slab (through pre-drilled holes in header) and held in place with epoxy (or by interference fit)
- Shore could bear on sides of beams or other protrusions.

SHORES FOR SLOPED FLOORS

In Normal Construction, one cuts Level Bearings in Wood Rafters (Birds Mouth)

WE CAN'T DO THIS

UNSAFE AND NOT PRACTICAL

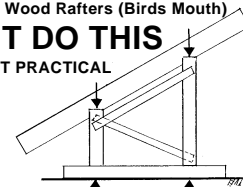

METHOD USED to CONSTRUCT a SLOPED ROOF
 Since bearings are level, loads are transferred vertically without any sloped forces being generated

1s

SHORES FOR SLOPED FLOORS Perpendicular to Slope Method

Bearing load direction is perpendicular to contact surface between shore and structure

Gravity Load may be connected to remaining structure

Concrete Slab to remaining structure

Sloped force resisted here or by remaining structure

Slope force depends on degree of slope

Force in shore is perpendicular to contact surface *

To shore sloped surfaces we must provide a system that will resist both vertical & lateral forces
 * = What about friction between shore & slab ?

SHORES FOR SLOPED FLOORS

What to do if Sloped floor is NOT connected to Remaining Structure or Embedded in Rubble ?

System with shaped top - vertical shores, cut to mate with cleats & header will transfer both the sloped & perpendicular forces

Gravity Load

Concrete Slab

Drill-ins

Gravity load in floor is resisted by sloped friction

Force + Force perpendicular to Sloped surface

No Reliable Resistance

Vert. load resisted by ground

Anchor

SLOPED FRICTION METHOD
 (For slopes over 5% need Connection between Header & Slab)

MODULE 2a SHORING BASICS

VERTICAL SHORES ON SLOPED SURFACE (continued)

SHORES FOR SLOPED FLOORS

SHOR-8

9/99

Bearing load direction is perpendicular to contact surface between shore/header and sloped floor or roof

Gravity Load (always vertical)

Concrete floor slab

Sloped force may be resisted here or by other attachment to remaining structure

Slope force depends on degree of slope

Force in Shore is Assumed to be perpendicular to contact surface (assumes no friction)

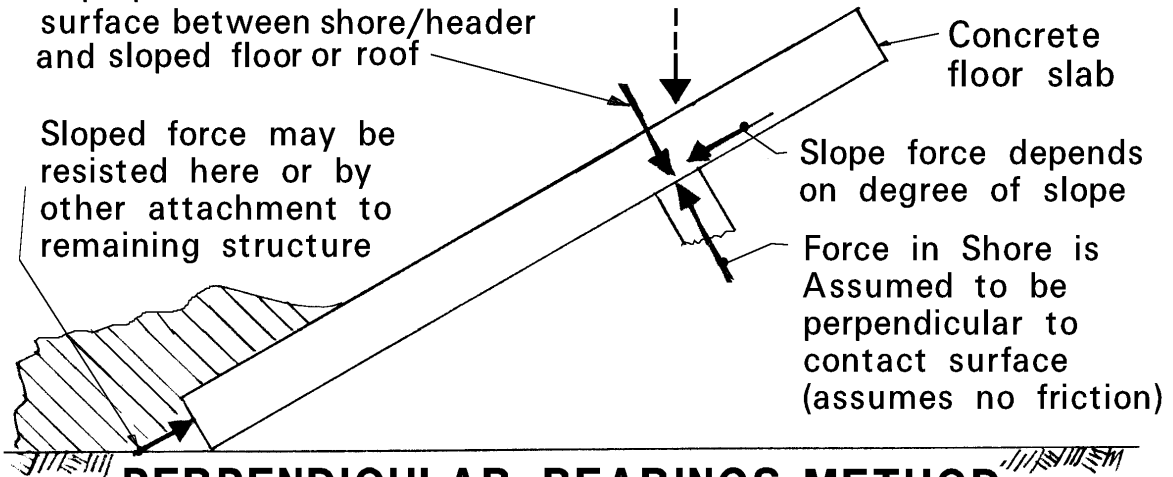

PERPENDICULAR BEARINGS METHOD

(based on assumption that slope force is resisted by attachment to remaining structure or sloped floor is firmly embedded in rubble)

See Type 1 and Type 2 on following Page

If sloped floor is not connected to remaining structure and not embedded in rubble, a system with shaped top - Vertical Shores cut to mate with cleats and header will transfer the sloped and perpendicular forces

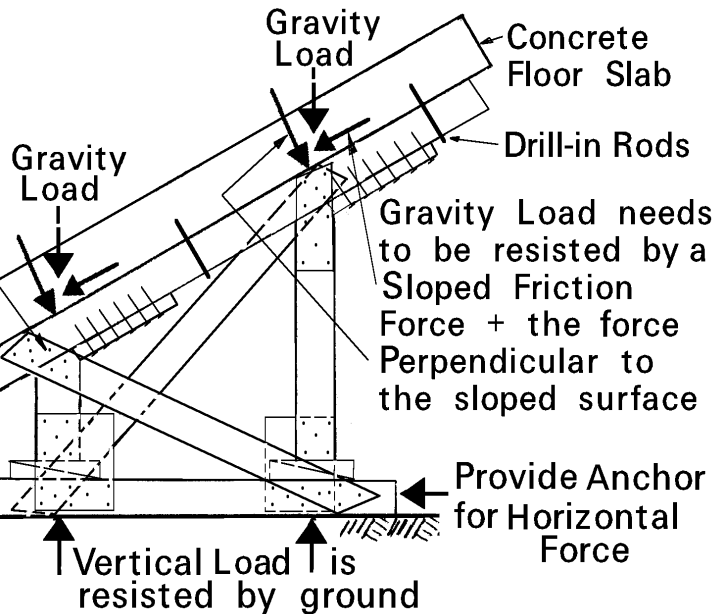

SLOPED FRICTION METHOD

At slopes over 5% need to enhance Friction by making some type of Connection between Header and Sloped Floor

MODULE 2a SHORING BASICS

VERTICAL SHORES ON SLOPED SURFACE – EARTH AND PAVEMENT

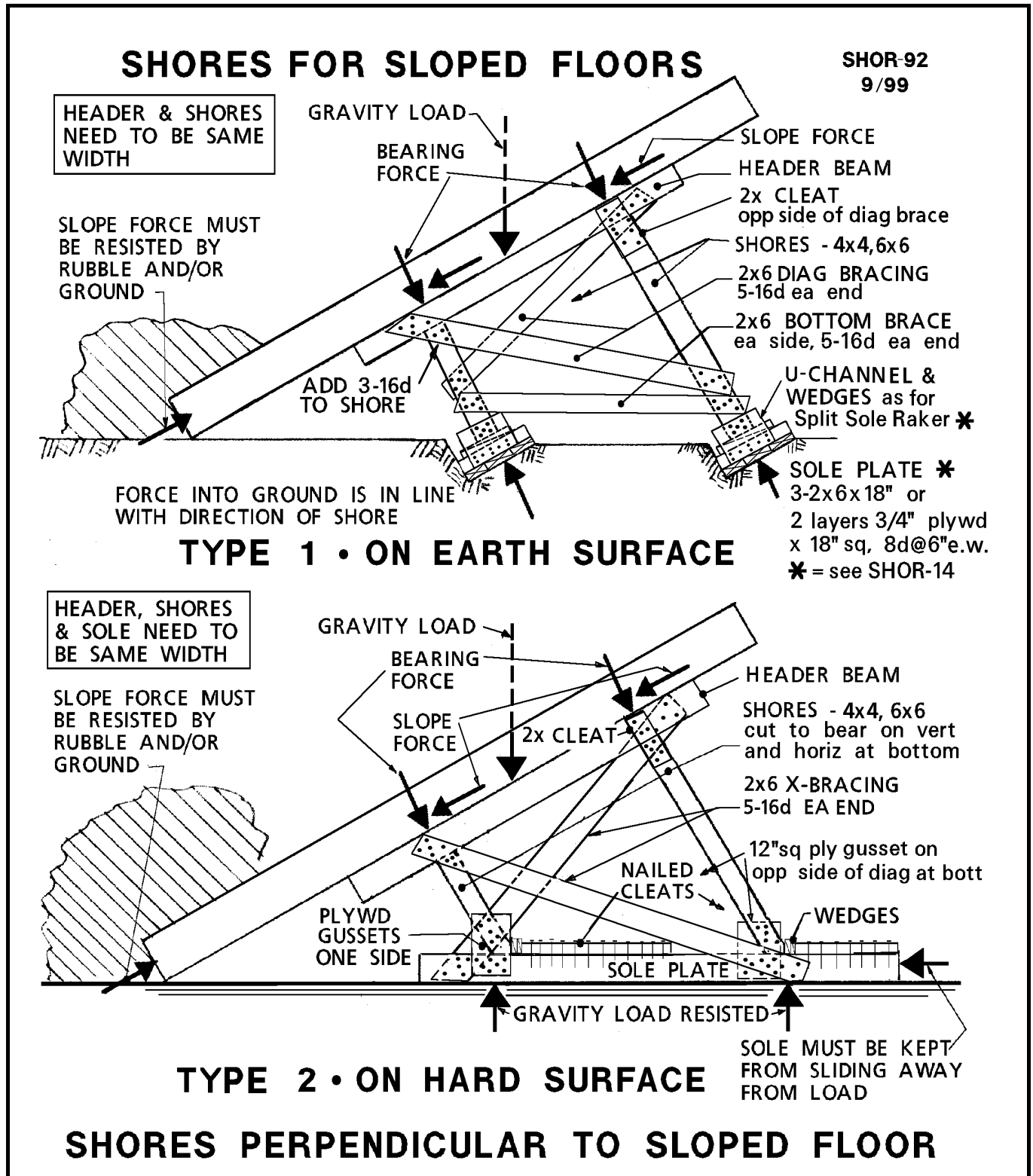

MODULE 2a SHORING BASICS

VERTICAL SHORES ON SLOPED SURFACES (continued)

- All sloped floor shores should be built as systems
 - Construct systems as a minimum of two, two post shores, spaced from 4 to 8 feet on center.
 - Diagonal bracing (**X** bracing) should be placed in the plane of the shore (as shown in SHOR-92)
 - Diag bracing should be designed for 10% min , weight of supported structure
 - Bracing between shores should be configured as lacing (Laced Post Shores) if shores are kept within 5 ft o.c.
 - However if shores are spaced more than 5 ft but less than 8 ft o.c., they should be laterally braced using horizontal and **X** or **V** bracing as for Raker Shores (see Shor 14 & 17)
 - When the height of to shorter end of the shore gets as small as three feet, a 16 inch wide strip of ¾" plywood should be used between shores instead of X bracing.
 - Nail plywood with 8d @ 3" o.c. staggered each end
 - 6x6 shore posts should be used where heavier, concrete floor systems are encountered
- For conditions where the shore height is less than 3 feet, Cribbing can be used to support sloped floors, SHOR-10r
 - Slope for crib supported floor should not exceed 15%.
 - Cribs can be built into the slope, but care must be taken to properly shim the layers in order to maintain firm, complete bearings.
 - Notched crib members could be used since they can transfer more lateral load than the usual friction interconnection.
- Well braced systems using normal Vertical Shores (SHOR-1) may be used when floors are sloped less than 5%
 - Again use the shores in pairs with either lacing or horizontal plus **X** or **V** bracing in between shores as for Rakers.
- **Summary for Sloped Floor Shores**
 - As stated in adjacent slide, Sloped Floor Shores are complicated, not simple. No one or two solutions will work for all conditions
 - One needs to carefully assess the situation, to determine which way the floor will move.
 - To shore sloped wood floors the header needs to be placed perpendicular to the joist
 - Very adequate bracing is required in an attempt to better resist the forces that may not be accurately predicted

LATERAL BRACING FOR SLOPED FLOOR SHORES

- Use pairs of shores, spaced 5' max. o.c. with bracing between as in Laced Posts
or
- Use 2 or more shores, spaced up to 8 ft o.c. with longitudinal and X and V bracing as in Raker Shores.
- This is to be discussed later here and in Module 2b

SLOPE FLOOR LACING

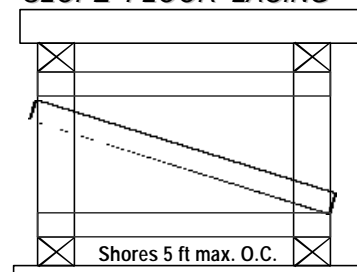

SLOPE FLOOR BRACE (when too short for lacing)

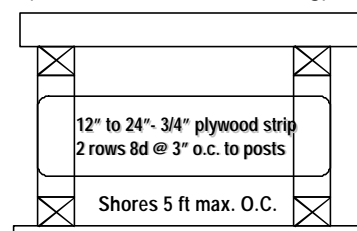

SLOPE FLOOR X BRACING

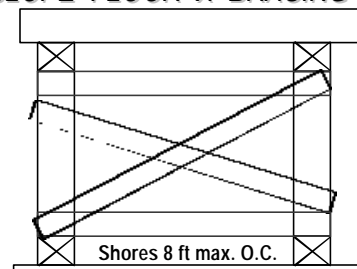

SUMMARY FOR SLOPED FLOOR SHORES

- No simple, "one fits all conditions answer".
- Shore needs to resist the load in direction it's tending to move
- Perpendicular Bearing Method may work most of the time for concrete floors, since they usually remain connected to structure.
- Sloped Friction Method needs connection between header & floor to be reliable
- Wood floors need header perpendicular to joist.

MODULE 2a SHORING BASICS

VERTICAL SHORES ON SLOPED SURFACE – CRIBBING

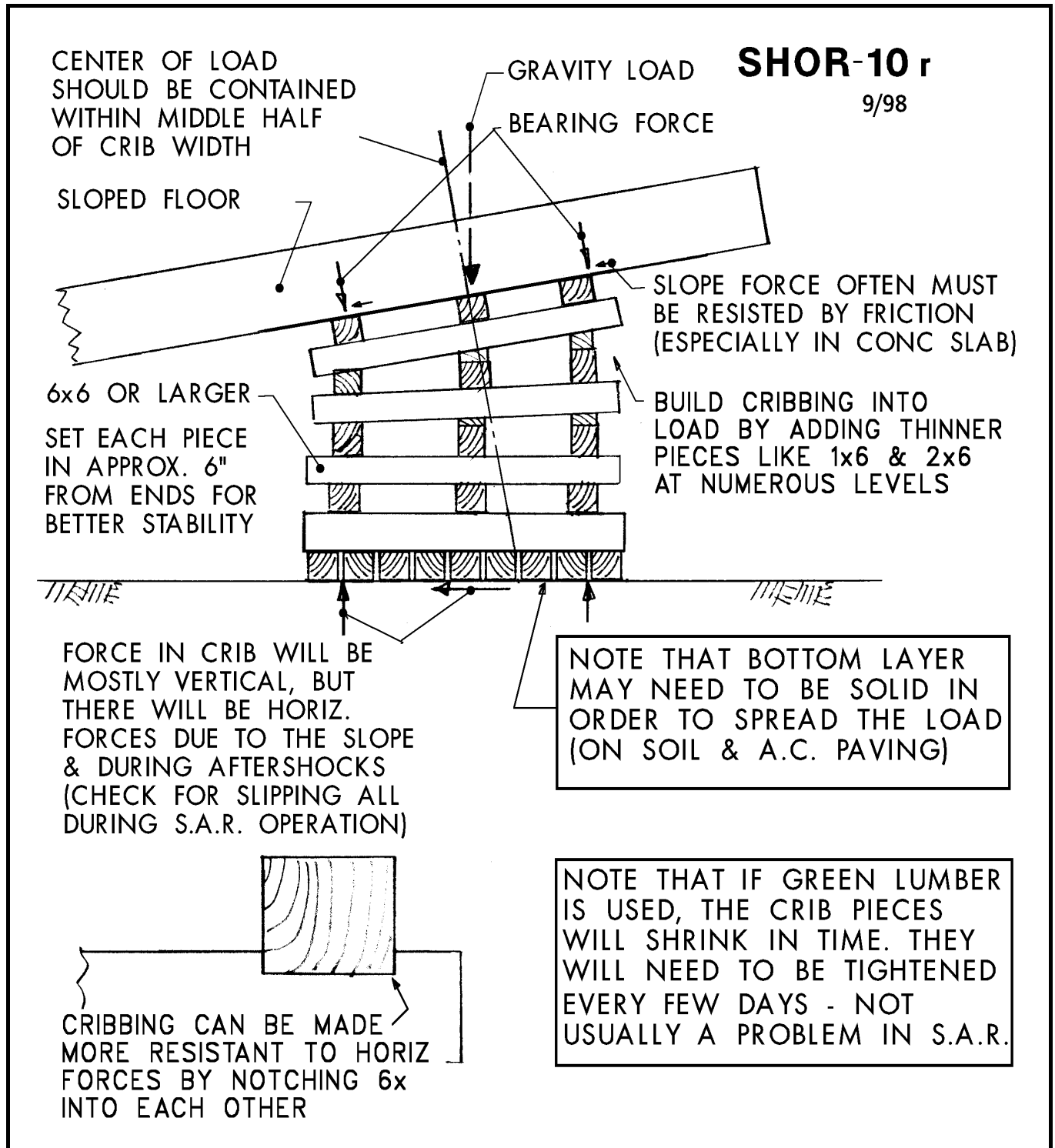

MODULE 2a SHORING BASICS

LATERAL SHORING SYSTEMS

We will now discuss the Lateral Shoring Systems shown in the adjacent slide:

- **Principles of trench shoring** may sometimes need to be applied to US&R, where pulverized masonry rubble tend to cave into an otherwise accessible space.
 - As previously discussed, Pneumatic Shores may be used in vertical applications since they have positive locking devices
- There are several systems used as Lateral Shores, such as
 - Wood Horizontal Shores
 - Hydraulic Shores,
 - Pneumatic Shores,
 - Tieback Systems
 - Drilled-in Solid or Pole Systems.

The design of these systems is very competently presented in the CALTRANS, Trenching and Shoring Manual.

WOOD HORIZONTAL SHORES

- These wood shores have been used by Firefighters in URM and other damaged buildings to support bulging walls.
- Since the horizontal wood posts (struts) are usually short their capacity is normally based on cross grain bearing strength (300 to 700psi)
- Wall plates are used to spread the load from 2 or more posts.
 - Wedged are used to tighten the horizontal struts.
 - Bracing and cleats are added to complete each shore. (box in wedges and interconnect all members)
 - The normal **X** braces may need to be eliminated to allow for access, and in that case corner, plywood gussets are added to help connect corners and brace the shore
- The shores are normally spaced at 8 feet on center, depending on the situation.

LATERAL SHORING SYSTEMS

- HORIZONTAL SHORES
- TRENCH SHORES
- RAKER SHORES
- TIEBACKS

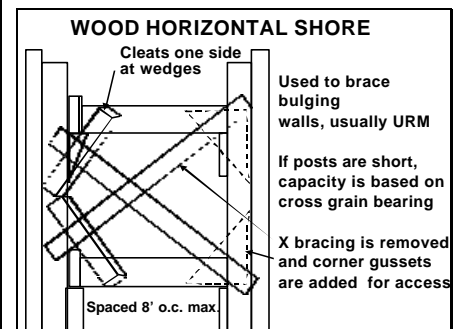

MODULE 2a SHORING BASICS

HYDRAULIC TRENCH SHORE

- These are frames made from aluminum hydraulic ram(s) with continuous side rails
- They are intended to be dropped into open trenches from the top and pressurized with a 5 gallon hand pump to between 500 - 1000 PSI.
 - Plywood panels are added against the soil to spread the load and confine soils.
 - There is no locking device as for pneumatic shores, therefore **hydraulic shores are not recommended** for supporting vertical loads.
- Hydraulic Shores can have a single ram with 2 feet long rails or double rams with rails up to 12ft long. Standard double ram frames have rails in 3.5ft, 5ft and 7ft lengths

OTHER TRENCH SHORES

- Trench Jack (Screw Jack)
- Post Screw Jack
- Pneumatic Shore
- All have same capabilities as in vertical application.

LATERAL SHORING SYSTEMS (continued)

ONE-SIDED TRENCH SHORE

- This type of shoring is needed when one side of a trench has caved in.
- These systems have been successfully used to temporarily raise river levees.
- They must be designed for specific condition of type of load (soil, water) and type of supporting soil.

HYDRAULIC TRENCH SHORES

- Aluminum hydraulic rams w/side rails
- Pressurized w/5 gal hand pump to 500 - 1000 psi
- Installed w/special plywood sheathing
- Spacing depends on type soil, depth & width
- Must maintain pressure to carry load - no lock

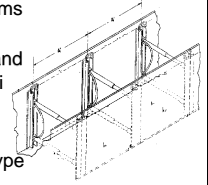

OTHER TRENCH SHORES

- Trench Jack - same capacity as vertical
- Post Screw Jack - same as vertical
- Pneumatic Shores - same as vertical (intended as trench shores and are first set w/ air pressure and then nut or pin is set for positive connection)
- **USE MFR'S PIN END VALUES**

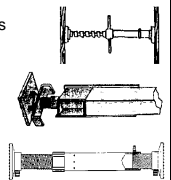

ONE SIDE TRENCH SHORE

- Type of shoring needed w/ one side trench caved in
- Has been used to raise river levees
- Must be designed for conditions of load & supporting soil

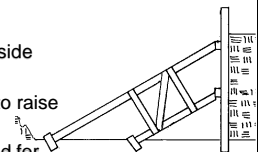

MODULE 2a SHORING BASICS

RAKER SHORES

- Useful in bracing URM and other heavy walls that have cracked, (especially at corners) and/or are leaning away from building.
- Need to be configured in system that will account for both vertical and horizontal components of force in diagonal member
- The vertical component may be resisted by:
 - Friction, which may be increased in a full triangular configuration, by applying more horizontal load at the base, against the wall. However, friction should not be considered as reliable, especially during aftershocks.
 - By placing drilled-in anchors thru the wall plate into the masonry. (This may be too dangerous in some areas of badly cracked walls)
 - By bearing the wall plate against a projection in the wall surface, or by placing the raker at an opening and nailing a cleat onto the plate so that it will bear on the opening head.
- The required horizontal force may be less than two percent of the wall weight, since URM walls are seldom left standing very far out of plumb. However, since aftershocks are likely to occur, raker systems should be designed for about 10 percent of the weight of the wall and roof that is within the tributary area that they support.
- Raker shores should be placed from 8 ft. on center, depending on wall type and condition. They should be designed by engineers that have experience with these systems.
- Rakers should be built away from dangerous area next to wall and then carried/walked into place
- Rakers may be configured using the Full Triangle method (called Fixed raker) or as a Flying Raker (Friction Raker)
- The capacity of Rakers is usually limited by the nailed cleat connections, and/or the connection to the ground.
 - Special U-channels are used to connect the shore to Earth for Flying and Split Sole Rakers as shown in adjacent slide.
 - In addition for Split Sole Rakers a square, spread footing is added under to U-channel to reduce to soil pressure

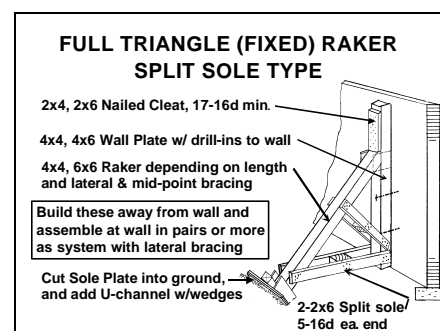
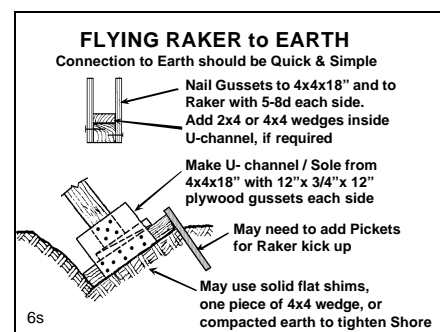
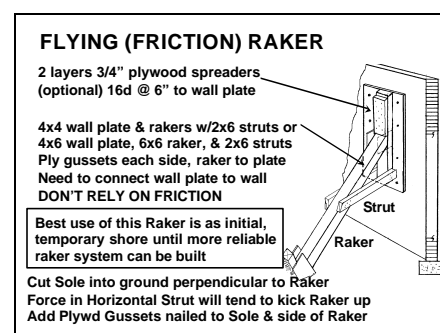
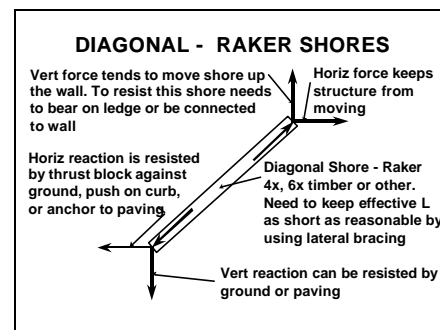

MODULE 2a SHORING BASICS

RAKER SHORE SYSTEMS

DIAGONAL (RAKER) SHORES

SHOR-12 9/99

VERTICAL FORCE TENDS TO CAUSE SHORE TO MOVE UP THE WALL. TO RESIST THIS, THE SHORE NEEDS TO BEAR ON A LEDGE OR BE CONNECTED TO WALL
*Don't rely on friction
 Think aftershocks
 and wind*

HORIZ. FORCE TENDS TO KEEP WALL AND/OR BUILDING FROM MOVING

DIAGONAL SHORE - MAY BE 4x OR 6x DEPENDING ON ITS LENGTH BETWEEN POINTS WHERE LATERAL BRACING IS PROVIDED *IN EACH DIRECTION*

4x should have mid point bracing if over 11ft long
 6x " " " " " " " " 16ft "

HORIZONTAL REACTION MAY BE RESISTED BY CUTTING THRUST BLOCK INTO GROUND, BY PUSHING AGAINST CONCRETE CURB, OR BY SOLE PLATE WITH CLEATS, WEDGES, & ANCHORS

VERTICAL REACTION NORMALLY CAN BE RESISTED BY GROUND, PAVING

FORCES IN RAKER SHORES

* = may need to use spreader at either type if wall is badly cracked

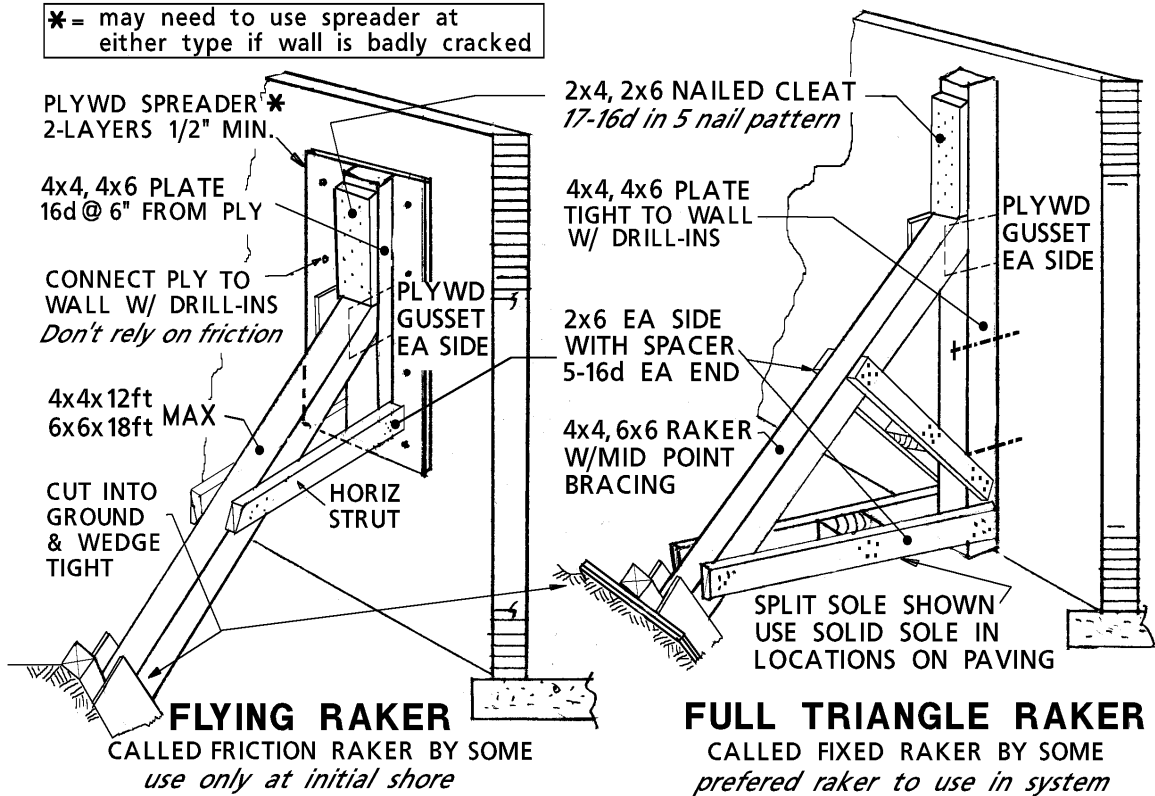

Except for initial temporary stabilization, raker shores should be built in systems of at least two with lateral bracing between them.

MODULE 2a SHORING BASICS

RAKER SHORES (continued)

- Either configuration (Full Triangle or Flying) could be used on walls up to about 24 ft. high. Six-inch wood members would be required when raker length exceeds 12 ft., unless midpoint lateral bracing is provided.
- It is difficult to obtain lumber over 20 ft. long, but splices may be made in rakers as long as they are located near where the diagonal and lateral braces connect. (SHOR-14) Use 2x4x3ft min each side of splice, nailed with 8-16d each side each end.
 - Also $\frac{3}{4}$ inch plywood may be used to splice the Raker. One should use 2 foot, min, long pieces each side, the same width as the raker.
 - Nail plywood splice plates with 8 – 8d each side each end.
- Flying Rakers take the least amount of material to build but have several disadvantages.
 - They are recommended for use to initially stabilize a wall and/or building until a system with more reliable bracing can be installed.
- Full Height Rakers will weigh more, use more material, but are easier to walk along the ground for installation and can be more adequately braced.
- Lateral bracing, consisting of continuous horizontal struts (capable of resisting compression and tension) and diagonal bracing (in either **V** or **X** configuration) should be installed in all raker systems.
- Full Height Rakers can be built into tall, multi-raker configurations using 4x4 members with lateral bracing to bring the L/D ratio to between 35 and 40. (SHOR-14)
- Multi-raker is fairly complicated, but show how the smaller timbers can be used in a system to stabilize a two-story wall. Note that the bracing needs to be placed in two mutually perpendicular directions.

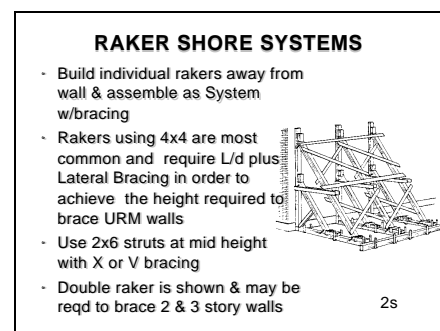
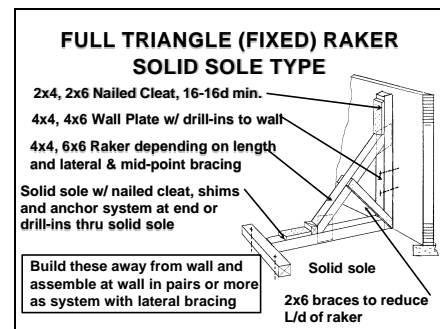
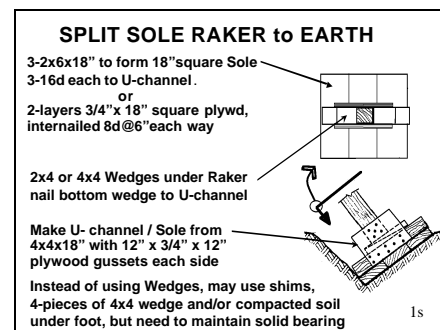
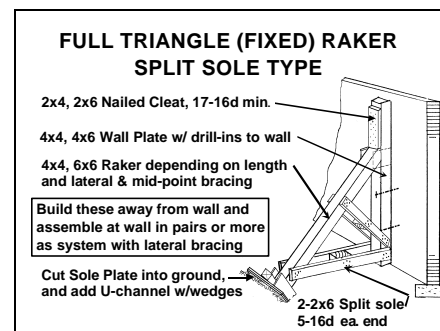

MODULE 2a SHORING BASICS

RAKER SHORE SYSTEMS

RAKER SHORE SYSTEMS

SHOR-14

4/99

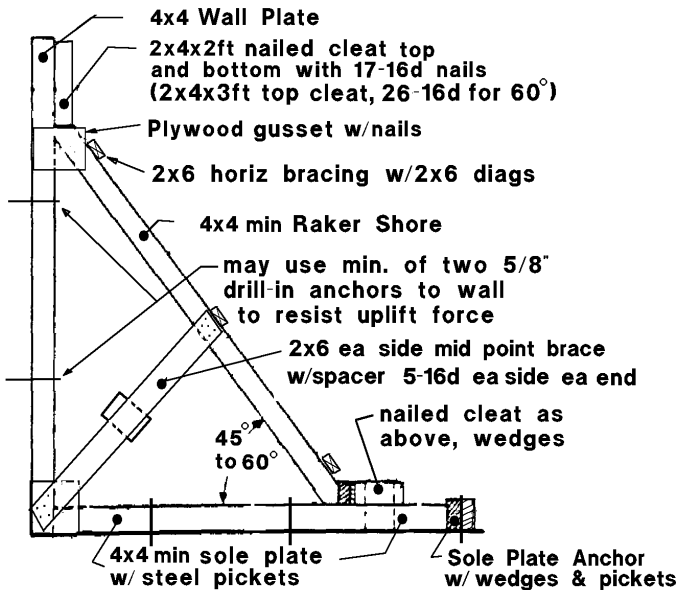

All systems using 4x4 members over 11ft long should be braced in two directions in order to limit L/D to 35 ±. Its better to have a 2x6 continuous at top, mid, & bottom w/ X-braces every forty ft or so than what is shown here.

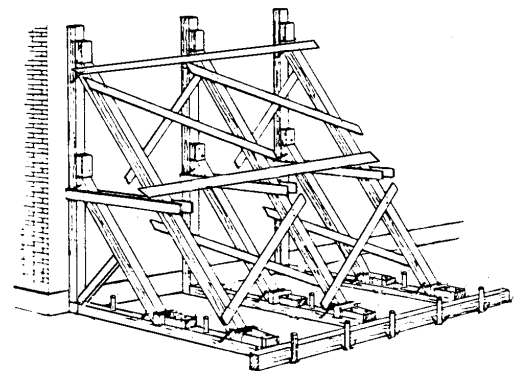

PREFERRED FULL TRIANGLE
 RAKER SHORE CONFIGURATION
 (SOLID SOLE FULL TRIANGLE RAKER)

RAKER SHORE FRAMES
 MUST BE BRACED

Double and triple configurations allow 4x4 members to be used in taller walls by providing bracing to reduce L/D to 35 or so

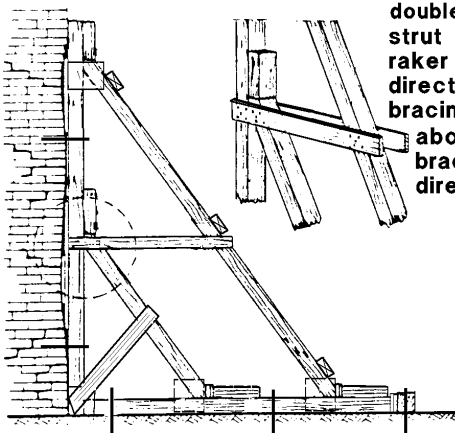

DOUBLE DIAGONAL

double 2x6 horiz. strut braces long raker in one direction. Lateral bracing shown above provides bracing in other direction

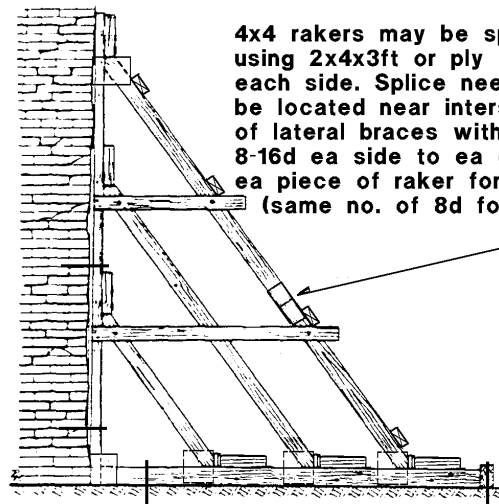

TRIPLE DIAGONAL
 not too practical

4x4 rakers may be spliced using 2x4x3ft or ply gussets each side. Splice needs to be located near intersection of lateral braces with raker. 8-16d ea side to ea end of ea piece of raker for 2x (same no. of 8d for ply)

MODULE 2a SHORING BASICS

RAKER SHORE CONNECTIONS

RAKER SHORE CONNECTIONS

SHOR - 15 9/99

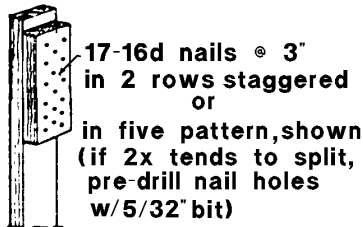

NAILED TOP

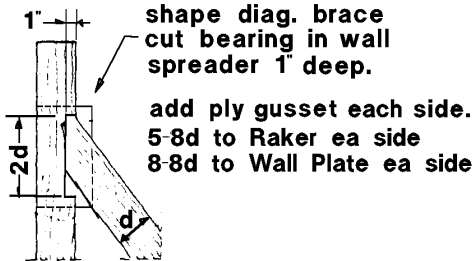

NOTCHED TOP

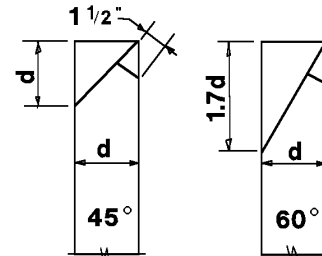

RAKER END CUT

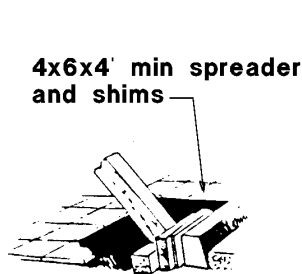

BOTTOM AT CURB

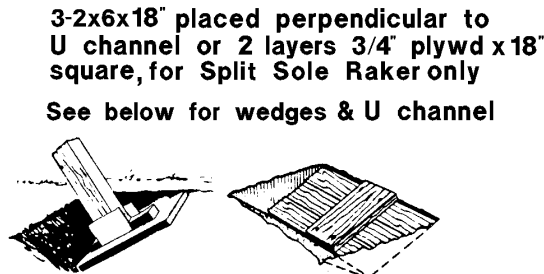

BOTTOM IN FIRM GROUND

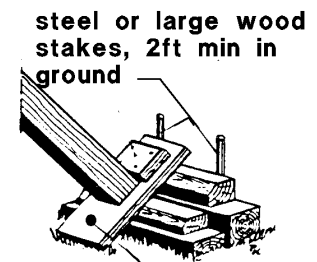

BOTTOM AT PAVING

(intended for use with flying raker or full triangle raker with split sole plate)

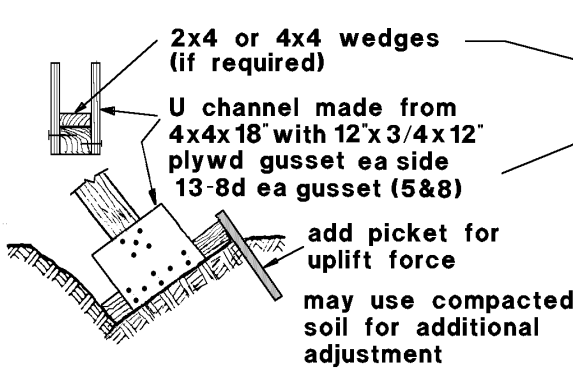

AT FLYING RAKER

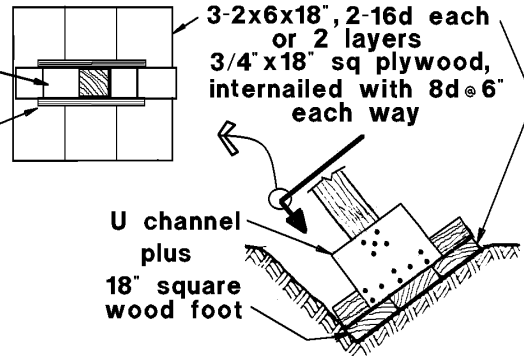

AT SPLIT SOLE RAKER

DETAILS AT BOTTOM

FABRICATION AND ERECTION

- ALL RAKERS SHOULD BE FABRICATED IN AN AREA AWAY FROM A DAMAGED MASONRY WALL, SINCE AFTERSHOCK COULD CAUSE COLLAPSE
- AFTER FABRICATION, THE RAKERS NEED TO BE CARRIED OR WALKED TO THE WALL, AND ADJUSTED FOR TIGHT FIT.

MODULE 2a SHORING BASICS

LATERAL SHORING SYSTEMS (continued)

RAKER ANGLE

The angle between the ground and a diagonal (Raker) brace member should be as small as practicable.

- When the angle is as small as 30 degrees, the horizontal force applied to the wall is 87% of the force in the diagonal, and the upward force that needs to be resisted at the wall face is only 50% of the diagonal force.
- When the angle increases to 60 degrees the horizontal is 50%, and the vertical is 87%.
- At 45 degrees the two are equal at 71% of diagonal force.
- The disaster "field" conditions such as need for access, available timber length, or clearance, may require that the less efficient 60-degree system is the only practical way to do the bracing.
- One must find the best compromise between structural efficiency and practical considerations. The simplest to deal with may be 45 degrees (1 to 1) and 60 degrees (1.7 to 1)
 - The 60 degree angle is preferred for the Split Sole Raker, since the soil has better resistance to a more vertical load.

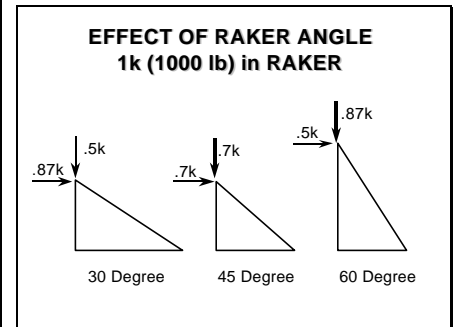

RAKER SHORE CONSTRUCTION

- The capacity of individual, single, full triangle Rakers is in the range of 2400 lbs. (2.4k). This is normally sufficient to brace most masonry or low rise concrete walls up to about 20 ft high.
 - This is the capacity based on the horizontal load of the wall. (the force in the sloped Raker member may be as much as twice the horizontal load)
 - The capacity of Flying Rakers is about 1000 lbs (1.0k)
- The full Triangle Rakers can be configured with a split sole plate (SHOR-17, next page), which is most useful for bearing on ground. This example shows how a 4 x 4 lumber x 20 ft. long can be used to brace a 20 ft. wall.
 - Lateral bracing is required at mid-height of the 4 x 4 in each direction.
 - Overall lateral bracing is required to stabilize the system of Rakers, especially during aftershocks.
- A second configuration of full Triangle Raker is shown with solid sole plate (SHOR-18, following next page). This is most useful where paving is found next to the wall. It has the same L/D and overall bracing requirements as the split sole type.

MODULE 2a SHORING BASICS

RAKER SHORE CONSTRUCTION (continued)

FULL HEIGHT RAKER • SPLIT SOLE TYPE SHOR-17

9/99

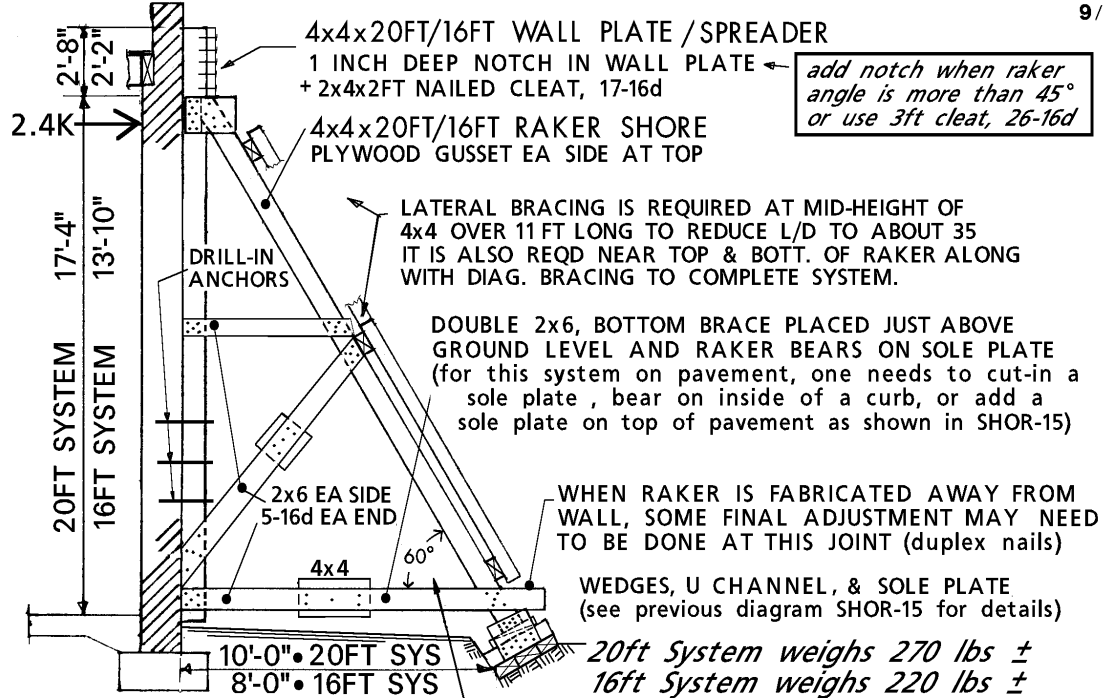

60° is shown to give max. height and min horiz. force into soil. This is preferred config. on soil due to it's weaker resistance to horiz. thrust

RAKER ELEVATION

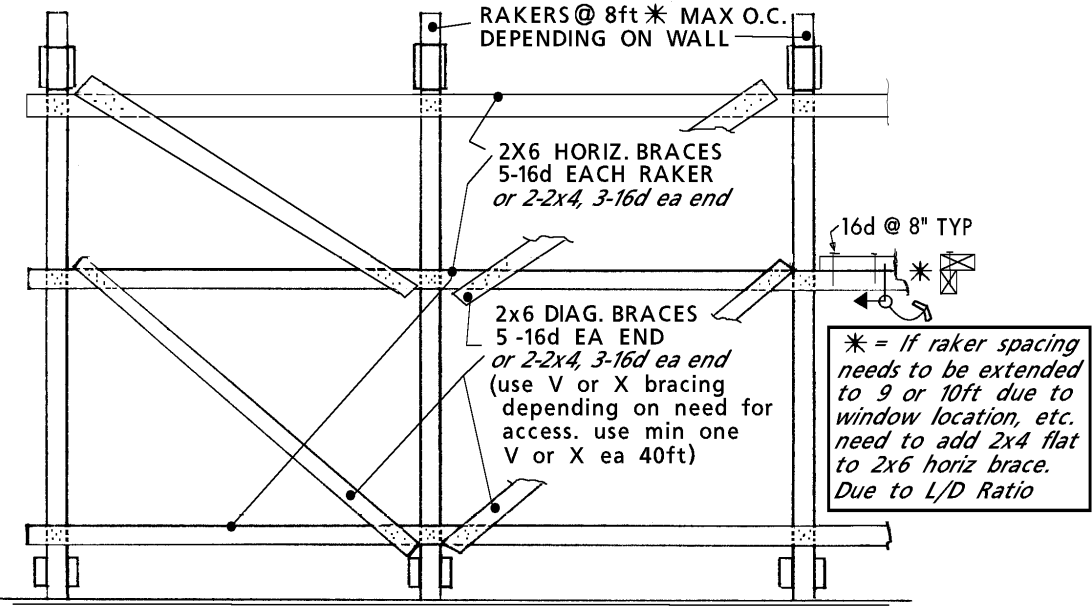

RAKER BRACING ELEVATION

MODULE 2a SHORING BASICS

RAKER SHORE CONSTRUCTION (continued)

FULL HEIGHT RAKER • SOLID SOLE TYPE SHOR-18

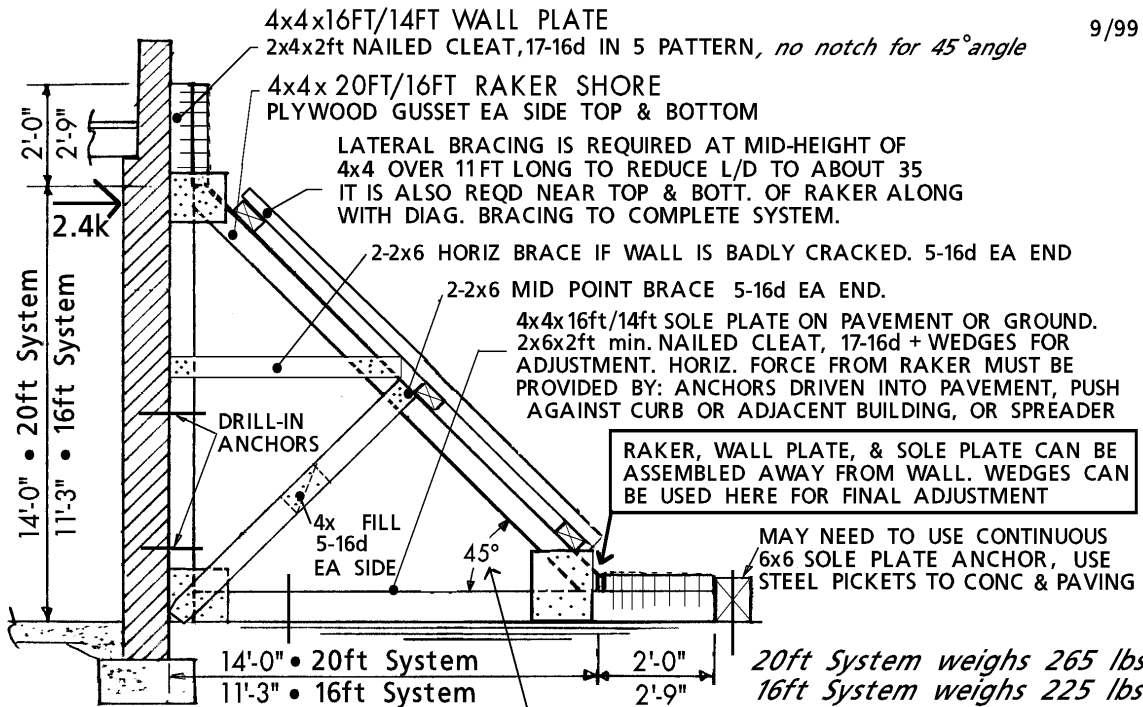

45° is shown as simplest sys for on paving. 60° config would be preferred on soil, since horiz thrust at ground is less and height reached on wall is greater.

RAKER ELEVATION

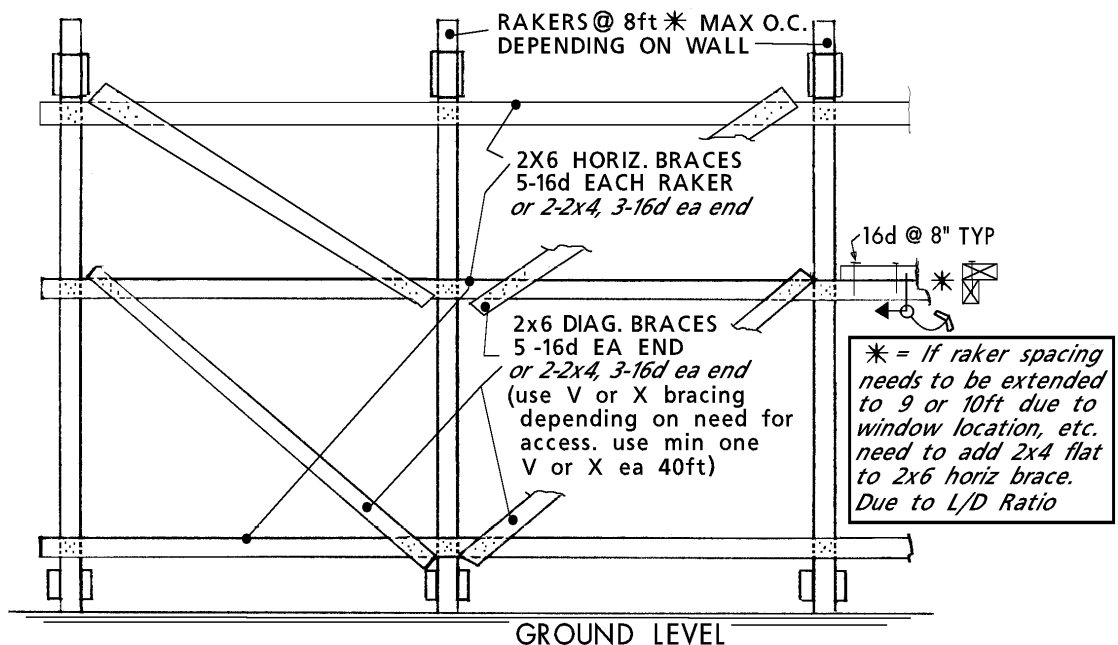

RAKER BRACING ELEVATION

MODULE 2a SHORING BASICS

LATERAL SHORING SYSTEMS (continued)

PNEUMATIC SHORES USED AS RAKERS

A quick, temporary raker can be constructed using pneumatic shores.

- They can be used as individual units, or be configured in a system of two or more that are interconnected with 2x6 wood bracing.
- Special rails and connections are available for the shore manufacturers, as well as base plate and bracing connections.

PNEUMATIC SHORES USED AS RAKERS

- Raker = 2 struts + special rail
- Has base plate + special conn.
- Anchor base plate to paving w/steel bars or drill-ins.
- Add steel angle under base plate to bear on typical anch pl
- Can be used in system w/ horiz. & diag. 2x6 bracing
- Need to pin rail to wall.
- Best used as initial shore to be followed by wood system

2s

TILT-UP WALL BRACES

- Can be used to brace concrete tilt-up walls and other reinforced masonry walls. They are available for rent from Concrete Supply Firms such as Burke Co.
- The walls would need to be pretty well intact and only in need of bracing, due to connection failure. (spreading of the load would induce bending moments in the wall).
- Connection of braces to the wall could be by drill-in anchors and anchorage at the base could be to a wood curb/pad or slab on grade with a drill-in.
- These braces could also act in tension.

TILT-UP WALL BRACING

- Can be used to brace reinforced concrete or masonry wall
- Use Drill-in Anchors for connections to wall & floor slab.
- Can act in Tension or Compression

1s

TIEBACKS

- When URM walls are over thirty feet tall it is probably impractical to attempt to brace them with raker shores.
- Vertical and/or horizontal strongbacks could be placed on the face of a hazardous wall and tied across the structure to a floor beam or the opposite side wall. (see Shor-16a on next page)
- The strongbacks could be made from double 2x6 wood members with the tie being placed between them. Solid 4x or 6x members could also be used.
- The ties that have been placed by contractors were steel rods with turnbuckles, bearing washers etc. Cables with come-along could also be used as well as utility rope, chain, etc. One may need to be creative to obtain an adequate tie, but climbing rope, used by firefighters should be considered only as a last resort. (Climbing rope is considered unreliable with the rough treatment of this type of application and would be discarded)

TIEBACK SYSTEMS

- Used to keep wall from falling when too high for Rakers
- Strongbacks - 4x4, 4x6, 2-2x6
- Strongbacks go floor to floor
- Tiebacks - rope, cable, chain
- Extend tiebacks across bldg or tie to floor bms or columns

3s

MODULE 2a SHORING BASICS

LATERAL SHORING SYSTEMS (continued)

PNEUMATIC STRUTS USED AS RAKERS

- INDIVIDUAL RAKERS CAN BE CONFIGURED FROM TWO STRUTS (UP TO 16FT LONG) AND A SPECIAL RAIL THAT HAS CONNECTION HOLES
- MANUFACTURED BASE PLATE CAN BE CONNECTED TO PAVING THRU EXISTING HOLES USING STEEL BARS/DRILL-INS. STEEL ANGLE CAN BE ADDED UNDER BASE PLATE TO PROVIDE SURFACE TO BEAR ON TYPICAL WOOD SOLE PLATE ANCHOR
- THESE CAN BE MADE INTO SYSTEM USING TWO OR MORE INDIVIDUALS, INTERCONNECTED WITH HORIZONTAL + DIAGONAL 2x6 WOOD BRACING CONNECTED TO MANUFACTURED CLIPS (THAT HAVE WOOD NAILERS)
- RAKER RAILS NEED TO BE PINNED TO WALL AS W/TYP RAKERS. THESE CAN PROVIDE A QUICKLY PLACED, INITIAL SYSTEM TO BE FOLLOWED W/TYP WOOD SYSTEM

SHOR-16a
9/98

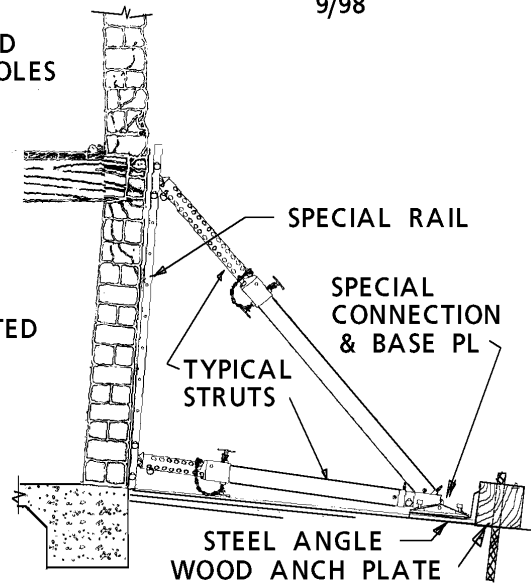

WALL TIEBACKS

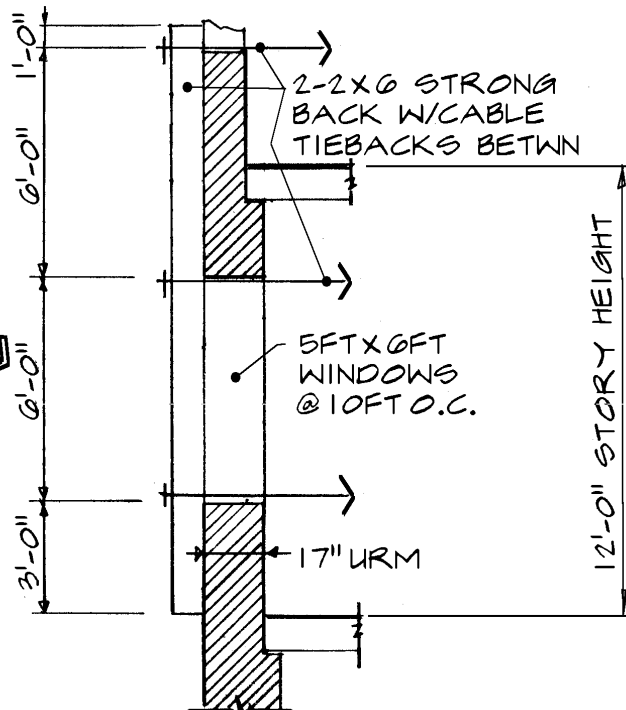
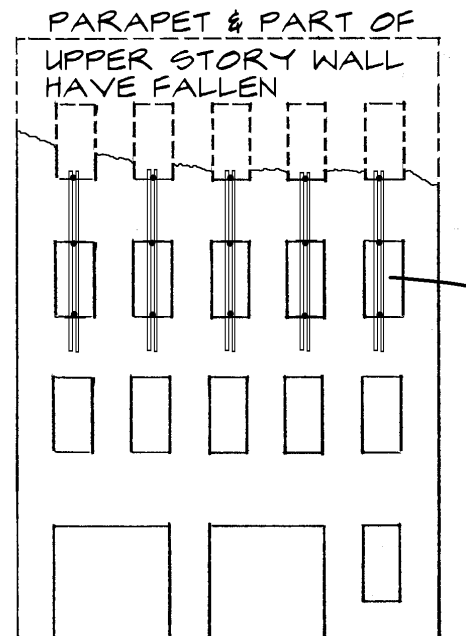

4 STORY U.R.M. OFFICE BUILDING TYPICAL WINDOW SECTION

- THE STRONG-BACKS COULD BE MADE FROM 4x4, 4x6, OR 2-2x6.
- THE STRONG-BACKS SHOULD EXTEND FROM FLOOR TO FLOOR IN ORDER TO HAVE THE FLOOR PLANES TO PULL AGAINST.

MODULE 2a SHORING BASICS

SHORING SYSTEMS USED IN US&R

The Special Medical Response Team, a group of medical first responders organized to aid mine collapse victims, has a plan to use a combination of pneumatic shores and cribbing to assure vertical support in order to provide medical care within the collapse. They first set the pneumatic shores and then follow with the cribbing.

STABILIZE WOOD APARTMENT

The House Moving Contractor, R. Trost, provided emergency shoring after the 1989 Loma Prieta Quake for twenty-five buildings in the San Francisco Marina District. The 3 & 4 story wood buildings were out of plumb in the first story as much as 2 feet. As shown in SHOR-21 & 22, they provided lateral stability by placing 6x8 diagonal shores from the inside of the street curb to the second floor, and added 6x6 diagonals in doorways. They later placed story high cribbing and large steel beams to provide better vertical support, and allow for later straightening of the buildings.

- One must carefully consider where this type of bracing is connected to the structure in order for it to effectively obtain a vertical reaction while it is providing the horizontal resistance

STABILIZE TALL HIGHWAY STRUCTURES

At the Highway 880 collapse, Loma Prieta Earthquake, shoring contractors used 12x12 vertical posts to support the concrete frames in the first story that were damaged by the collapse of the second story. The 20 ft. height was too great for cribbing, and a spreader system was used to interconnect the posts at the ground level. Diagonal bracing was added to same locations of those rows of posts, but it was very light for the potential load.

USE OF NON-TRADITIONAL SHORING DEVICES

Large back-hoe/excavator or bucket-loader vehicles have been used to provide lateral (raker) support to leaning walls and buildings at several disaster sites. Very good idea for an emergency condition.

SYSTEMS USED IN US&R

- SMRT, group of Dr & EMT responders to Mine Collapse use Pneumatic as initial shores to build Cribbing
- SF House mover, R Trost shored 25 wood apartments after 1989 E.Q. that were out of plumb up to 2 ft. He used 6x8 diagonal from front curb & 6x6 diag in garage doorways.

STABILIZE WOOD APARTMENT

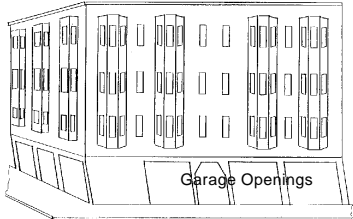

Garage Openings

San Francisco 1989 - 36 bldgs as much as 24" out of plumb in 1st story - stabilize or demolish 2s

STABILIZE WOOD APARTMENT

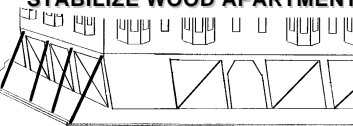

- Diag 6x8x20 ft shores placed from cut in sidewalk behind curb up to 2nd floor to align with floor beams.
- Door jambs were removed and diag. 6x6 were added in garage openings. 5s

MODULE 2a SHORING BASICS

SHORING FOR SPECIFIC BUILDING TYPES

SHORING FOR LIGHT FRAME, MULTI-STORY BUILDINGS

- Multi-story frame with leaning first story need lateral/diagonal shoring that acts against the floor plane
- Wood building with crawl space that have moved off foundation have normally come to rest, but roof and upper story floors may also be offset/cracked and need vertical shoring
- Brick veneer on wood frame walls often are falling hazards in aftershocks, and may need to be shored or protective tunneling type structure may be required to protect access.

SHORING FOR URM BUILDINGS (HEAVY WALL)

- URM walls may be cracked (especially at corners) or peeled and need diagonal/raker shores.
- Cracked URM walls may also require shoring of openings.
- When URM exterior walls have collapsed, the remaining wood floors may require vertical shoring.
- Floors often collapse into the following patterns: (see Shor-23s on next page)
 - **LEAN-TO** - shoring is usually required under the suspended floor and possibly on the outside wall, opposite where the floor is still connected. Victims might be found under the suspended floor and on top of this floor at the lowest end
 - **V-SHAPE** - shoring is usually required under the two suspended floor pieces and possibly on the outside walls, opposite where the floors are still connected. Victims might be found under the two suspended floor pieces and on top of the floor in the middle of the V.
 - **PANCAKE** - shoring is usually required under the floors. Victims might be found under the floors. Voids are formed by building contents and debris wedged between floors
 - **CANTILEVER** - this type is similar to the pancake pattern with the added problem of some of the floor planes extending, unsupported from the debris pile. Shoring is usually required under and above the floors starting at the lowest level. Victims might be found under the floors as in the pancake condition.

FIRST THOUGHTS ON SHORING VARIOUS TYPES OF BUILDINGS

Pages 32 thru 34 contain suggestions regarding the following types of buildings:

- Light Frame
- URM - Heavy Wall
- TU - Heavy Wall
- C1 - Concrete Frame Heavy Floor
- PC2 - Precast Concrete

MODULE 2a SHORING BASICS

SHORING FOR SPECIFIC BUILDING TYPES (continued)

URM WALL / WOOD FLOOR COLLAPSE PATTERNS
SHOWING POSSIBLE SHORING LOCATIONS SHOR-23s 9/98

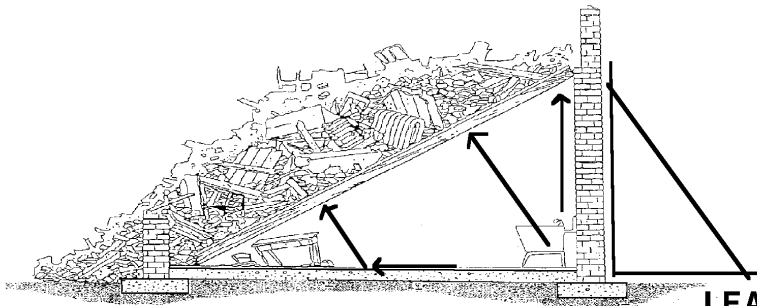

LEAN-TO FLOOR COLLAPSE

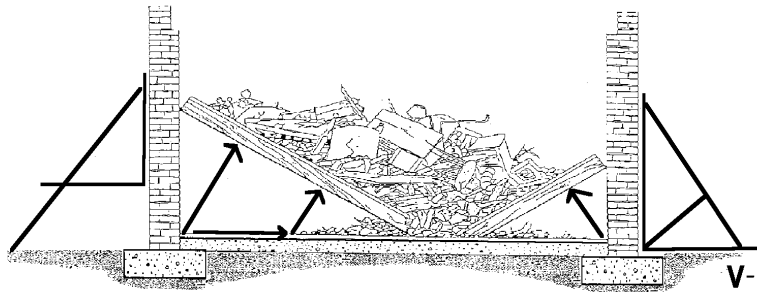

V-SHAPE FLOOR COLLAPSE

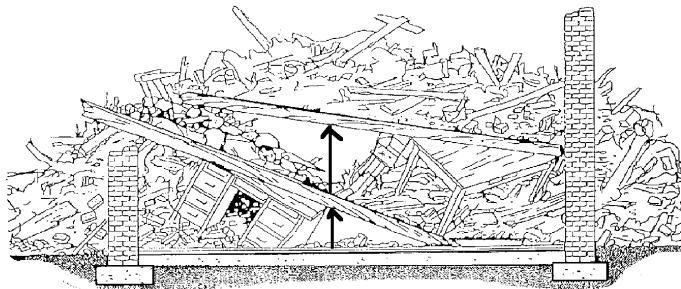

PANCAKE FLOOR COLLAPSE

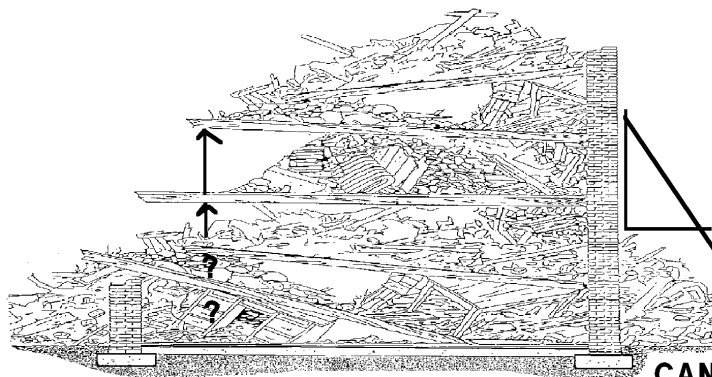

CANTILEVER FLOOR COLLAPSE
(pancake with extended floor)

MODULE 2a SHORING BASICS

SHORING FOR SPECIFIC BUILDING TYPES (continued)

SHORING FOR REINFORCED CONCRETE BUILDINGS

- Will often have fairly unbroken planes that can be easily shored w/ vertical shores.
- When floors have beams & girders intersecting at the columns, diagonal tension, shear cracks will give indication of potential failure.
- In flat slab (beamless) floors that are heavily loaded with debris, a punching shear (rapid) failure is possible. Since the cracking that indicates this type of overload usually is best seen from the top of the slab (covered by debris), it is very difficult to assess.
- If concrete floor plane is badly broken, a system with sheathing, spreaders, and safe haven areas may be needed.
- Lean-to, V-shape, and Pancake collapse patterns may be found in heavy floor buildings. (especially pancake)
- In floors where post-tensioned, cable reinforcing is present, a double hazard may be present. If the cables are loose, then the collapse will contain a mass of closely spaced, unreinforced pieces that are difficult to shore. If the cables are still tensioned, then they can become lethal missiles.

SHORING FOR PRECAST CONCRETE STRUCTURES

- Collapses of this type will normally contain large pieces of lightweight concrete. Shapes like single and double tees are difficult to shore.
- Lean-to, V-shape, and Pancake collapse patterns may be found in precast concrete buildings. (especially lean-to)
- Shoring of sloped surfaces will probably be required. Large pieces may be lightly interconnected and there will be the potential of their shifting.
- Using cranes to remove critical pieces may be the best strategy to access voids

MODULE 2a SHORING BASICS

SUMMARY FOR EMERGENCY SHORING OF STRUCTURES

- Shores need to be strong, light, portable, adjustable, and reliably support the structure as gently as possible.
- Systems should be used that are positively interconnected, laterally braced, and have slow, predictable failure mode.
 - A typical shoring scenario would begin with the placement of Spot Shores to initially stabilize, followed by
 - Individual multi post shore systems with in-plane bracing, followed by
 - Pairs (or greater numbers) of multi post shores that are X braced together as two-dimensional systems.
- Braced Wood Post Systems and Cribbing are desirable since they can be constructed to have the following properties:
 - Made from light pieces that are adjustable & can be built into most any conceivable situation including sloped surfaces
 - Relatively wide and stable. Will spread the load.
 - Can be proportioned to have slow failure mode that will give warning
- Systems need to be tested in order to determine best methods to resist:
 - Loads on sloped surfaces above and below
 - Loads during large aftershocks

In a disaster we need to consider any viable system based on availability of material, special contractors, and special equipment. The basic principles of engineering will always apply, but creative thinking and co-operation between all members of the Task Force is essential.

SUMMARY FOR US&R SHORING

- Shores - strong, light, portable
- Support as gently as possible
- Systems - positive connections & bracing
- Need slow, predictable failure mode.
- Testing would be helpful
 - Loads on sloped surfaces
 - Better way than friction transfer of lateral forces for cribbing.
 - What type of screws have NON Brittle failure