

**AUSTRALIAN EMERGENCY  
MANUALS SERIES**

**PART IV  
Skills for Emergency Services Personnel**

**Manual 40**

**VERTICAL RESCUE**

**Second Edition**

**EMERGENCY MANAGEMENT AUSTRALIA**

© Commonwealth of Australia 2001  
First published 1995  
Second edition 2001

ISBN 0 642 47685 3

Edited and published by Emergency Management Australia

Typeset by Defence Publishing Service, Department of Defence

Printed in Australia by Robey Integrated Digital Prepress, Printing and Distribution



**Australian Government**  

---

**Attorney-General's Department**  
**Emergency Management Australia**

**Copyright**

Permission to use the document and related graphics is granted provided that (1) the below copyright notice appears in all copies and that both the copyright notice and this permission notice appear, and (2) use of document and related graphics is for educational, informational and non-commercial or personal use only.

In all cases the Commonwealth of Australia must be acknowledged as the source when reproducing or quoting any part of this publication. Examples and quotations from other sources have been attributed to the original publication whenever possible and are believed to fall within fair use provisions, but these portions retain their copyright protection and must not be used without attribution.

Enquiries related to copyright should be addressed to:

The Director General  
Emergency Management Australia  
P0 BOX 1020  
Dickson ACT 2602

Or telephone (02) 6256 4600 or fax (02) 6256 4653 or email [ema@ema.gov.au](mailto:ema@ema.gov.au)

Any rights not expressly granted herein are reserved.

**Disclaimer**

This publication is presented by Emergency Management Australia for the purpose of disseminating emergency management information free of charge to individuals who provide professional training and supervision to members of professional organisations in the field of emergency management. Professional organisations include but are not limited to, professional fire fighters, trained emergency services volunteers, and members of State/Territory police and rescue organisations whose members have training and basic competencies in emergency management services.

The information in this publication is not intended to be used by the general public or untrained persons, and is not a substitute for professional advice and /or training. Untrained persons should not use this publication unless a trained and qualified emergency management professional supervises them and/or their training in the subjects listed in the publication.

Emergency Management Australia in consultation with emergency management professionals and subject matter experts exercises care in the compilation and drafting of this publication, however, the document and related graphics could include technical inaccuracies or typographical errors and the information provided may not be appropriate to all situations. In no event shall the Commonwealth of Australia (acting through Emergency Management Australia) be liable for any damages whatsoever, whether in an action of contract, negligence or other tortious action, arising out of or in connection with the sue of or reliance on any of the information presented in this publication.

Emergency Management Australia periodically updates the information in this publication. Before using this publication please check with the Training Officer in the State Emergency Services organisation in your State/Territory to ensure that this edition is the most recent and updated version of the publication."

# INFORMATION ON THE AUSTRALIAN EMERGENCY MANUALS SERIES

The first publication in the original AEM Series of mainly skills reference manuals was produced in 1989. In August 1996, on advice from the National Emergency Management Principles and Practice Advisory Group, EMA agreed to expand the AEM Series to include a more comprehensive range of emergency management principles and practice reference publications. The Series is now structured in five parts as set out below.

Parts I to III are issued as bound booklets to State and Territory emergency management organisations and appropriate government departments for further dissemination to approved users including local government. Parts IV and V (skills and training management topics) are issued in loose-leaf (amendable) form to all relevant State agencies through each State and Territory Emergency Service who maintain State distribution/amendment registers. All private and commercial enquiries are referred to EMA as noted at the end of the Foreword on page vii.

## AUSTRALIAN EMERGENCY MANUALS SERIES STRUCTURE AND CONTENT

Publishing  
Status—Jun 2001

### PART I—THE FUNDAMENTALS

Manual 1	Emergency Management Concepts and Principles (2nd/3rd edn)	A/R
Manual 2	Australian Emergency Management Arrangements (6th edn)	A
Manual 3	Australian Emergency Management Glossary	A
Manual 4	Emergency Management Terms Thesaurus	A

### PART II—APPROACHES TO EMERGENCY MANAGEMENT

#### *Volume 1—Risk Management*

Manual 1	Emergency Risk Management—Applications Guide	A
----------	--	---

#### *Volume 2—Mitigation Planning*

	Titles to be advised (covering PPRR)	P
--	--------------------------------------	---

#### *Volume 3—Implementation of Emergency Management Plans*

	Titles to be advised	P
--	----------------------	---

### PART III—EMERGENCY MANAGEMENT PRACTICE

#### *Volume 1—Service Provision*

Manual 1	Emergency Catering	A
Manual 2	Disaster Medicine (2nd edn)	A
Manual 3	Disaster Recovery	A/R

#### *Volume 2—Specific Issues*

Manual 1	Evacuation Planning	A
Manual 2	Safe and Healthy Mass Gatherings	A
Manual 3	Health Aspects of Chemical, Biological and Radiological Hazards	A
Manual	Civil Defence	D
Manual	Community Emergency Planning (2nd/3rd edn)	A/R
Manual	Urban Search and Rescue (Management)	D
Manual	Lifelines	D
Manual	Post-Disaster Assessment and Survey	D

## AUSTRALIAN EMERGENCY MANUALS SERIES STRUCTURE AND CONTENT

Publishing  
Status—Jun 2001

### *Volume 3—Guidelines*

Guide 1	Multi-Agency Incident Management	A
Guide 2	Community and Personal Support Services	A
Guide 3	Managing the Floodplain	A
Guide 4	Flood Preparedness	A
Guide 5	Flood Warning	A
Guide 6	Flood Response	A
Guide 7	Gathering Community Information	D
Guide	Psychological Services	D
Guide	Community Development	D
Guide	Managing Landslips	D
Guide	Managing Dambreaks	D
Guide	Disaster Victim Identification	U/R

### **PART IV —SKILLS FOR EMERGENCY SERVICES PERSONNEL**

Manual 1	Storm Damage Operations (2nd edn)	A
Manual 2	Operations Centre Management	A
Manual 3	Leadership	A
Manual 4	Land Search Operations (2nd edn—Amdt 1)	A
Manual 5	Road Accident Rescue (2nd edn)	A
Manual 6	General Rescue (4th edn—formerly Disaster Rescue)	A
Manual 7	Map Reading and Navigation (2nd edn)	A
Manual 8	Four-Wheel-Drive Vehicle Operation (Amdt 1)	A
Manual 9	Communications (2nd edn)	A
Manual 10	Flood Rescue Boat Operation (2nd edn)	A
Manual 11	Vertical Rescue (2nd edn)	A
Manual	Structural Collapse Search and Rescue	D

### **PART V —THE MANAGEMENT OF TRAINING**

Manual 1	Small Group Training Management (2nd edn)	A
Manual 2	Managing Exercises	A

---

**Key to status: A = Available; A/R = original version Available/under Review;  
D = under Development; P= Planned; R = under Review/Revision; U/R = Unavailable/under Review**





# FOREWORD

The purpose of this Manual is to provide an information base for vertical rescue operations. It is intended for use in planning, training and operations by all responsible rescue personnel and organisations.

Although its emphasis is on broad principles, the Manual acknowledges that individual States and Territories or organisations may need to provide detailed techniques which address local requirements.

Vertical Rescue, by its very nature, is a high-risk activity. The natural disasters organisation accepts no responsibility for any accident or injury caused by the misuse or misinterpretation of information contained in this Manual. The reading of this Manual alone cannot be considered adequate training for a vertical rescuer. Knowledge must be linked with training, practical experience and strict adherence to safety.

This Manual has been developed by a National Working Party representative of police, fire State and Territory emergency services and ambulance services. The working party was initiated and sponsored by Emergency Management Australia.

The Manual is issued in loose-leaf form to facilitate amendment and insertion of individual organisational supplements.

As situations change and techniques are improved and developed, the Vertical Rescue Manual will be amended and updated by the National Working Party.

**The Australian Emergency Manual—Vertical Rescue contains those techniques and skills which are relatively basic in nature and which are common to a large number of emergency services. It therefore serves as a common reference base for the basic training of personnel for vertical rescue activities.**

**It is vital that training in this field be controlled within a recognised system of accreditation and certification, and that all training be provided by accredited and experienced vertical rescue instructors.**

Proposed changes should be forwarded to the Director-General, Emergency Management Australia at the address shown below through the relevant State/Territory emergency management organisation.

The use of trade names in this Manual is not intended to be restrictive, preferential or promotional. Trade names are used where descriptive clarity is required.

This publication is provided free of charge to approved Australian organisations which may obtain copies through their State or Territory Emergency Service headquarters which maintains a distribution/amendment register.

Manuals may be supplied to other Australian or overseas requesters upon payment of cost recovery charges. Consideration is given to requests from developing countries for copies without charges.

Overseas enquiries (for free copies) and all others regarding purpose of this Manual should be sent to the Director-General, Emergency Manual Australia, PO Box 1020, DICKSON ACT 2602, AUSTRALIA, (facsimile +61 (0)2 6257 7665, email: [ema@ema.gov.au](mailto:ema@ema.gov.au)).





# CONTENTS

	Page
Information on the Australian Emergency Manuals Series	iii
Amendment Certificate	v
Foreword	vii
Contents	ix
	<b>Paragraph</b>
<b>CHAPTER 1 AN INTRODUCTION TO VERTICAL RESCUE</b>	
INTRODUCTION	1.1
RESCUE FACTORS	1.6
Aptitude and mobility	1.7
Training and Experience	1.10
Equipment Familiarity	1.13
Discipline and Teamwork	1.15
Approach and Tactics	1.19
CONCLUSION	1.21
<b>CHAPTER 2 SAFETY</b>	
INTRODUCTION	2.1
Safety Considerations	2.2
Checking, Monitoring and Being Alert	2.3
Safety Officers	2.4
Suitability of Personnel	2.5
PERSONAL EQUIPMENT	2.6
TRAINING SITE SELECTION	2.7
COMMUNICATIONS	2.8
STRENGTH OF EQUIPMENT	2.10
FINAL SAFETY CHECKS	2.13
SAFETY PROCEDURES	2.16
Vital Points	2.17
NIGHT OPERATIONS	2.18
CONCLUSION	2.20
<b>CHAPTER 3 SOFTWARE</b>	
INTRODUCTION	3.1
ROPE	3.2
Types	3.3
History	3.4
Construction	3.5
Polyamide (Nylon)	3.6
Kernmantel Construction	3.7
Dynamic Kernmantel Ropes	3.8
Static Kernmantel Ropes	3.9
Characteristics of a Synthetic Fibre Rescue Rope	3.10
Care and Maintenance	3.11
Washing Ropes	3.12

Inspection	3.13
Retiring a Rope	3.14
Identification	3.15
Rated Strength and Safe Working Load	3.16
Rope Packaging	3.17
Carrying the Rope	3.18
Flaking the Rope	3.19
Cord	3.20
Protection	3.21
TAPE	3.22
Usage	3.23
Construction	3.24
Size	3.26
Abrasion	3.27
Strength	3.28
Special Rescue Applications	3.29
Safety	3.31
HARNESSES	3.32
Industrial Safety	3.33
Mountaineering (Sit)	3.34
Free Style	3.36
Full Body Rescue	3.40
Chest	3.42
Waist Belt Loops	3.44
Harness Replacement	3.45
Harness Selection	3.46
Improvised Harnesses	3.47
<b>CHAPTER 4    KNOTS</b>	
INTRODUCTION	4.1
ROPING TERMINOLOGY	4.3
Explanation of Terms	4.4
QUALITIES OF A GOOD KNOT	4.5
KNOTS AND HOW THEY AFFECT ROPE	4.6
Thumb or Overhand Knot	4.8
Figure of Eight Knot	4.9
Figure of Eight on the Bight	4.11
Figure of Eight Loop	4.12
Tying the Figure of Eight Loop	4.13
Alpine Butterfly	4.14
Clove Hitch	4.15
Double Fishermans Knot	4.16
Round Turn and Two Half Hitches	4.17
Tape Knot	4.18
Tape Knot Safety	4.19
Prusik Knot	4.20
Klemheist Knot	4.21
Bachmann Knot	4.22
KNOT STRENGTHS	4.23
Breaking Strains	4.24

**CHAPTER 5    **HARDWARE****

INTRODUCTION	5.1
KARABINERS	5.2
Gates	5.3
Rated Strength Stamp	5.4
Care in Use	5.5
Rescue Use	5.6
Gate Openings	5.7
ACCIDENTAL GATE OPENING	5.8
Avoiding Gate Opening	5.10
Locking Karabiners	5.12
Additional Concerns with Locking Karabiners	5.14
Karabiner Usage and Safety	5.15
MAILLONS	5.17
Rescue Requirements	5.18
BELAY PLATES	5.19
FITTING	5.20
Operation	5.21
CAM BELAY DEVICES	5.23
GriGri	5.24
No Worries	5.25
DESCENDERS	5.26
Definition	5.27
Common Types	5.28
Figure 8 Descenders	5.29
In-line Variable Friction Descenders	5.30
Rappel Rack	5.31
Rescue Rappel Racks	5.32
I'D self-braking descender	5.33
ASCENDERS	5.34
Spring Ascenders	5.35
Cam Ascenders	5.36
Selection Criteria	5.37
Wear and Weakening	5.39
Care and Maintenance	5.40
Strength	5.41
PULLEYS	5.42
Characteristics of a Vertical Rescue Pulley	5.43
Specialised Pulleys	5.44
Karabiner Back-Up	5.45
Care and Maintenance	5.46
EDGE ROLLERS	5.47
STRETCHERS	5.48
Common Types	5.49
LIGHTING	5.50
Portable Lights	5.50
Floodlights and Spotlights	5.51
Strobe and Chemical Lights	5.52
EQUIPMENT RECORDS	5.54

<b>CHAPTER 6</b>	<b>ANCHORS</b>	
	INTRODUCTION	6.1
	General Principles	6.2
	TYPES OF ANCHORS	6.3
	Natural or Existing	6.4
	Assembled or Improvised Anchors	6.6
	ATTACHMENT TO ANCHORS	6.7
	Advantages of Slings	6.7
	Use of Two Slings	6.8
	Methods of Attachment	6.9
	Sling Angles and Loadings	6.11
	Load Sharing Systems	6.14
	Conclusion	6.16
<b>CHAPTER 7</b>	<b>EDGE MANAGEMENT</b>	
	INTRODUCTION	7.1
	EDGE MATS	7.5
	ROPE PROTECTORS	7.8
	EDGE ROLLERS	7.10
	ROOF ROLLERS	7.11
	RESCUE DERRICKS	7.12
	TRIPODS	7.15
	PIGTAILS	7.17
<b>CHAPTER 8</b>	<b>BELAYING</b>	
	INTRODUCTION	8.1
	Friction Devices	8.2
	Use of Standard Calls	8.3
	Terminology	8.4
	ESTABLISHING A BELAY	8.5
	Basic Principles	8.5
	Rope Management	8.6
	Belay Plate	8.7
	BELAY PLATE OPERATION	8.8
	Shock Load Control	8.9
	Locking the Plate	8.10
	The Grigri Belay	8.11
	Operating the GrIGri	8.13
	The Italian Friction Hitch	8.15
	Locking the Hitch	8.16
	BELAY CALLS	8.17
	Procedure	8.18
	SAFETY	8.19
	CONCLUSION	8.20

<b>CHAPTER 9</b>	<b>DESCENT</b>	
	INTRODUCTION	9.1
	Abseiling	9.1
	SAFETY NOTES	9.3
	Lowering	9.4
	Reversing Procedure	9.5
	Rope Protection	9.6
	DESCENT OPERATIONS	9.7
	Procedure	9.7
	Control and Balance	9.8
	Completion	9.9
	Bottom Brake Operator	9.10
	DESCENT DEVICES	9.11
	EMERGENCY DESCENT METHOD	9.12
	CHANGING FROM DESCENT TO ASCENT	9.13
	Procedure	9.13
	GENERAL SAFETY	9.14
	Standard Calls	9.17
	Response	9.18
<b>CHAPTER 10</b>	<b>ASCENT</b>	
	INTRODUCTION	10.1
	ASCENT EQUIPMENT	10.2
	Rope Protection	10.3
	Belays	10.4
	ASCENT SYSTEMS	10.5
	The Frog Ascent Rig	10.5
	The Frog Rig with Prusik Knots	10.6
	The Frog Rig with Mechanical Ascenders	10.7
	OTHER ASCENT SYSTEMS	10.8
	CHANGEOVER FROM ASCENT TO DESCENT	10.9
	Procedure	10.9
	CONCLUSION	10.10
	General Suitability	10.10
	Practise	10.11
	Reverse Procedure	10.12

**CHAPTER 11 LIFTING/LOWERING SYSTEMS**

INTRODUCTION	11.1
Common Scenarios	11.2
INCORPORATION OF SAFETY BELAYS	11.4
Requirement	11.4
Back-up	11.5
LOWERING SYSTEMS	11.7
Direct Lower	11.8
Friction Lower	11.9
LIFTING SYSTEMS	11.10
The Basic Hauling System	11.12
BASIC MECHANICAL ADVANTAGE SYSTEM	11.17
DUTIES OF THE HAULING TEAM	11.22
HAULING OPERATION CALLS	11.24
CONCLUSION	11.26

**CHAPTER 12 STRETCHER OPERATIONS**

INTRODUCTION	12.1
CASUALTY PACKAGING	12.2
BASIC PRINCIPLES	12.5
STRETCHER RIGGING	12.6
HORIZONTAL METHOD	12.8
VERTICAL METHOD	12.9
TESTING THE RIG	12.10
THE ESCORT	12.11
TWO ESCORTS	12.13
UNESCORTED STRETCHERS	12.15
CROSSING EDGES	12.17
CONCLUSION	12.20

**CHAPTER 13 OPERATIONAL MANAGEMENT**

INTRODUCTION	13.1
COMMAND AND CONTROL	13.3
LEGAL ASPECTS	13.6

# CHAPTER 1

## AN INTRODUCTION TO VERTICAL RESCUE

### INTRODUCTION

- 1.1 Vertical rescue is one of the most hazardous and technical forms of rescue activity. The degree of training, teamwork and individual commitment required to effect the recovery of a person trapped in a vertical environment is of the highest order, and it must be clearly understood that not all rescuers will become competent in the required techniques.
- 1.2 Of all the attributes of a vertical rescuer, a high degree of aptitude and a high standard of personal mobility are probably the most vital.
- 1.3 A one hundred metre cliff, radio mast or mine shaft is totally alien to anyone who normally works on the flat and level, and a great deal of practice is required before such an individual becomes comfortable in that environment.
- 1.4 Added to this environmental consideration is the risk factor. A minor slip, trip or error at ground level seldom has any serious consequence, but the same mistake at height can spell disaster.
- 1.5 The skills, which go together, to make up vertical rescue are tested and safe, but the actual performance of these skills relies on a number of major factors.

### RESCUE FACTORS

- 1.6 The major factors involved in any vertical rescue are:
  - a. aptitude and mobility;
  - b. training and experience;
  - c. equipment familiarity;
  - d. discipline and teamwork; and
  - e. approach and tactics.

#### 1.7 APTITUDE AND MOBILITY

To be effective, rescuers must be comfortable in high places, and be confident in their own abilities, teammates and equipment.

- 1.8 A fear of heights or open spaces may not cause concern in rescue operations at ground level, but on a cliff or high structure, they can render a rescuer totally ineffective.
- 1.9 No-one should ever totally lose respect for high places, or the apprehension, which accompanies that first step into space, but it must never interfere with the operation.

#### 1.10 TRAINING AND EXPERIENCE

There is no substitute for training and experience in vertical rescue.



**1.11** The vertical rescuer must be thoroughly trained in all basic rescue skills, and able to use these skills in the vertical environment.

**1.12** Frequent exercises must be held to ensure that training levels are maintained. **Practice, practice then even more practice.**

### **1.13 EQUIPMENT FAMILIARITY**

Rescuers must be totally familiar with all of the items of equipment, breaking strains, and the way equipment reacts to stresses or loads.

**1.14** Every rescuer should be competent to check and maintain equipment in the field, and should take steps to assist in overall equipment maintenance programs.

### **1.15 DISCIPLINE AND TEAMWORK**

Discipline and teamwork are critical to any vertical activity, and their absence can negate any individual efforts.

**1.16** A vertical rescuer must rely completely on a team member belaying, or the entire team on the lowering rope. He or she depends on the team leader making decisions, and on the simple fact that everyone else checked their part of the system, monitored by the Safety Officer (refer Chapter 2).

**1.17** Orders must be obeyed immediately, and the entire operation must be conducted efficiently.

**1.18** Teamwork must be of a very high standard. Every member of the team must be trained, confident, disciplined, and must be safety conscious at all times.

### **1.19 APPROACH AND TACTICS**

The team leader must make an appreciation of the situation. This includes:

- a. determining the aim;
- b. considering the factors;
- c. considering the courses of action; and
- d. formulating the plan.

**1.20** Communications between the casualty, the rescuer and the team must be maintained at all times.

#### **WARNING NOTE**

**NO RESCUER SHOULD EVER BE GIVEN OR ACCEPT A TASK WHICH HE/SHE IS INCAPABLE OF PERFORMING IN A SAFE AND COMPETENT MANNER.**

## **CONCLUSION**

**1.21** Vertical rescue is a highly technical skill, demanding teamwork, discipline and training. It is essential that rescuers are thoroughly prepared psychologically and physically before tackling vertical operations.

# CHAPTER 2

## SAFETY

### INTRODUCTION

**2.1** The safety of all concerned in a vertical activity is essential, and it is the responsibility of each individual to ensure that all safety precautions are strictly observed.

### **2.2 SAFETY CONSIDERATIONS**

Safety and the reduction of the risk inherent in any vertical activity depend upon:

- a. proper and recent training;
- b. the maintenance of equipment and standards;
- c. care and a commonsense approach to the task;
- d. attention and observation;
- e. teamwork; and
- f. proper briefing and 'on-task' communications.

### **2.3 CHECKING, MONITORING AND BEING ALERT**

Safety is an ongoing feature of this activity. Throughout, there will be anchors and knots to check, ropes to monitor, systems to rig and dismantle. All personnel must remain alert throughout and operate safely at all times.

### **2.4 SAFETY OFFICERS**

Suitably experienced vertical rescue personnel must be appointed as Safety Officers for any vertical rescue activity. They are responsible for all aspects of safety.

### **2.5 SUITABILITY OF PERSONNEL**

To ensure safety is maintained during training and operations the key factors which need to be considered when selecting personnel are:

- a. physical fitness to perform the task;
- b. aptitude for the task (including phobias); and
- c. ability to work as a team member.

## PERSONAL EQUIPMENT

2.6 The following equipment is considered a minimum safety requirement for vertical rescue activities:

- a. **Helmet**—A rated rescue, climbing or caving helmet is the only acceptable style for vertical work, and the basic design and characteristics shown in Figure 2–1 should be taken as a standard. The helmet must be capable of being fitted with a helmet light. Helmets must be worn in accordance with manufacturers specifications.

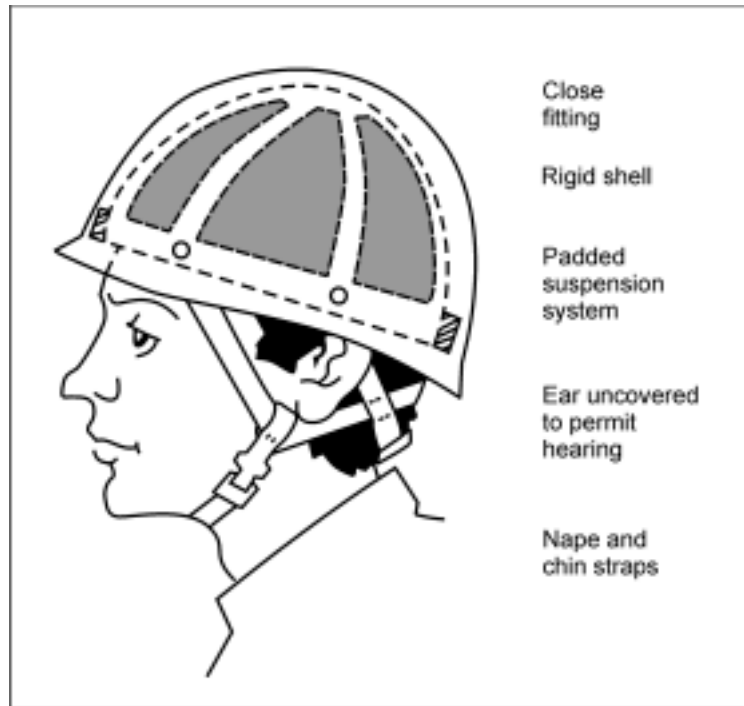

Figure 2–1: Helmet Characteristics

- b. **Gloves**—These are an essential part of protection. They should be close fitting leather for all abseiling and belaying to prevent friction burns and loss of control.
- c. **Boots**—Regardless of the boot selected, the sole must have a good pattern, and must be in good condition with plenty of 'grip'. The boot should fit properly, and it must be maintained in a proper manner for comfort and safety.
- d. **Clothing**—The most important aspects of clothing are that it must protect the wearer and should not be too loose fitting or have loose pieces to risk entangling in roping systems.
- e. **Harness**—Any person working in the vertical environment requires the protection and safety of a vertical rescue harness approved by the respective emergency rescue agency.
- f. **Whistle**—All persons involved in vertical activities should carry a whistle as part of their personal equipment.
- g. **Self-Rescue Equipment**—A simple means of self rescue.

- h. **Knife**—A sharp knife should be carried on a lanyard.
- i. **First Aid Kit**—A personal first aid kit should also be carried.

#### **WARNING NOTES**

- 1. CARE MUST BE TAKEN WITH LONG HAIR, RINGS, WATCHES, LACE HOOKS ON BOOTS AND THE LIKE TO ENSURE THAT A SAFETY HAZARD IS NOT CREATED.**
- 2. LOAD BEARING EQUIPMENT MUST ONLY BE MANUFACTURED, MODIFIED OR REPAIRED BY AN APPROPRIATELY QUALIFIED PERSON.**

### **TRAINING SITE SELECTION**

- 2.7** Training sites need to be selected with the following safety considerations in mind:
- a. The condition of the selected site [stability, sharp edges etc.
  - b. Adequate top safe working area between anchors and the edge.
  - c. A safe, clear area at the base level.
  - d. Accessibility.
  - e. First aid and casualty evacuation.
  - f. Site relevance to standard of training required.
  - g. Communications.

### **COMMUNICATIONS**

- 2.8** To avoid confusion, all must understand and use standard calls or signals without hesitation. Additionally, area noise must be minimised to reduce interference with calls or signals. Recommended standard calls are shown in appropriate chapters.
- 2.9** Some situations may require the use of radio equipment, and voice activated systems should be considered for 'hands free' operation.

### **STRENGTH OF EQUIPMENT**

- 2.10** Vertical rescue equipment has either a stated, rated strength or satisfies a recognised Standard. Personnel must know the rated capabilities of all items used in vertical activities.
- 2.11** When several items of equipment are being used together in a rescue system, the overall load capability of the system must be based on the item of equipment with the lowest rated strength.
- 2.12** State authorities must determine their policies with regard to rated strengths, safety factors and safe working loads.

## FINAL SAFETY CHECKS

- 2.13 All personnel must be finally checked by the Safety Officer before commencing work in a vertical environment.
- 2.14 Each component of the total system, such as anchors, rope and personal equipment, must be checked, as well as the personal braking method and emergency procedure.
- 2.15 The final check must include a confirmation of task details and safety systems such as bottom belays.

## SAFETY PROCEDURES

- 2.16 Personnel not directly involved in the conduct of the operation must be kept clear of the working area.

### 2.17 VITAL POINTS

The following points **must** be observed:

- a. Every vertical activity must be treated as potentially life threatening.
- b. All equipment must be checked properly before, during and after use.
- c. A safety area must be cleared extending approximately two metres back from the edge. No one should be permitted into this area without a safety line.
- d. A safety area must be established around the base of a mast or tower, or at a cliff or structure base where vertical activities are under way.
- e. Operations must be carried out under the strict control of the team leader, therefore all personnel must be alert and ready to receive orders at all times.
- f. Anchors must be set up with due regard to the load they may be required to bear, and they must be monitored at all times.
- g. All knots and rope friction areas must be monitored throughout the rescue operation.
- h. Spare rope and equipment must be kept clear of work areas.
- i. Personnel must **never** stand on rope, and should exercise great care when required to step over a rope under load. Care must be taken to ensure that ropes are **not** laid out or left in high traffic areas.
- j. Where ropes are run out over rough or sharp edges, they must be protected with padding or edge rollers.
- k. Rope on rope contact must be avoided, particularly where an active [moving] rope may abrade against a fixed [static] rope and cause a 'melt through'.
- l. Persons working at a cliff top or on a cliff face must take care not to dislodge loose rocks on those below. Similarly, equipment must never be thrown from any height to a crew below. Any accidental dropping or dislodging of an object must immediately be advised by the shouting of the single word warning '**below**'.
- m. In those cases where a rope must be thrown from a height, the person must first give the warning shout '**rope below**'.

- n. Persons working on heights or at cliff or structure bases must wear helmets with the chinstrap securely in place.
- o. Any loose items (including spectacles) must be secured to prevent loss or damage, or injury to others.
- p. Rescuers must wear suitable footwear.
- q. Personnel must wear gloves for protection when belaying or abseiling.
- r. Any person abseiling must carry self rescue equipment.
- s. Each rescuer should carry a whistle and sharp knife on a lanyard.

## **NIGHT OPERATIONS**

**2.18** During vertical rescue operations at night, the following must be considered:

- a. Individual helmet lights,
- b. secondary light sources for individuals,
- c. diffused lighting for work areas, and
- d. chemical light tubes to identify key personnel or equipment.

### **WARNING NOTE**

**PORTABLE GENERATORS CAN CREATE SAFETY HAZARDS WITH ELECTRICITY, HEAT, NOISE AND CARBON MONOXIDE. APPROPRIATE SAFETY MEASURES MUST BE EMPLOYED.**

**2.19** Some form of physical cordon should be established wherever possible, to keep people away from danger areas.

## **CONCLUSION**

**2.20** Safety is the responsibility of all personnel throughout any vertical rescue operation, and the duty of the Safety Officer.



# CHAPTER 3

## SOFTWARE

### INTRODUCTION

3.1 This chapter is designed to provide a working knowledge of the use, care and maintenance of ropes, tapes, slings and harnesses.

### ROPE

3.2 Rope is the primary tool of the vertical rescuer, and it therefore follows that personnel involved in this skill should have a thorough understanding of the types and properties of rope and of rope management techniques.

### 3.3 TYPES

In almost all cases, rescue rope will be of synthetic fibre kernmantel construction. This chapter therefore deals exclusively with ropes of this type. For information on other rope types, refer to the Australian Emergency Manual—General Rescue.

### 3.4 HISTORY

A rope's performance, durability and safety depend on how well it is cared for. The condition of a rope is dependent on its history, age, conditions to which it has been subjected, and the care it has received. Agencies should have a system of recording a ropes history, such as the example record card shown in Figure 3-1.

ROPE HISTORY CARD				
Rope type: BLUE WATER 2 + STATIC		Size: 50mL 11mm		No: _____
Date Acquired: 2.7.2000		Source: SCOUT OUTDOOR CENTRE		
Date	Used by	Use	Comment	Checked
2.7.91	—	TO STORE	IN DROP BAG	<i>CS</i>
3.11.91	RESCUE OFFICER	TO RESCUE VEHICLE	O.K.	<i>CS</i>
1.11.91	SYMONS	20M ABSEL (W TAIL)	PROTECTION ON EDGE MINIMAL DAMAGE	<i>CS</i>
8.12.91	CALLBON	3 RECOVERING 40m LOAD LINE	O.K WASHED + CLEARED	<i>CS</i>

Figure 3-1: Rope History Card



### 3.5 CONSTRUCTION

The manufacture/construction of synthetic ropes is described below:

- a. The manufacture of synthetic fibre rope commences with a chemical process which produces the raw material, such as Nylon or Terylene. The material is then melted and extruded through holes in a metal disc to produce long and fine filaments.
- b. The filaments are then stretched and cooled, with the amount of stretch determining some subsequent rope properties. In basic terms, higher stretching during filament manufacture will result in a rope with higher tensile strength and lower stretch in use.
- c. The filaments are then bunched to form yarns. Synthetic rescue rope should be of 'continuous filament' construction, with each filament being a continual length throughout the rope. It is generally easier to detect a continuous filament rope, as it will be smooth and shiny in appearance, without the 'hairy' appearance of 'staple' or short filament ropes.

### 3.6 POLYAMIDE (NYLON)

There are actually several different types of Polyamide. The two most commonly used in the manufacture of rescue rope are Nylon 6—also known as Perlon, and Nylon 6.6.

- a. **Advantages**—These, for Polyamide over Polyester (Terylene) and other rope filaments, are as follows:
  - (1) Polyamide is about 10 per cent stronger than Polyester.
  - (2) The material has excellent shock absorption characteristics.
  - (3) Nylon 6.6 has one of the highest melting points at around 260 degrees C.
- b. **Disadvantages**—Polyamide's disadvantages are:
  - (1) It may lose up to 15 per cent of its strength when wet (and regain this loss on drying out).
  - (2) It is readily affected by contamination by acids.
- c. Polyamide ropes are commonly used in life support applications, including rescue, climbing and caving.

### 3.7 KERNMANTEL CONSTRUCTION

Construction of kernmantel ropes is described below:

- a. The term **kernmantel** comes from a compound German word:  
**kern**—core  
**mantel**—sheath
- b. The kernmantel style of construction therefore consists of a kern or core of filaments designed to sustain the greater part of the load. This core is covered by a woven or braided sheath which supports a lesser portion of the load, but which provides protection for the core against abrasion, dirt and sunlight (ultra-violet light).
- c. This construction style provides a rope which is strong and resistant to damage, yet is light and easy to handle. These ropes also tend to be highly resistant to spin or twist.

- d. The two basic types of kernmantel ropes are:
  - (1) dynamic ropes; and
  - (2) static ropes.

### 3.8 DYNAMIC KERNMANTEL ROPES

Characteristics and properties are as follows:

- a. **Elasticity and Elongation**—A dynamic rope is one manufactured with a very high degree of elasticity (or stretch) so that it can absorb high shock loadings such as can be generated by a falling climber. Some dynamic climbing ropes may elongate by as much as 60% before breaking.
- b. **Core Patterns**—Elongation in the rope is the result of the stretching of the core filament bundles under load. Different manufacturers and different rope styles have core patterns which vary. Examples of core patterns are shown in Figure 3–2.
- c. **Strength**—The mantle or sheath of the rope is comparatively thin, serving as it does, to protect the core, and contribute slightly to overall rope strength.
- d. **Advantage**—A dynamic rope has greater ability to absorb shock impacts caused by falling persons.
- e. **Disadvantage**—The primary disadvantage of dynamic rope for rescue is its elasticity. The very high degree of stretch tends to be a problem when descending, ascending or hauling.

#### WARNING NOTE

**DYNAMIC ROPES SHOULD NOT BE USED IN VERTICAL RESCUE SYSTEMS.**

### 3.9 STATIC KERNMANTEL ROPES

Characteristics and properties are as follows:

- a. **Elongation**—A static rope is one designed with low elongation characteristics. These ropes normally elongate around three per cent under one persons body weight, and not more than twenty per cent at ultimate breaking point.
- b. **Elasticity**—The stretch in a static rope is normally attributable to the elasticity of the rope filaments. Static ropes have poor shock absorbing qualities, and any shock loading subjects the rescuers body, the equipment in the system, and the anchor system to high impact forces.
- c. **Strength vs Handling**—Static ropes tend to have thicker sheaths for greater core protection. The increased sheath contributes more to the overall rope strength, but results in a stiffer rope with relatively poorer rope handling characteristics.
- d. **Advantages**—These for a static rope design are:
  - (1) low stretch;
  - (2) resistance to abrasion and intrusion of damaging dirt and grit; and
  - (3) high tensile strength.

- e. **Disadvantages**—These, for static ropes are:
- (1) poor capacity for shock absorption; and
  - (2) stiffer handling and knotting.

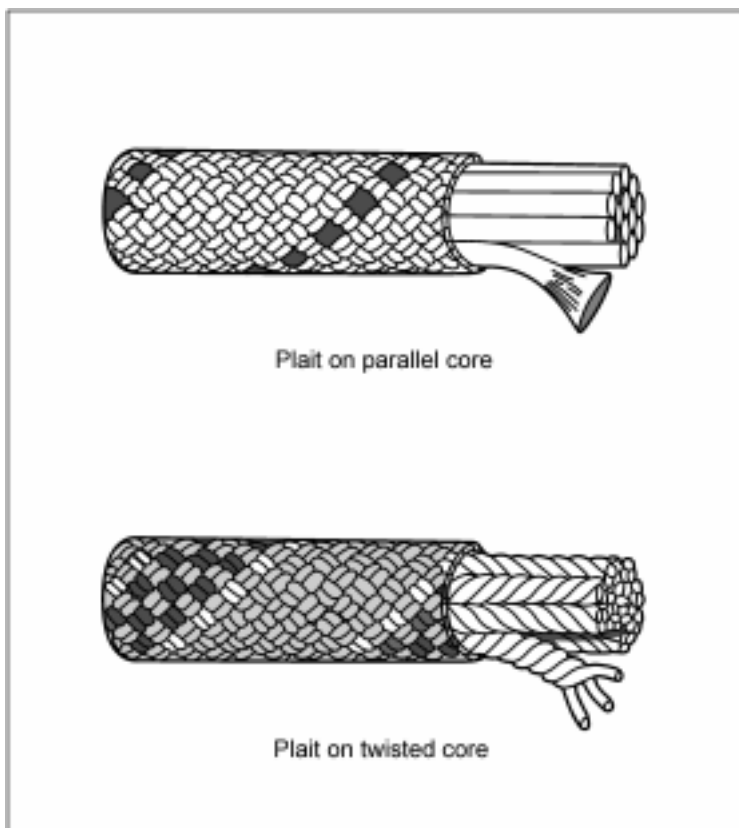

Figure 3–2: Examples of Kernmantel Rope Construction

**WARNING NOTE**

**ALL ROPES USED IN A RESCUE SYSTEM MUST HAVE IDENTICAL CHARACTERISTICS TO AVOID UNEQUAL ROPE STRETCH AND LOAD REACTIONS.**

**3.10 CHARACTERISTICS OF A SYNTHETIC FIBRE RESCUE ROPE**

The criteria for synthetic fibre rescue ropes are laid down in Australian Standard AS 4142.3–1993—‘*Fibre Ropes—Man-Made Fibre Rope for Static Life Rescue Lines*’, and comprise:

- a. minimum diameter 11 mm;
- b. static kernmantel construction;
- c. minimum rated strength 3000 kg;
- d. 100 per cent Polyamide (Nylon);
- e. spin resistance;
- f. good handling and knotting properties;
- g. maximum three per cent elongation at 80 kg load;

- h. minimum 20 per cent elongation at 3000 kg load;
- i. temperature tolerant to meet operational requirements; and
- j. contrasting core and sheath colours.

### **3.11 CARE AND MAINTENANCE**

The following points should be observed:

- a. Avoid cutting a rope unless it is essential to do so. If it is necessary, ensure the cut end is heat sealed as soon as possible to prevent fraying. (As a temporary measure, tie a Figure of Eight knot near the end of the rope or secure it with adhesive tape.)
- b. Do not leave knots in a rope as they can reduce its strength by damaging the fibres.
- c. Always use proven knots and fastenings for ropes. Sharp bends or knots can overload elements of the rope. Swaged eyes at rope ends should be avoided.
- d. Use the correct size sheave in pulleys. Any attempt to force a thick rope through a smaller pulley will cause damage.
- e. Avoid sudden jerks or violent stress on the rope.
- f. Avoid stepping or walking on rope as this will force damaging grit and dirt into the fibres.
- g. Avoid passing a rope over a sharp edge or rough surface. If it is necessary to do this, protect the rope with sacking or other material.
- h. Ropes which have been hauled through mud, sand or grit should always be cleaned after the work has been completed. This is best managed by washing the rope in fresh, running water, and following any manufacturers recommendations.
- i. Do not dry ropes in front of a fire or other heat source. Spread the rope on a ladder, laid horizontally off the ground in a cool, shady area to enable the air to circulate freely around the rope.
- j. Store ropes in a neutral environment under cover, off the floor, preferably in racks in a place free from the extremes of temperature and out of contact with any contaminating materials, moisture, dust, rodents and sharp edges.
- k. Damaged or defective ropes must be appropriately labelled and removed from service immediately. Details must then be entered on the rope history record card.
- l. Ropes should not be exposed to direct sunlight for prolonged periods as the fibres will degrade due to ultra-violet radiation. If a rope has to be stored in an exposed location, cover it with a tarpaulin or some other form of protection.
- m. Ensure no contact is made with contaminants such as grease, oil, petrol, hydraulic fluid, acids, alkalis and chemicals.

### **3.12 WASHING ROPES**

The following points should be observed:

- a. Ropes must be washed when dirty to reduce the effect of grit abrasion on both the rope and abseil or ascent equipment. The rope can be chained (Refer Figure 3–5) and placed in a pillow case to prevent tangling.

- b. Polyamide ropes can be washed in a washing machine, but the machine must be set on the gentle wash cycle and cold or warm setting (**never on hot**), and no washing agents or fabric softeners should be used. Where help is needed to clean a rope, refer to the rope manufacturers specifications.
- c. Where a manufacturers recommendations include the use of some form of very mild washing agent, the rope must be thoroughly rinsed in clean water to remove residual traces of the washing agent.
- d. The washed rope can be pulled under very slight tension through an in-line descender to remove excess water, and the rope dried in a cool, shady area with good ventilation.

### 3.13 INSPECTION

All rescue ropes should be inspected before, during and after use. The inspection should be conducted by **visually examining** the rope, and by thoroughly **feeling** the rope.

- a. **Visual Examination**—This should cover checks for the following:
  - (1) **Discolouration of Filaments**—Any changes in the original colour of the rope filaments could indicate contamination by chemicals.
  - (2) **Melting**—Any smooth areas could indicate the rope has been damaged by heat fusion.
  - (3) **White Filaments**—Where the sheath has been damaged, the white core filaments may protrude through it.
  - (4) **Size Uniformity**—The rope may have been damaged by mechanical impact or over-stressing. This may be evidenced by a change in the obvious shape and diameter of the rope.
  - (5) **Abrasion**—Excessive signs of abrasion may indicate the breaking of a sheath bundle and localised weakness.
  - (6) **Stiffness**—Any inconsistency in the texture of the rope and its stiffness. A bight of rope should have uniform radius around the bend, and inconsistencies may be soft spots which indicate core damage.
- b. **Checking by Feel**—Every part of the rope should be passed through the bare hands, feeling for the following:
  - (1) **Stiffened Filaments**—Thus indicating possible over-loading or contamination.
  - (2) **Changes in Diameter**—Depressed irregularities in the rope diameter (soft spots) may indicate core damage, while increases in the apparent diameter may be due to severe twisting of the core, or the protrusion of core filaments through the sheath.
  - (3) **Contamination**—Seek out dirt or other materials.

#### WARNING NOTE

**LOAD TESTING OF RESCUE ROPES IS NOT RECOMMENDED AS A SAFE PRACTICE.**

### 3.14 RETIRING A ROPE

It is currently impossible to properly test a rope without destroying it, and the decision to retire a rope from service must therefore be based on careful inspection by a Safety Officer. The following guidelines will assist in deciding when to retire a rescue rope:

- a. **Abrasion**—As a general rule, when more than half of the sheath yarns are broken, or the abrasion ‘fuzz’ stands out from the sheath more than 25 per cent of the rope diameter.
- b. **Loading**—Where the rope is known to have sustained a shock loading or to have been over-loaded, it should be retired.
- c. **Contamination**—Unless the material with which the rope has come into contact is known to be harmless, it should be considered as contaminated.
- d. **Texture**—A lack of uniformity of texture such as soft or hard spots.
- e. **Diameter**—Variations in the observable diameter of the rope such as the ‘hourglass’ narrowings which indicate core damage.
- f. **Sheath Penetration**—Where the white core filaments are visible through a hole in the sheath, or where the core protrudes through the sheath as a white filament ‘puff’.

In any event, the bottom line with regard to rope retirement must always be:

<b>WHEN IN DOUBT—THROW IT OUT</b>
-----------------------------------

### 3.15 IDENTIFICATION

A system of marking each end of a rope for identification of length and with a reference number to the rope history card is recommended.

### 3.16 RATED STRENGTH AND SAFE WORKING LOAD

The rated strength of rescue ropes is shown in Table 3–1. **Note: For synthetic fibre rescue rope only**, Standards Australia recommend that a safety factor of not less than eight be considered as an appropriate margin of safety to reflect ageing, environmental effects, and less than ideal usage, including the tying of knots in the rope during its use.

<b>WARNING NOTE</b>
<b>USERS MUST ENSURE THAT EQUIPMENT USED IN CONJUNCTION WITH THE ROPE IS SUITABLE FOR THE TASK IT IS REQUIRED TO PERFORM.</b>

Rope Diameter	Min. Rated Strength	Safe Working Load
[mm]	[kg]	[kg]
11	3000	375
12	3300	412
13	3600	450
14	3900	487
15	4200	525
16	4500	562

**Table 3–1: Minimum Rated Strength and Safe Working Load [from Standards Australia]**

### 3.17 ROPE PACKAGING

There are a number of techniques suited to the packaging of rescue ropes, as described below:

- a. **Coiling**—Ropes of up to 50 m in length can be rapidly coiled and finished off with frapping turns as shown in Figure 3–3. It should be noted that coiling will kink a rope, and that 'hanking' is the preferred technique.

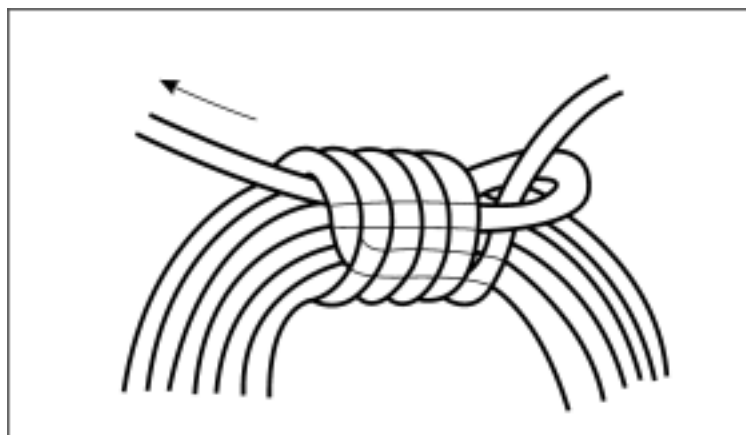

**Figure 3–3: Securing a Rope Coil**

- b. **Hanking**—This is also effective for 50 m or shorter lengths of rope, and is quite effective with doubled ropes. Grasp the rope about two metres from one end and at full armspan distance form bights in the rope laying them on alternate sides of your hand. Continue until four metres from the other end. Frap the next two metres around the bundle of rope just beneath your hand working up towards your hand. With the remaining two metres, push a bight through the hole where your hand was (between the frapping and the doubled rope bight), invert it over the head of the hank and pull tight. Figure 3–4.

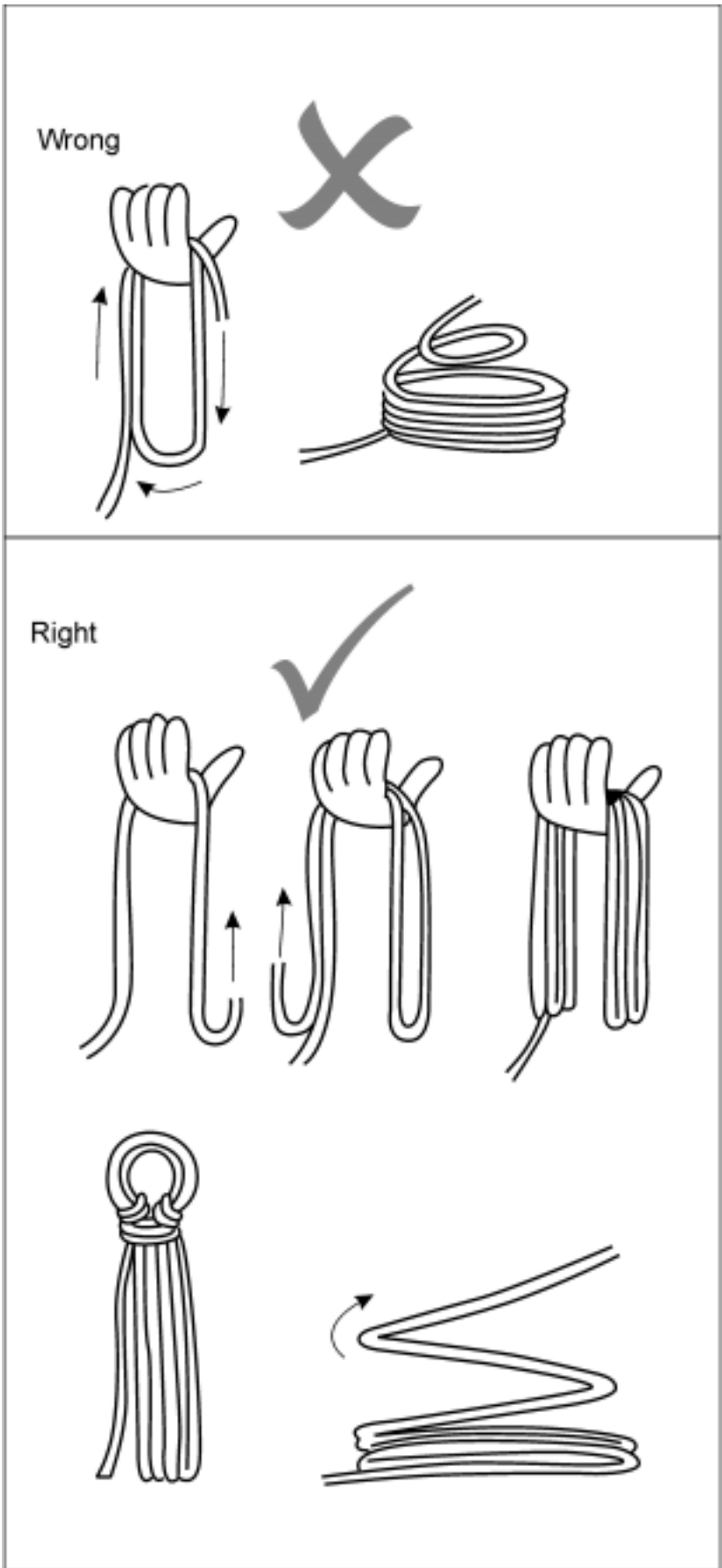

Figure 3-4: Hanking a Rope



- c. **Chaining**—This is a technique which can be used for ropes of any length, and which reduces the final length of the packaged rope. This is useful when washing ropes in a washing machine or for operational packaging. The rope can be chained as a single length, or doubled and then re-doubled as shown in Figure 3–5.

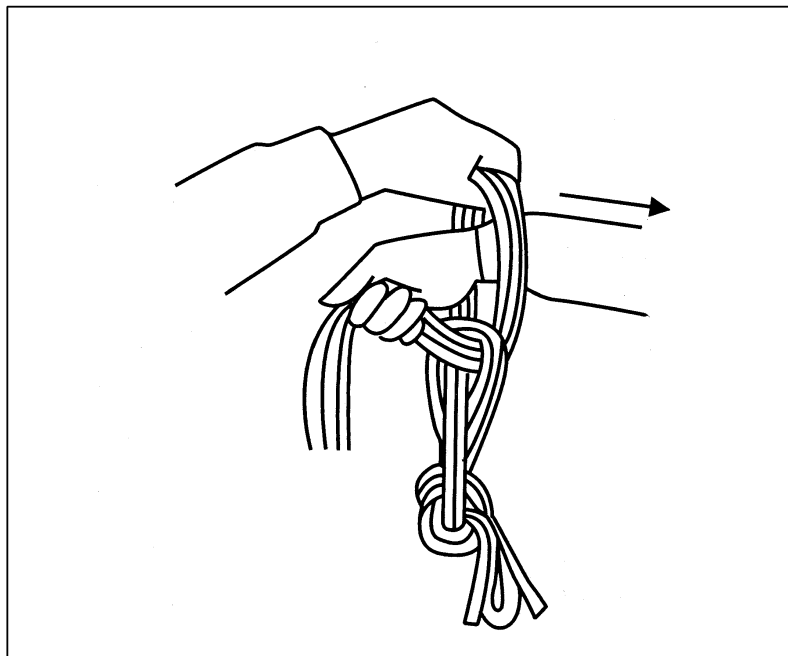
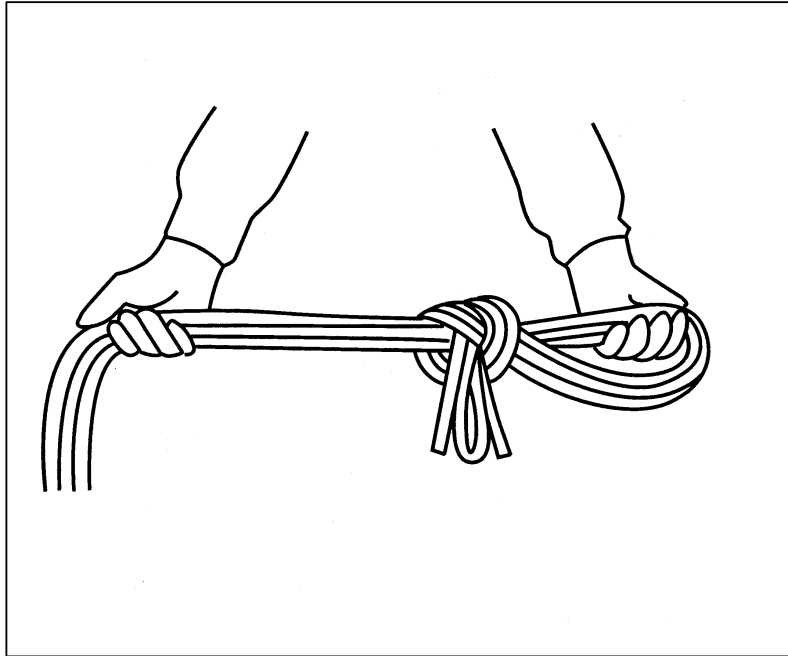

Figure 3–5: Chaining a Rope

- d. **Stuff Sacks**—These are the preferred method of storage and carriage for all ropes, but particularly long length ropes, and as the name implies, the rope is merely stuffed into the pack and gently tamped down. The sacks can be simply bags, or packs with straps for carriage to the site.

### 3.18 CARRYING THE ROPE

Sacked ropes are easy to carry where the sack is fitted with rucksack straps, and coiled or hanked ropes can be carried as shown in Figure 3–6. Chained ropes can be carried in packs, or draped over the shoulder.

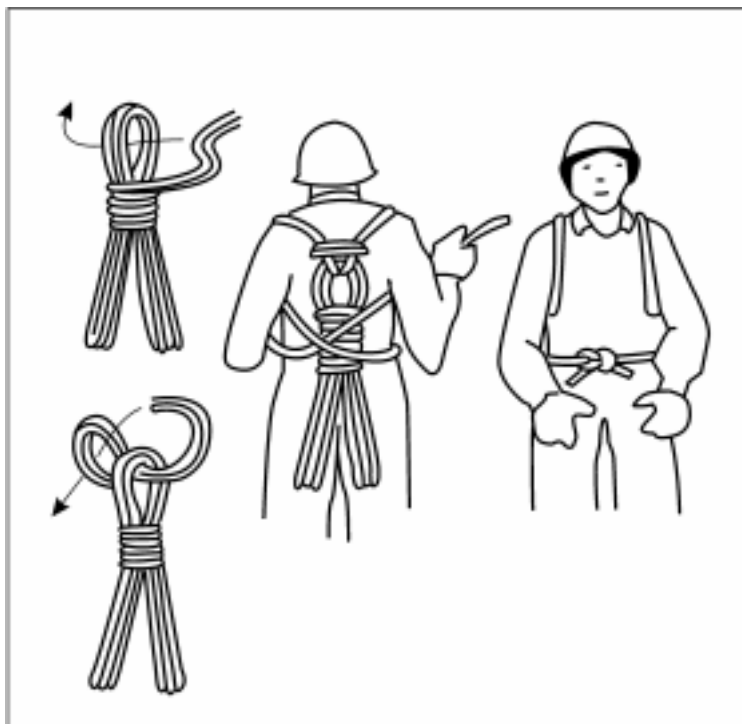

Figure 3–6: Carrying a Hanked Rope

### 3.19 FLAKING THE ROPE

Where ropes are not carried in stuff sacks, they should be inspected and 'flaked' or laid out for deployment on a tarpaulin or on clear ground to ensure that it will pay out without knots or tangles.

### 3.20 CORD

Kernmantel rope of diameter less than 9 mm is commonly referred to as cord, and is generally of static construction for a wide range of applications. The rated strength of cord will vary between manufacturers, however the following are approximate strengths for the most commonly used sizes:

6 mm	700–750 kg
7 mm	1000–1200 kg
8 mm	1200–1500 kg

These cords are used in vertical rescue for a range of purposes such as Prusik loops, belay plate tethers, edge roller ties or mat guy lines.

### 3.21 PROTECTION

Causes of rope damage and methods of avoidance and protection follow:

a. **Causes of Damage:**

- (1) **Impact**—Objects such as rocks which fall on a rope, particularly when it is under load, can cause serious damage. It is very difficult to protect ropes from this type of damage, and where a severe impact is known to have occurred, the rope must be retired. At the very least, the rope must be carefully inspected for signs of damage.
- (2) **Rough Edges**—The most common form of rope damage is caused by abrasion, and in most cases, this is entirely avoidable. This form of damage commonly occurs when a loaded rope is raised or lowered across a rough or sharp edge. It can also occur when a rescuer is ‘bouncing’ during an abseil, or when ascending a fixed rope.
- (3) **Hardware**—Whilst not common, rescue hardware which has not been properly maintained can abrade a rope. All rope management equipment must be regularly checked for burrs or other rope damaging features.

- b. **Avoiding Abrasion**—There are numerous ways of avoiding abrasion, and every team should carry equipment for this purpose as described in Chapter 7—Edge Management.

## TAPE

**3.22** Tape or webbing is one of the most versatile materials available to rescuers. It is used as tied or sewn slings, and its applications are limited only by the imagination of the rescuers.

### 3.23 USAGE

Tape slings are used to make improvised harnesses, casualty support systems, rope climbing stirrups, anchor attachments and to link rescue tackle together. Only tape specifically made for rescue, climbing or caving by recognised equipment manufacturers should be used for vertical rescue.

### 3.24 CONSTRUCTION

There are two broad design categories of tape, flat and tubular. Both types are actually flat in appearance. However, if tubular tape is viewed in cross section, it forms a hollow tube. Standard tubular tape is normally the strongest and most flexible form, and is therefore recommended for vertical rescue.

**3.25** Tape is woven in many different ways, and the characteristics which can be effected by the style of construction are strength, elongation, abrasion resistance, and ultra-violet resistance. All of these factors are affected by the fibre used and the weave tension in particular. While a tape with a very tight weave will be very strong, knot retention and suppleness will be poor. Obviously, a good rescue tape must be a compromise of all factors.

### 3.26 SIZE

Polyamide tape is sized by flat width, with 25 mm and 50 mm being the most commonly used sizes. Smaller tape sizes may be used for some techniques, but are not recommended for general vertical rescue work.

### 3.27 ABRASION

Under certain circumstances, tape is liable to abrade or wear more rapidly than rope, and yet it has no sheath for extra protection. Additional attention must be paid to wear or friction areas, and tapes must be discarded when doubt exists as to its safety.

### 3.28 STRENGTH

For vertical rescue operations, only tape with a minimum rated strength of 1500 kg should be selected. When tape is tied or sewn into a sling, the **theoretical strength** of the sling is twice that of the tape used. In practice, this strength is reduced by knot strength loss and other factors, and the actual strength of a tied sling is approximately two thirds of the doubled material rated strength.

$$1500 \times 2 \times 2/3 = 2000 \text{ kg}$$

### 3.29 SPECIAL RESCUE APPLICATIONS

As previously stated, tape is normally used in the form of sewn or tied slings for all manner of anchorage tasks, improvised harnesses, casualty slings and other attachments. During rescue operations, there may be occasions when an extra large tape sling is required for anchorage or attachment.

**3.30** The team equipment should include various sized slings. This is the preferred method as strength loss due to knotting is minimised by the use of a single sling. As a very rapid means of forming a large or extra large sling, one or more tapes can be joined by means of a version of the Reef Knot as shown in Figure 3–7, or by untying two tape slings and tying them together as one large sling.

#### WARNING NOTE

**ALWAYS CHECK TAPE KNOTS BEFORE USING SLINGS.**

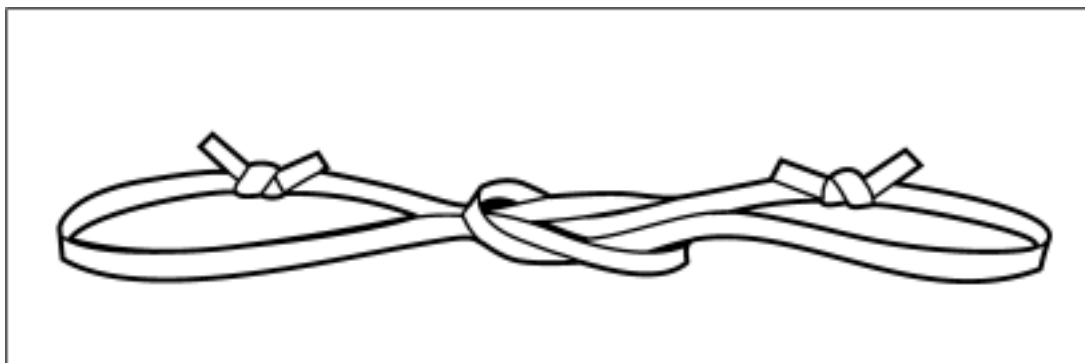

Figure 3–7: The Reef Knot Technique for Joining Tape Slings

#### WARNING NOTE

**THE LARKS HEAD SLING JOINING METHOD (FIGURE 3–8) REDUCES THE STRENGTH OF SLINGS AND IS NOT SAFE.**

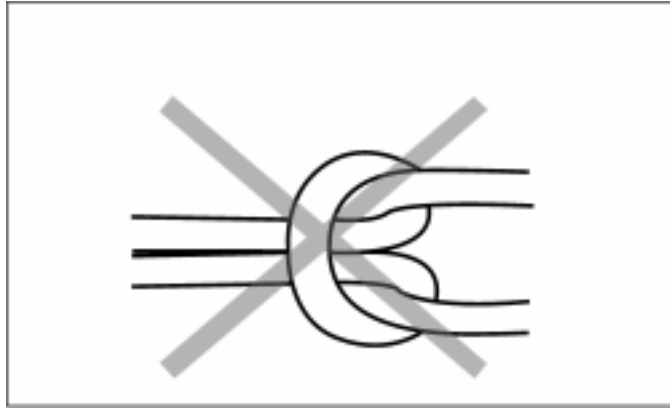

Figure 3–8: The Larks Head Technique for Joining Tape Slings

### 3.31 SAFETY

The following safety points relate to tape:

- a. Many rescuers carry spare slings around their necks when on a task, and it must be recognised that this is a potentially lethal practice. Should the rescuer fall, the loose slings can snag, resulting in a serious or fatal injury.
- b. When slings are carried on operations, they should preferably be carried on the harness, or diagonally around the neck and under one arm.
- c. Knots must be regularly checked for signs of overstrain or loosening, and properly retied or cut and retied where necessary, with minimum tails of 100 mm.
- d. All webbing must be regularly and carefully inspected for signs of damage or abrasion, and where damage is suspected, or serious abrasion has occurred, the tape must be withdrawn from service. Where a sling has been subjected to a severe loading, it may be seriously damaged but the damage may not be obvious. **All such slings must be destroyed.**

#### WARNING NOTE

**HOME SEWN SLINGS ARE TOTALLY UNSAFE AND HAVE NO PLACE IN THE VERTICAL RESCUE ENVIRONMENT.**

- e. Tape must be given the same care as rope. It should be protected from abrasion, contamination, friction heat and shock loading, and inspected before, during and after every use.

### HARNESSES

- 3.32 Personnel working in the vertical environment require the protection and safety of a harness. A properly fitted climbing or rescue harness is essential. Waist ties without leg loops must not be used. A rated locking karabiner or Maillon Rapide must be used for harness attachment, or the rope end must be tied to the harness at the approved point.

### 3.33 INDUSTRIAL SAFETY

Most industrial safety harnesses are unsuitable for vertical rescue. They have no dynamic arrest capability, and most do not have the low front central attachment point essential in many techniques.

### 3.34 MOUNTAINEERING (SIT)

Mountaineering harnesses of the design shown in Figure 3–9 are acceptable for rescue. They consist of a waist belt with a crutch and buttock straps. While a few of these harnesses are adjustable, most are not, and rescuers should exercise care in choosing a harness to ensure it is a correct fit, and is comfortable to wear.

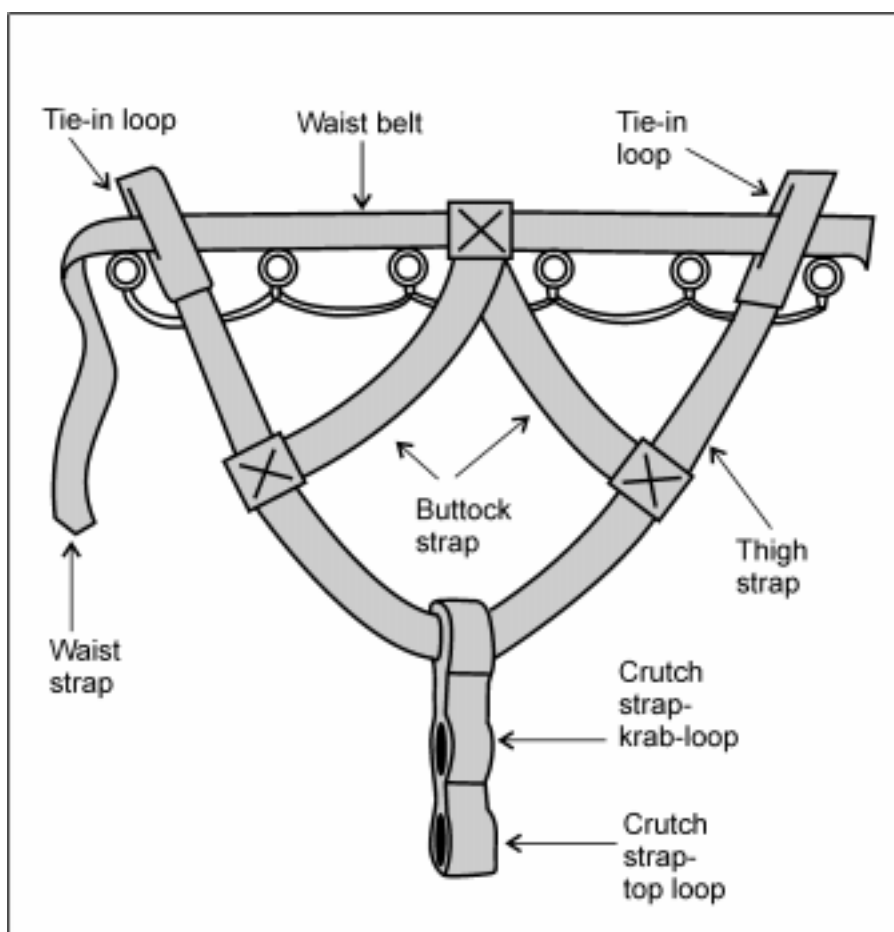

Figure 3–9: Typical Mountaineering Harness

**3.35** Rope end attachment with a mountaineering harness is best accomplished by means of a Figure of Eight Loop, threaded through all three harness loops and then through the harness karabiner as shown in Figure 3–10.

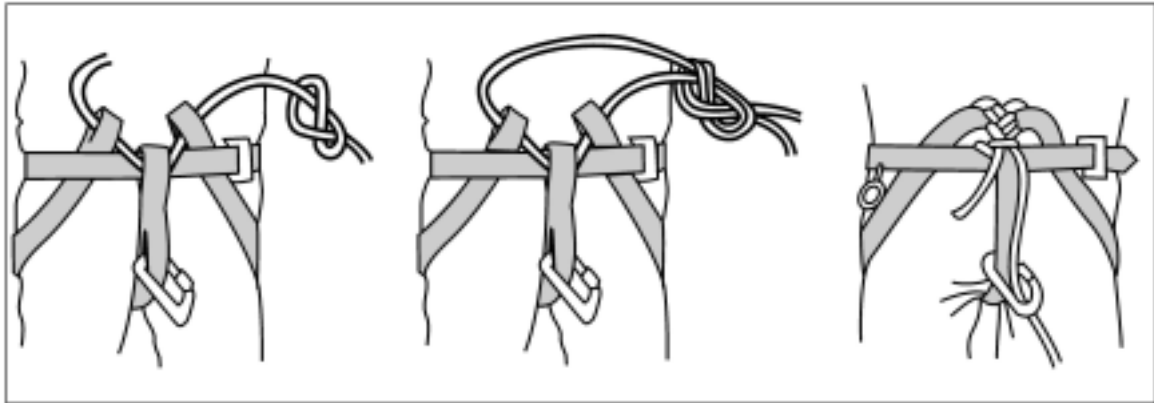

Figure 3–10: Tying into a Mountaineering Harness

### 3.36 FREE STYLE

Free style harnesses, formed from a waist belt and leg loops, and commonly incorporating a 'bum strap' are the most widely used vertical rescue harnesses. (Refer Figure 3–11)

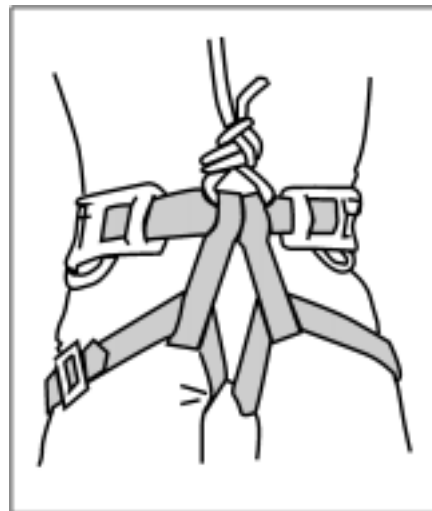

Figure 3–11: A Typical Free Style Harness

- 3.37 The free style is designed as a waist belt and leg loops, thus avoiding the uncomfortable crutch strap integral to the mountaineering harness design. Generally, free style harnesses are more comfortable to sit in for any length of time, and many models are manufactured with an additional 'bum strap' to help support the body.
- 3.38 Almost all harness manufacturers now produce free style harnesses for rescue. As with any other item, a deal of care should be exercised when making a purchase.
- 3.39 New and different harnesses regularly appear on the equipment market. Expert advice should be sought prior to any purchase.

### 3.40 FULL BODY RESCUE

A number of manufacturers produce full body harnesses specifically for vertical rescue. (Figure 3–12)

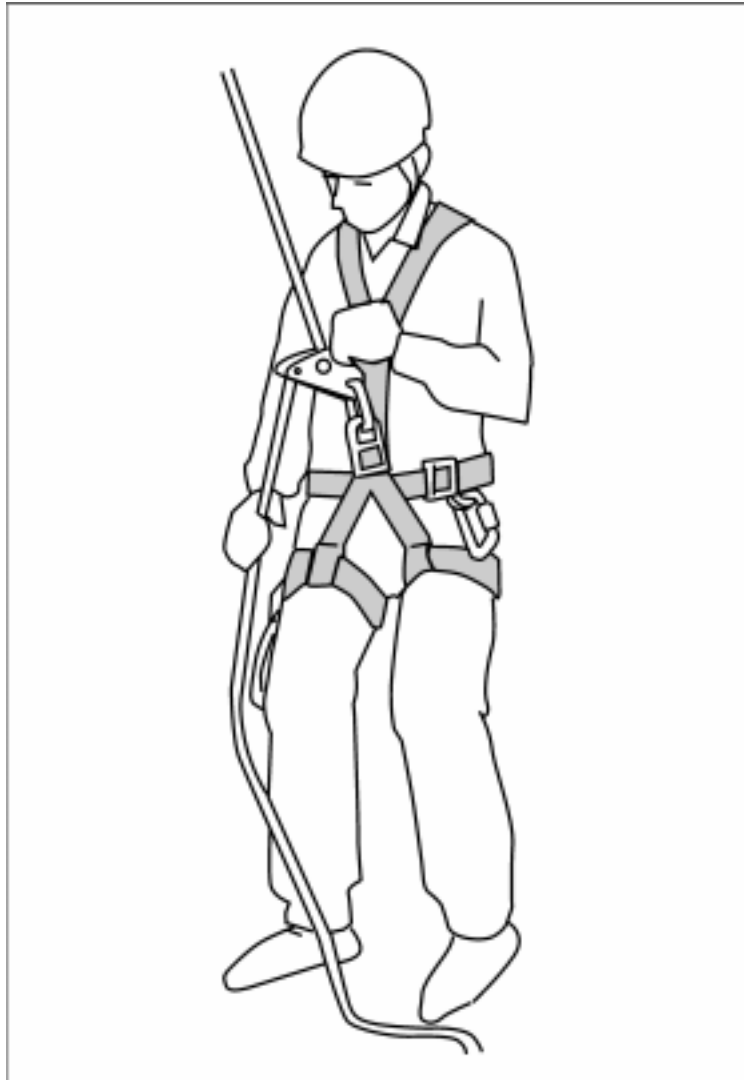

Figure 3–12: A Typical Full Body Harness

**3.41** These harnesses are generally more comfortable to wear, with improved weight distribution, and they provide both low and high attachment points in a single unit.

### 3.42 CHEST

The benefit of a full body harness can be achieved by matching a commercial chest harness (Figure 3–13) with a free style or mountaineering harness.



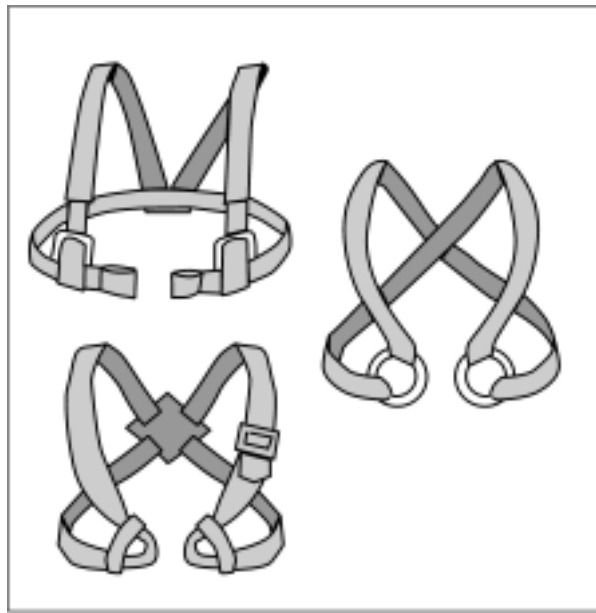

Figure 3–13: Some Styles of Chest Harness

- 3.43** With many harnesses, the strap buckles must be secured by ‘double threading’ as shown in Figure 3–14.

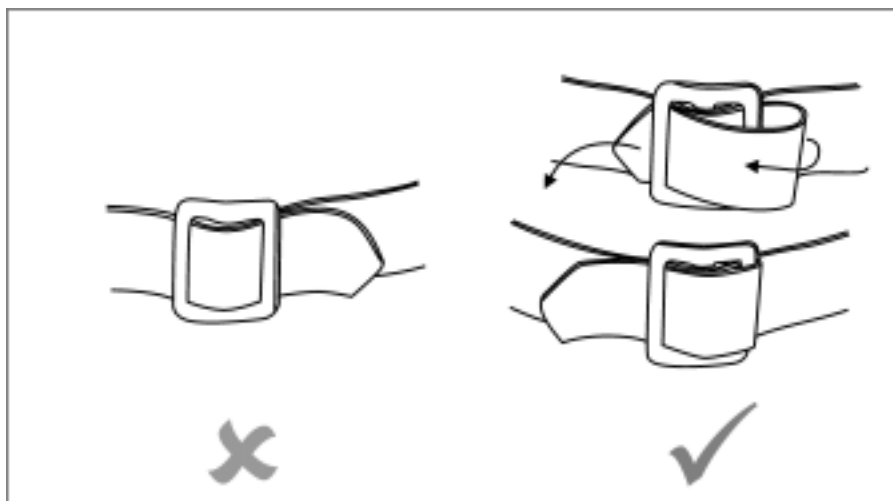

Figure 3–14: Securing Harness Buckles

**3.44 WAIST BELT LOOPS**

Most harnesses are equipped with cord loops around the waist belt. These loops are intended only for carrying spare karabiners and other equipment, and must never be used for any other purpose.

**3.45 HARNESS REPLACEMENT**

The rescue harness is made from sewn tape, and like any other rope or tapes, is subject to abrasion and accidental abuse. Harnesses do reach a stage of wear when they can no longer be fully relied on. At that time, they should be destroyed and replaced.

### 3.46 HARNESS SELECTION

Because of anatomical variations, and the range of different vertical activities, no one harness will suit all rescuers or situations. Harness selection is a matter of trying a range of types in a hanging situation and selecting the most comfortable and suitable.

### 3.47 IMPROVISED HARNESSES

There are a number of methods of forming improvised harnesses out of tape slings. It is essential however that proper instruction is provided in their fitting and use.

**3.48** Improvised rigs can take the form of chest or sit harnesses or a combination of both to form a full body harness. An improvised chest harness can readily be used in lieu of a commercial product.

**3.49** The 'Parisian Baudrier' illustrated in Figure 3–15 is one form of improvised chest harness in common use. A standard tape sling of around 2500 mm circumference is taken around the body in the manner shown in Figure 3–18a, and secured with a Double Sheet Bend (Figure 3–15b).

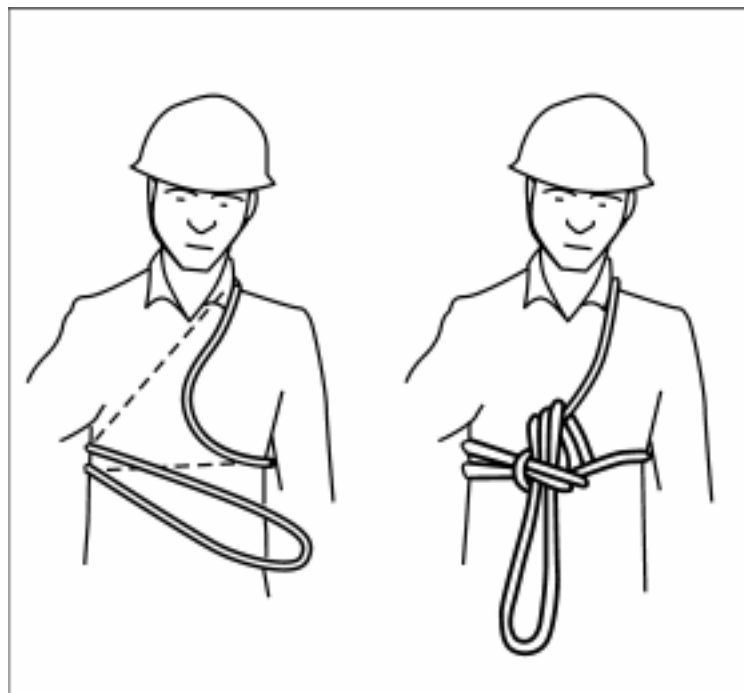

Figure 3–15: Parisian Baudrier



# CHAPTER 4

## KNOTS

### INTRODUCTION

- 4.1 In rescue ropework, the use of a variety of proven knots, properly applied and tied, is essential to the safe and efficient conduct of the activity.
- 4.2 The following chapter outlines the most commonly recommended knots and roping terminology. There are many and varied knots and terms used in ropework. The object here should always be simplicity and ease of operation.

### ROPING TERMINOLOGY

- 4.3 In order to standardise the language and names associated with roping and rope work, terminology as depicted in Figure 4–1 is used.

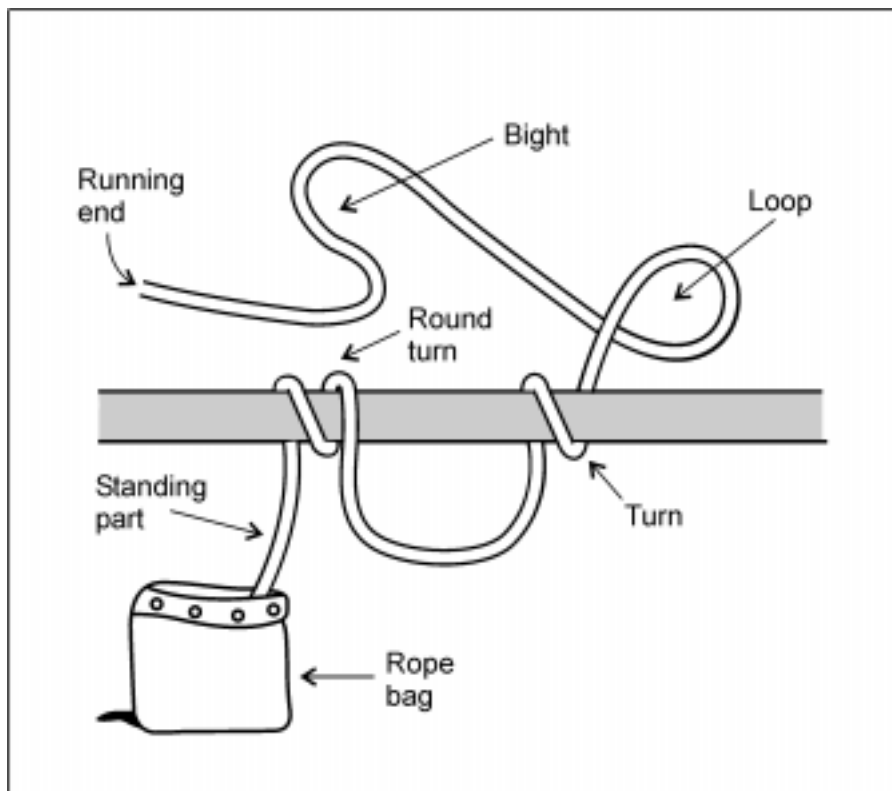

Figure 4–1: Common Roping Terminology

#### 4.4 EXPLANATION OF TERMS

An explanation of the above terms follows:

- a. **Bight**—A bight of rope is a simple bend in which the rope does not cross itself.
- b. **Dressing**—The proper aligning and tensioning of the rope throughout a knot.
- c. **Loop**—A simple bend of rope in which the rope **does** cross itself.
- d. **Round Turn**—One **complete** turn of a rope around a spar or another rope.
- e. **Running End**—The free end of rope which can be used.
- f. **Standing Part**—The part of rope which is fastened.
- g. **Turn**—A partial turn of a rope around a spar or another rope.

#### QUALITIES OF A GOOD KNOT

- 4.5 While knots vary in their specific use, all proven knots have certain characteristics in common:
- a. They are relatively easy to tie.
  - b. It can easily be determined whether or not they are tied correctly.
  - c. Once tied, they remain tied.
  - d. They have minimal effect on rope strength.
  - e. They are relatively easy to untie after loading.

**WARNING NOTE**

**KNOTS MUST BE TIED WITH A MINIMUM TAIL OF 75 MM.**

#### KNOTS AND HOW THEY AFFECT ROPE

- 4.6 Every knot diminishes the strength of rope to some degree, particularly when poorly dressed. The reason for this is that in any sharp bend of a rope (less than four times the diameter of the rope), the filaments on the outside of the bend carry the majority of the load on the rope. The filaments on the inside of the bend will carry very little of the load or none at all.
- 4.7 Knots with sharp bends cause more of a strength loss in rope than do knots which have open bends. Ultimately, the kind of knot, along with other elements of a vertical rescue system, must be taken into consideration when deciding on a safety factor for a rope.

**WARNING NOTE**

**AN IMPROPERLY TIED KNOT, OR THE INCORRECT APPLICATION OF A KNOT COULD RESULT IN SERIOUS INJURY OR DEATH.**

#### 4.8 THUMB OR OVERHAND KNOT

This is the basis of many knots.



Figure 4–2: Thumb (or Overhand) Knot

#### 4.9 FIGURE OF EIGHT KNOT

The Figure of Eight knot can be used as a stopper knot, tied a minimum of one metre from the bottom end of a rope to prevent a person from abseiling off the end, or at the top end of rope to prevent it from accidentally slipping through equipment.

4.10 The Figure of Eight Knot is the foundation of the Figure of Eight on the Bight and the Figure of Eight Loop.

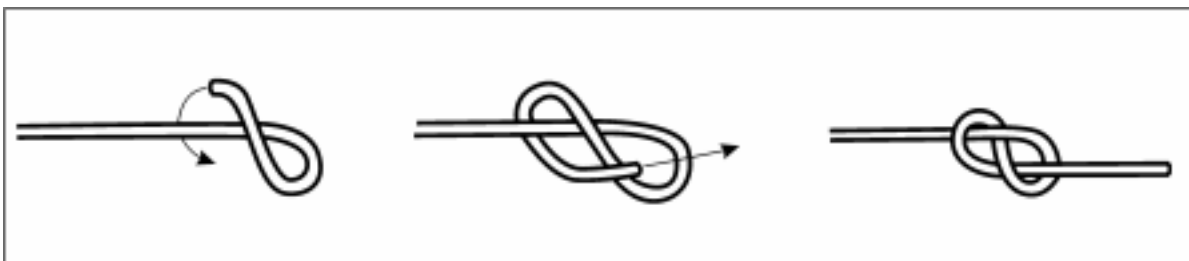

Figure 4–3: Figure of Eight Knot

#### WARNING NOTE

**AS WITH ALL KNOTS, FIGURE OF EIGHT KNOTS SHOULD BE DRESSED (THE ROPE ALIGNED AND UNCROSSED) AND COMPACTED (ALL ENDS PULLED DOWN SO THAT THE KNOT IS COMPACT). THIS ENSURES THAT THE KNOT HAS ITS GREATEST HOLDING POWER, WHILE REDUCING THE ROPE STRENGTH AS LITTLE AS POSSIBLE.**

#### 4.11 FIGURE OF EIGHT ON THE BIGHT

This knot is used to form a secure loop in a rope for clipping into such items as karabiners. The advantages of the Figure of Eight on the Bight are that it:

- a. is easy to identify,
- b. has a relatively low effect on rope strength, and
- c. is easy to untie after pressure is applied.

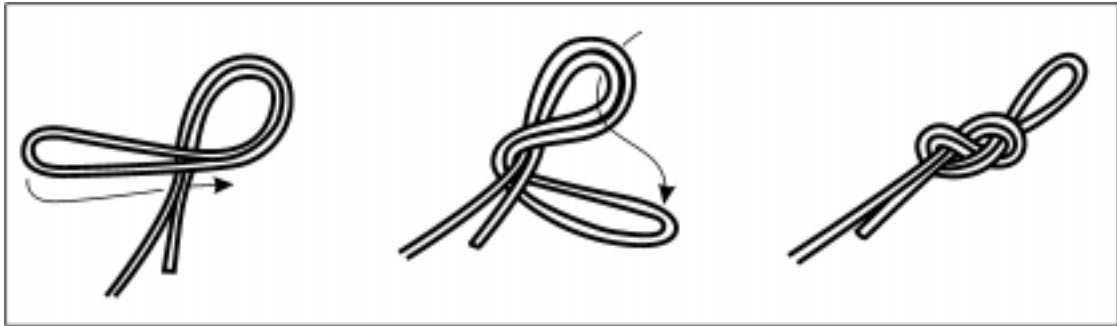

Figure 4–4: Figure of Eight on the Bight

#### 4.12 FIGURE OF EIGHT LOOP

The Figure of Eight Loop (or follow through) is a versatile knot. It can be used to form a loop at the end of a rope in situations where a Figure of Eight on the Bight cannot be tied. An example would be a situation such as a tall tree, where a Figure of Eight on the Bight cannot be dropped **over** the anchor, and the Figure of Eight Loop can easily be tied **around** it.

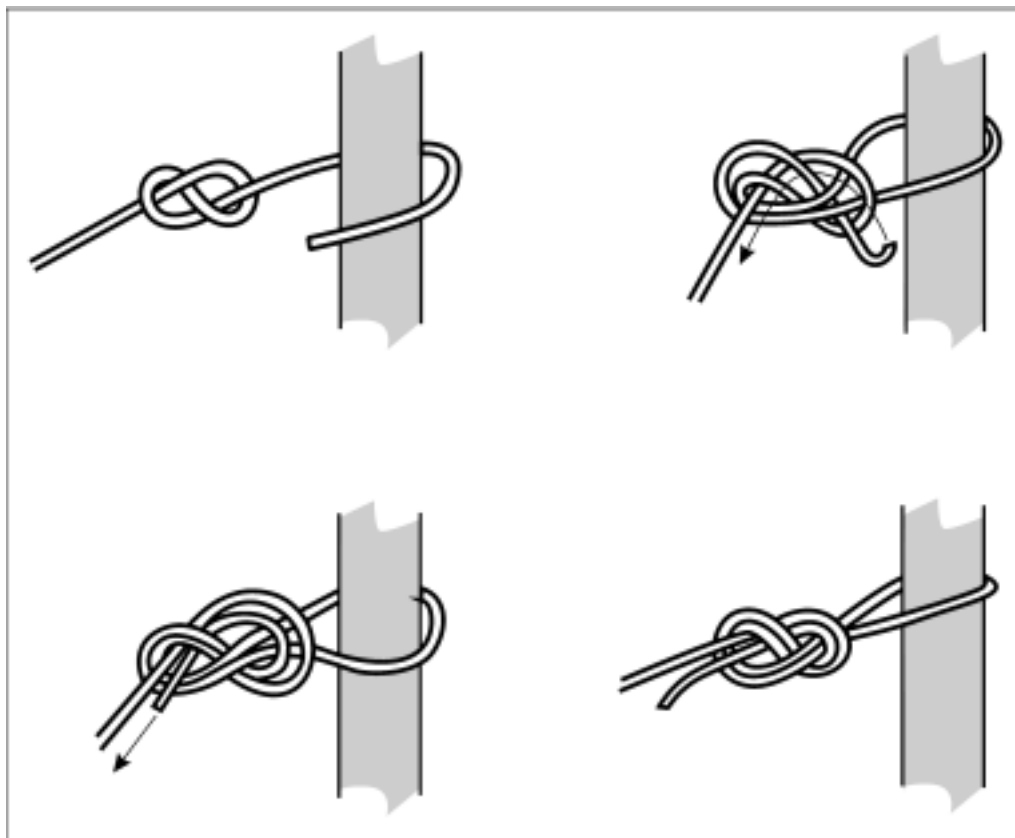

Figure 4–5: Figure of Eight Loop

#### 4.13 TYING THE FIGURE OF EIGHT LOOP

Suggestions for tying the Figure of Eight Loop are as follows:

- a. Note that the knot begins with the tying of a Figure of Eight knot as a foundation, well back from the end of the rope.
- b. After the Figure of Eight is tied, the end of rope is passed around the anchor point, and then taken back through parallel to the first knot. Every contour of the first knot is followed, with both rope ends going in the same direction.

#### WARNING NOTE

**THE FIGURE OF EIGHT ON THE BIGHT AND THE FIGURE OF EIGHT LOOP ARE NOT SAFE WHEN SUBJECTED TO A THREE-WAY LOADING. IN ALL CASES WHERE A SECURE LOOP IS REQUIRED IN THE MIDDLE OF A ROPE, THE ALPINE BUTTERFLY SHOULD BE USED.**



#### 4.14 ALPINE BUTTERFLY

The Alpine Butterfly excels as a mid-rope knot to form a fixed loop with two or three-direction loading capability. It is very easy to tie and untie after loading.

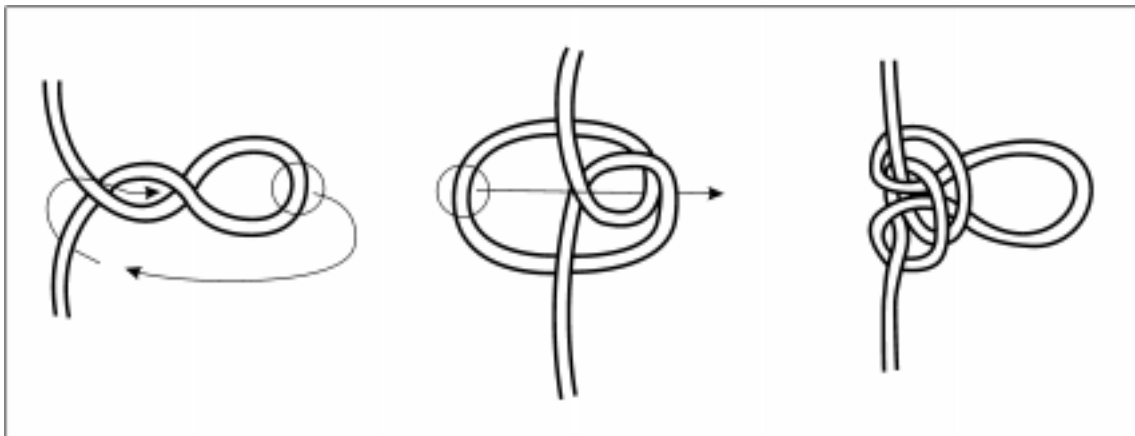

Figure 4–6: Alpine Butterfly

#### 4.15 CLOVE HITCH

The Clove Hitch can serve as an adjustable belay knot when formed in the middle of a rope. It has the advantage of being easy to tie and to adjust.

##### WARNING NOTE

**THE CLOVE HITCH MUST NOT BE USED AS A FINAL ANCHOR KNOT.**

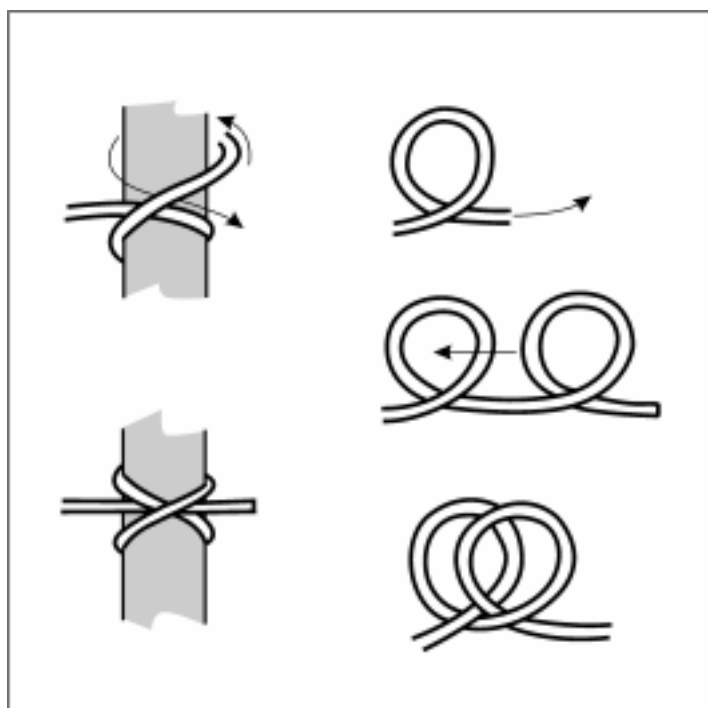

Figure 4–7: Clove Hitch

#### 4.16 DOUBLE FISHERMANS KNOT

This knot is used for joining ropes of equal or unequal thickness, but it has the disadvantage of being hard to untie after loading. It can be used for joining cord to form a Prusik loop.

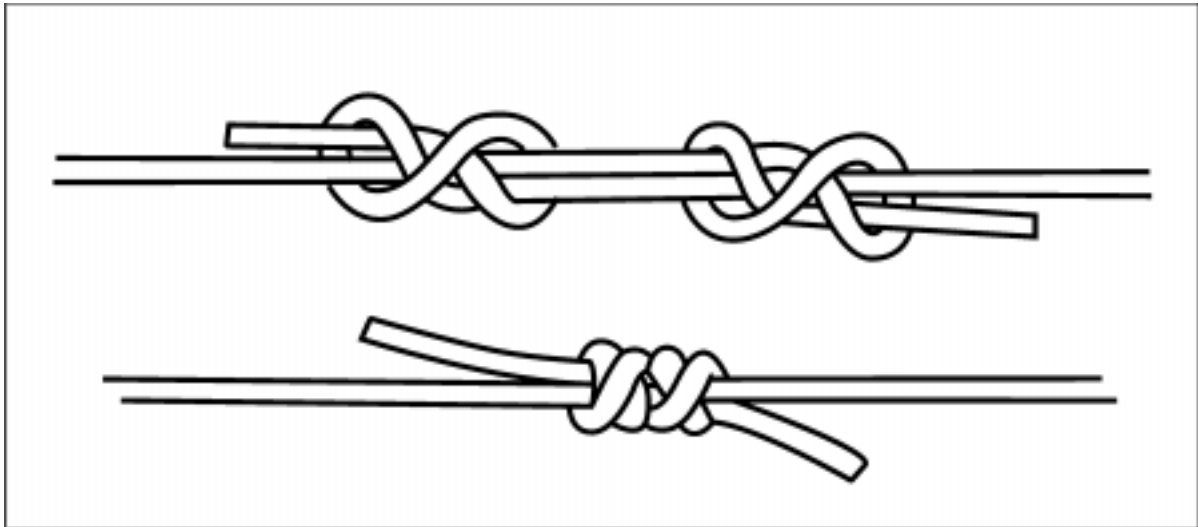

Figure 4–8: Double Fishermans Knot

#### 4.17 ROUND TURN AND TWO HALF HITCHES

The Round Turn and Two Half Hitches can be used for tying a rope to an anchor point. It has the advantages that it will not over-tighten, it is easy to adjust, and it imposes minimal stress on the rope. When tied in synthetic rope, this knot must be carefully monitored.

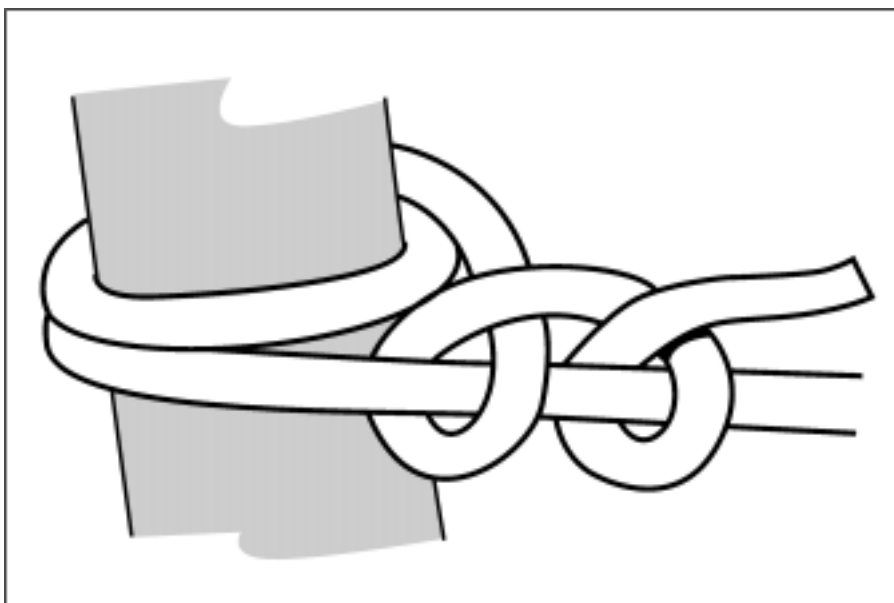

Figure 4–9: Round Turn and Two Half Hitches

#### 4.18 TAPE KNOT

The only knot suitable for joining tapes to form slings is the Tape Knot. (Figure 4–10)

##### WARNING NOTE

**THE TAPE KNOT MUST NOT BE USED WITH ROPE. BECAUSE OF THE FLAT NATURE OF TAPE, IT HAS THE QUALITY OF CONTOURING OVER ITSELF. ROPE DOES NOT HAVE THIS QUALITY, AND A TAPE KNOT TIED IN ROPE MAY EASILY COME UNDONE.**

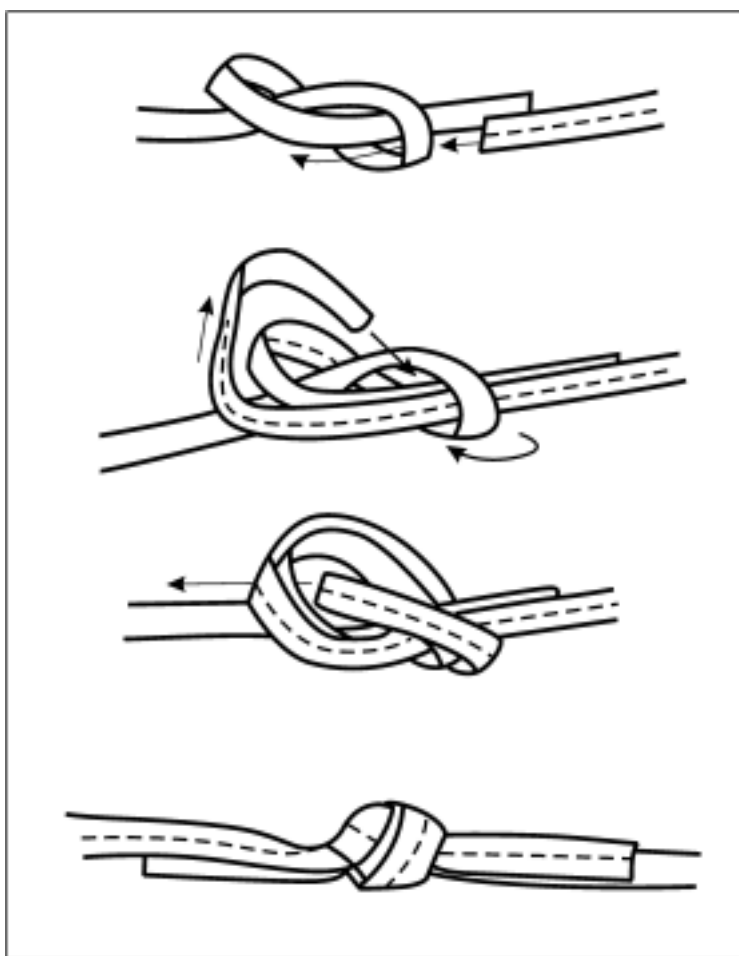

Figure 4–10: Tape Knot

#### 4.19 TAPE KNOT SAFETY

The following safety points for the Tape Knot must be observed:

- a. Always leave at least 100 mm of tape in the ends of Tape Knots **after they are tied and pulled tight**. Although it contours well in a Tape Knot, webbing tends to be slippery, thus ends that are too short tend to slip through under load.
- b. Be certain that the tape follows flat through the knot. A twist in the tape inside the knot will allow the knot to slip at relatively low loads.
- c. **Inspect** Tape Knots frequently.

## 4.20 PRUSIK KNOT

The Prusik Knot is a means of attaching a cord loop to a rope. Figure 4–11[b] shows a two wrap Prusik normally sufficient for Prusiking or for light loads. The three wrap Prusik shown in Figure 4–11[c] is normally used for rescue attachments. Figure 4–11

### WARNING NOTE

**THE PRUSIK KNOT SHOULD NEVER BE SUBJECTED TO A SHOCK LOAD AS IT MAY SLIP.**

**THE PRUSIK CORD MUST BE AT LEAST 3 MM SMALLER IN DIAMETER THAN THE MAIN ROPE TO PROVIDE AN EFFECTIVE CAMMING ACTION.**

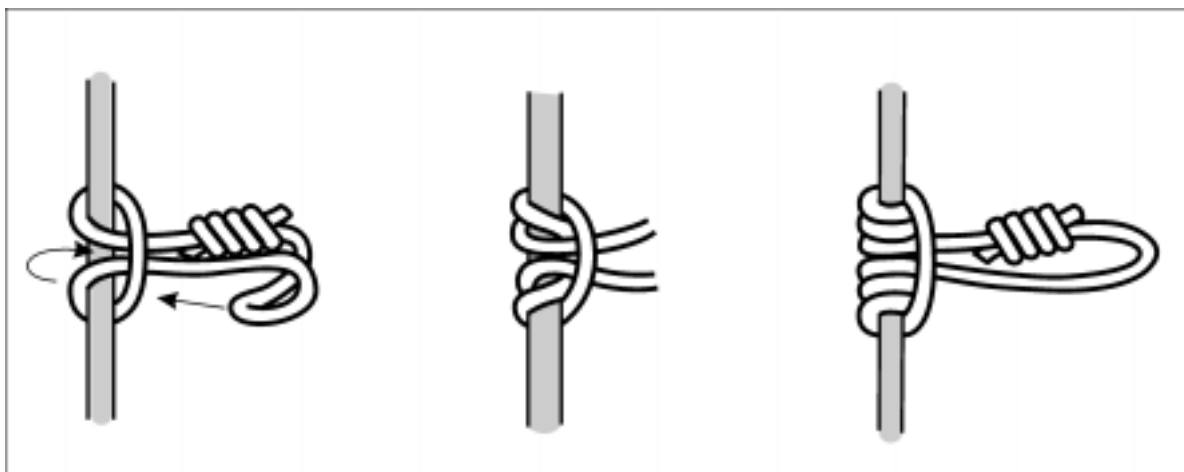

Figure 4–11: Prusik Knot

#### 4.21 KLEMHEIST KNOT

The Klemheist Knot has the same uses as the Prusik Knot, but has the added advantage in that it can be formed with tape on a fixed rope.

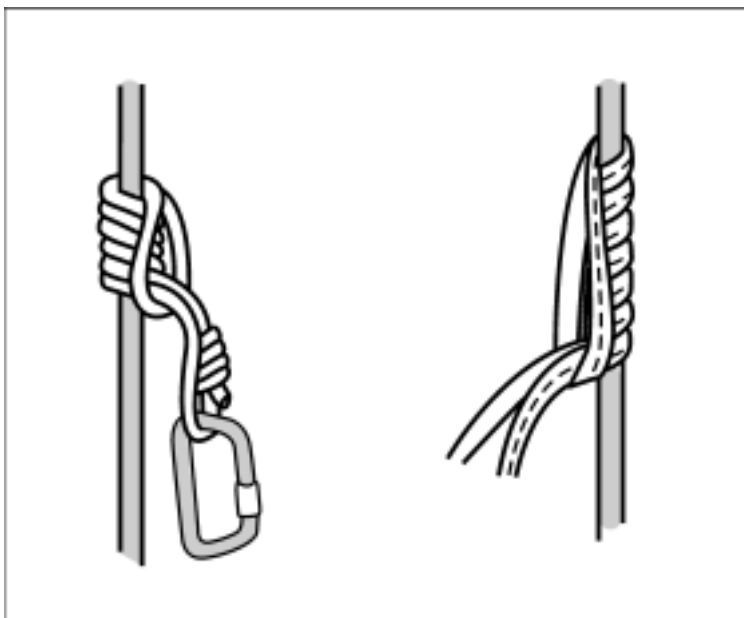

Figure 4–12: Klemheist Knot

#### 4.22 BACHMANN KNOT

The Bachmann Knot has the same applications as the Prusik Knot, but the inclusion of a karabiner provides a handle for ease of movement of the knot on the fixed rope.

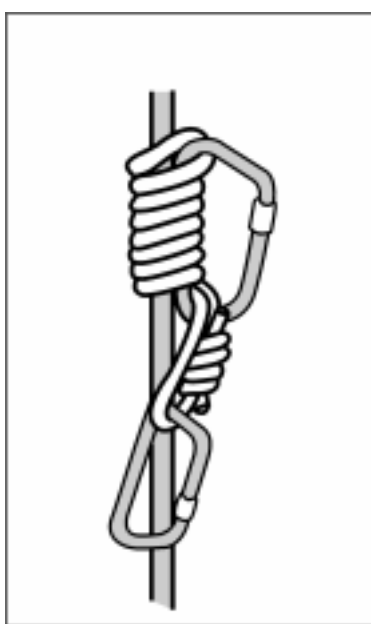

Figure 4–13: Bachmann Knot

## KNOT STRENGTHS

**4.23** The tying of any knot in a rope will reduce the rated strength of the rope by up to one third (1/3). Care must therefore be exercised in selecting the correct knot for the task in hand (refer paragraph 4.7).

### 4.24 BREAKING STRAINS

The following chart shows the **approximate** residual breaking strains of new rope in which rescue knots have been formed:

Thumb (Overhand) Knot	45–55%
Figure of Eight Knot	55–65%
Figure of Eight on the Bight	60–70%
Figure of Eight Loop	60–70%
Alpine Butterfly	65–70%
Clove Hitch	60–70%
Double Fishermans Knot	60–70%
Round Turn and Two Half Hitches	60–65%
Tape Knot	60–65%



# CHAPTER 5

## HARDWARE

### INTRODUCTION

- 5.1 Rope, tape and other software are critical to the vertical rescue system. Another vital link in the system is a category of equipment known as **hardware**. This category includes a variety of equipment, usually constructed of metal, that performs specific functions in the vertical environment.

#### WARNING NOTE

**HOME-MADE EQUIPMENT HAS NO PLACE IN VERTICAL RESCUE.**

### KARABINERS

- 5.2 Known also as krabs or 'biners', these are the most common item of hardware in vertical rescue. They are normally a 'D' or modified 'D' shaped metal link, having a spring loaded opening section (the gate) in one of the long sides.

#### 5.3 GATES

The gate allows ropes and slings to be clipped into the karabiner for attachment purposes. Karabiners are manufactured from either high tensile steel or alloy, and may have either a plain opening gate, or one fitted with a screw locking device which prevents the gate from accidental opening. Consequently, karabiners are referred to as either **snaplincs** or **screwgates**.

#### 5.4 RATED STRENGTH STAMP

Most manufacturers stamp the rated strength of the karabiner into the metal for easy reference.

#### 5.5 CARE IN USE

As these devices are made of quality steel or alloys, care should be taken not to drop them or knock them on hard surfaces. Small stress points can be introduced into the metal which may then cause deterioration of the device. Figure 5-1 shows the basic parts of a screwgate karabiner.

#### 5.6 RESCUE USE

Rescue karabiners should be of screwgate pattern with a minimum rated strength of 2500 Kg. **Snaplinc style karabiners are not recommended for rescue.** It is recommended that all rescue 'team karabiners' be steel screwgates as they will generally better withstand hard usage. Alloy screwgates should be used for personal applications except where weight is a major consideration.



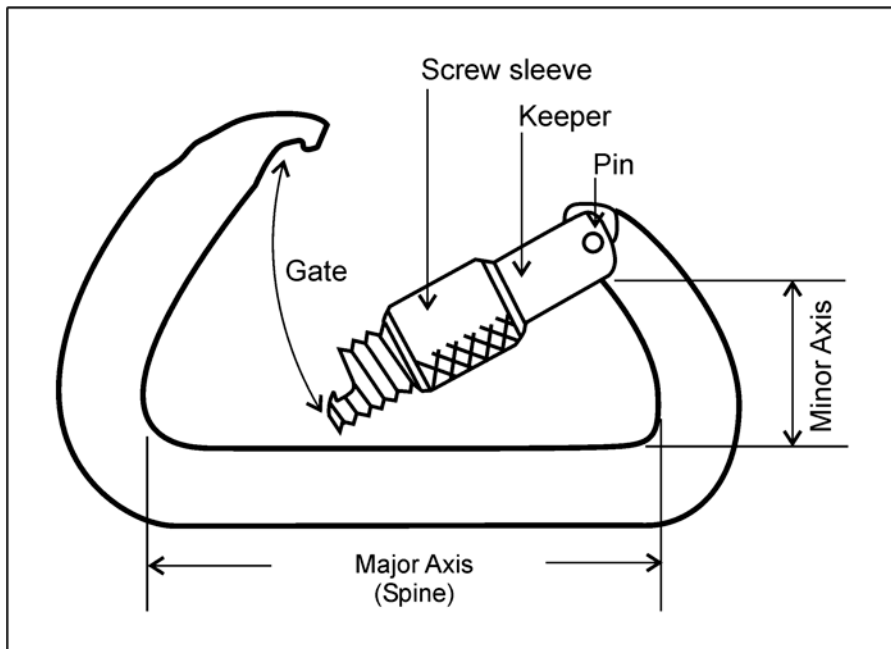

Figure 5–1: The Karabiner

## 5.7 GATE OPENINGS

There are considerable differences in the widths of karabiner gate openings. For some activities, the gate opening will have to be larger than normal. A rescue karabiner may have to be clipped over a rescue litter rail of around 25 mm in diameter, and so must be selected with this gate size in mind.

## ACCIDENTAL GATE OPENING

- 5.8** The main job of a karabiner is to maintain its link with the other elements of the vertical rescue system. To do this, the karabiner gate must remain securely closed. If it does not, then the connecting elements will come apart and the system will fail.
- 5.9** There are several ways in which karabiner gates may come open accidentally, as shown in Figures 5–2 and 5–3

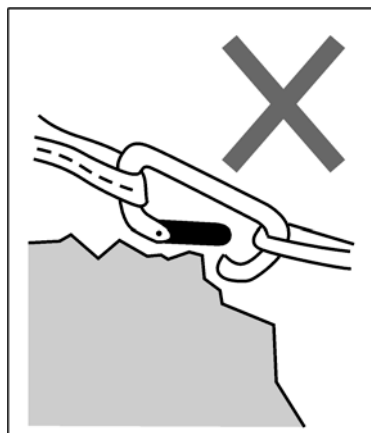

Figure 5–2: Accidental Gate Opening

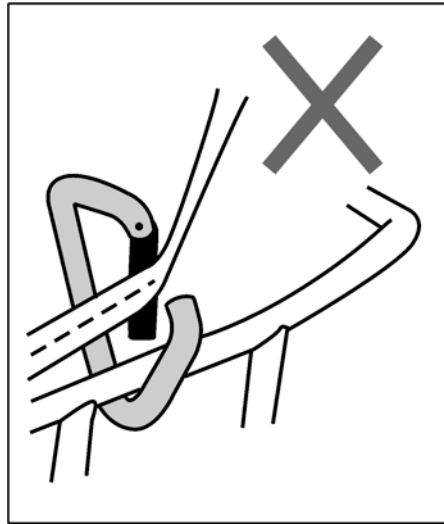

Figure 5–3: Accidental Gate Opening

#### 5.10 AVOIDING GATE OPENING

As accidental gate opening is a particular feature of plain gate or snaplink karabiners, it follows that this problem is solved by the use of only locking gate karabiners in rescue.

- 5.11 Where only snaplink (non-locking) karabiners are available, then two karabiners should be used in a **reversed and opposed** attitude as shown in Figure 5–4.

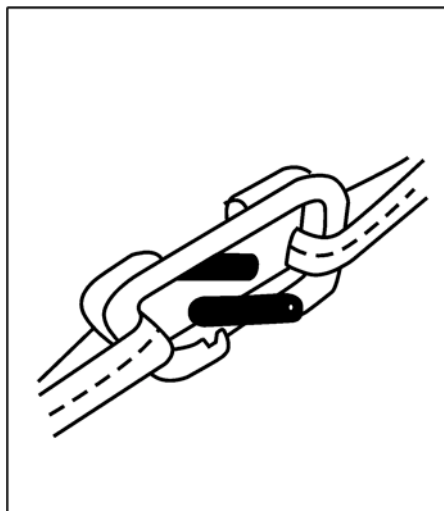

Figure 5–4: Reversed and Opposed Snaplinks

#### 5.12 LOCKING KARABINERS

Though specific designs will vary depending on the manufacturer, locking karabiners usually fall into the following categories:

- A locking sleeve moves on screw threads over the nose of the karabiner to ensure closure.
- A sleeve turns around a pin on the gate to move up and over the nose.

- c. A spring-loaded sleeve makes a quarter turn to unlock from the nose of the karabiner. This style, commonly known as a **Twistlock** is convenient to use, but can come open under some circumstances. It therefore should not be used for rescue purposes.
- d. A sleeve moves downwards over the gate hinge to hold the gate locked.

**5.13** Of all of the types of locking karabiners, the screwgate style described in [a] above tends to be the strongest and most secure for rescue purposes.

#### **5.14 ADDITIONAL CONCERNS WITH LOCKING KARABINERS**

Any karabiner which regularly becomes unlocked without apparent reason must be withdrawn from service. Karabiners are designed to be locked only to finger tightness. In their concern for safety, and in some anxiety, some people will tend to over-tighten a karabiner gate, and then be unable to unlock it. This most commonly occurs when the gate is tightened while the karabiner is under load, and unlocking it is readily accomplished by again subjecting it to a load.

#### **WARNING NOTE**

**ALL EQUIPMENT USED IN VERTICAL RESCUE IS DESIGNED TO BE USED IN A SPECIFIC MANNER OF FUNCTION. THIS IS PARTICULARLY TRUE OF KARABINERS. ANY EQUIPMENT NOT USED IN THE DESIGNED MANNER MAY FAIL, RESULTING IN INJURY OR DEATH.**

#### **5.15 KARABINER USAGE AND SAFETY**

Karabiners are designed to be loaded along the major axis or spine as shown in Figure 5–5. The gate is the weakest point of a karabiner, and any side loading such as is shown in Figure 5–6 places an unnatural force on the karabiner, severely reduces its strength, and may cause it to fail.

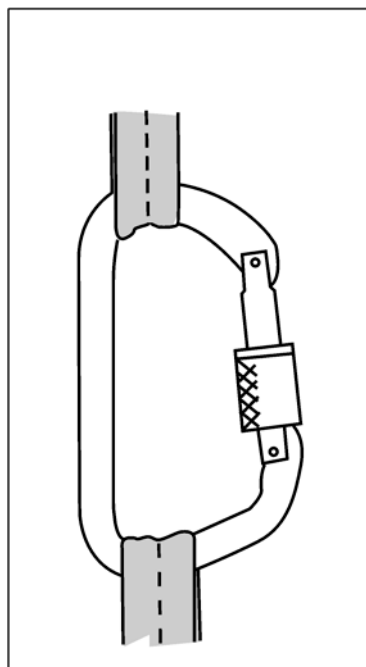

Figure 5–5: Karabiner Correct

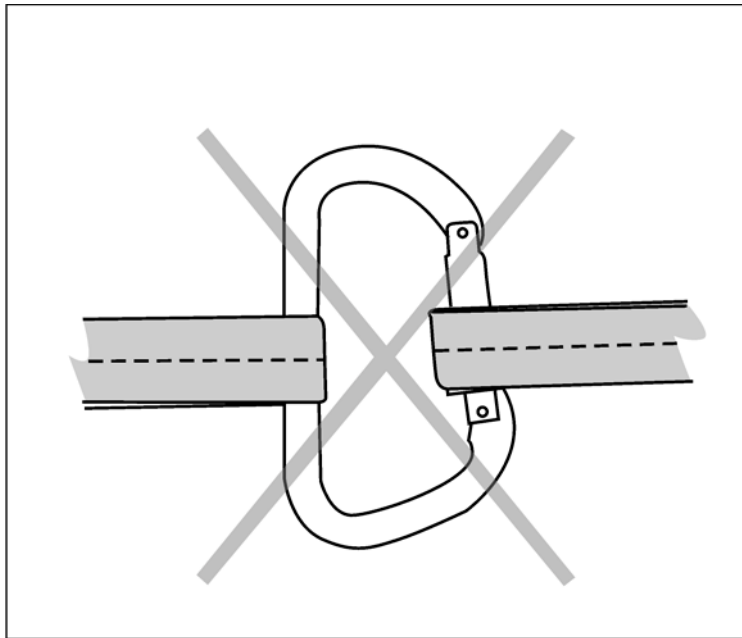

Figure 5–6: Karabiner Incorrect

- 5.16** With some karabiner designs, vibration can cause the gate locking sleeve to unscrew. Karabiners should always be used in a manner which will ensure that gravity will keep the sleeve in place. Whatever the type of karabiner in use, it is the rescuers responsibility to monitor it at all times to ensure that the gate remains closed.

**WARNING NOTE**

**MAXIMUM STRENGTH IS ONLY ACHIEVED WITH THE KARABINER GATE LOCKED. KARABINERS MUST NOT BE USED UNLESS THE GATE IS CLOSED AND LOCKED.**

## **MAILLONS**

- 5.17** Maillons are alternatively known as ‘quicklinks’ or ‘screwlinks’, and are used for many rescue tasks. As can be seen from Figure 5–7, they come in a range of sizes and shapes, with rated strains for the steel versions as high as 6000 kg. Like karabiners, they are produced in steel or special alloys, and their high strength, spanner lockable sleeve and absence of a weakening gate make them suitable for a range of techniques. The triangular ‘delta’ maillons are particularly useful where a three-way loading may be imposed, as with a stretcher bridle.

### **5.18 RESCUE REQUIREMENTS**

It is recommended that only those links marked with the name ‘Maillon Rapide’ and with a rated strength stamped on the device be used for rescue.

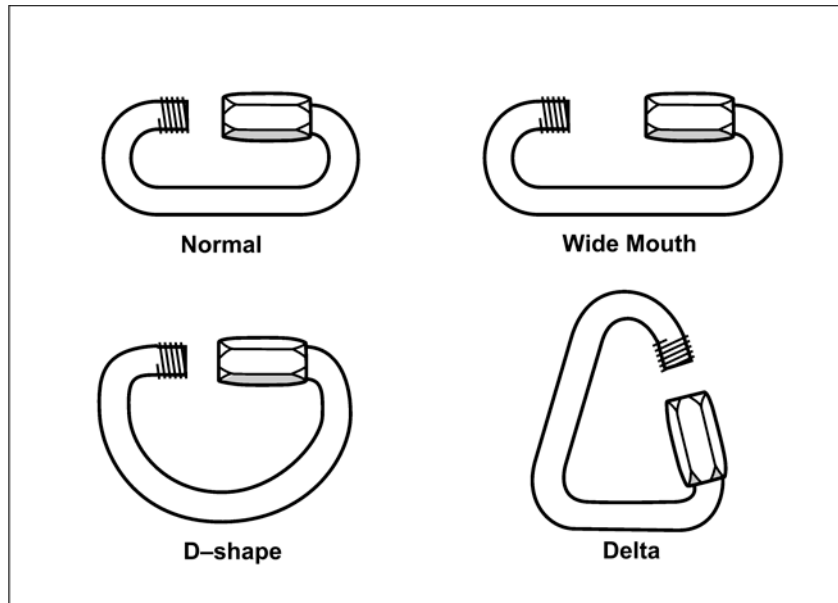

Figure 5-7: Maillons

## BELAY PLATES

- 5.19** The belay plate, often referred to as the Sticht plate, has proven to be a safe form of belay to provide protection for a single rescuer moving in a dangerous area.

### WARNING NOTE

**BELAY PLATES ARE NOT SAFE FOR ABSEILING AS THERE IS INSUFFICIENT MASS OF METAL TO ABSORB FRICTION HEAT.**

### 5.20 FITTING

A bight of rope is passed through the slot in the belay plate and clipped into the anchor attachment karabiner as shown in Figure 5-8. A small keeper cord should be attached to the hole in the plate and looped inside the attachment karabiner. During rope movement, this will prevent the plate from sliding out of reach.

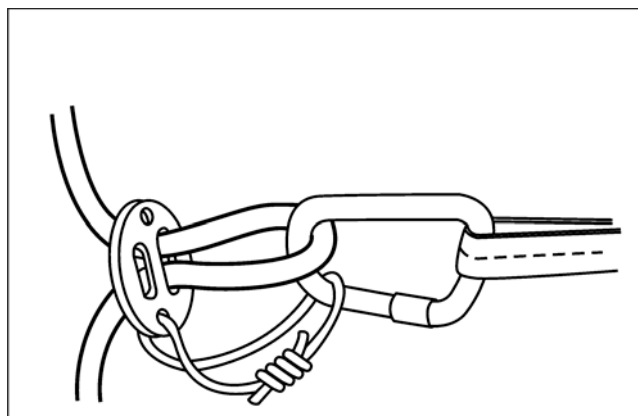

Figure 5-8: Belay Plate

## 5.21 OPERATION

With minimal effort, the rope will run freely through the belay plate, unless the plate is jammed against the karabiner. When held and operated correctly, a falling load automatically causes the plate to jam against the karabiner, thus trapping the rope.

- 5.22 One version of belay plate is fitted with a spring to maintain the proper distance between the plate and its karabiner, allowing the rope to pay out more freely. To initiate a belay requires determined effort to snug the spring-loaded plate tight against the karabiner.

## CAM BELAY DEVICES

- 5.23 The Petzl GriGri (Figure 5–9) and the SRTE No Worries (Figure 5–10) are two of the most commonly used cam-based belay and positioning devices. Each of these systems has very specific requirements for reeving the rope and setting up the device, and the manufacturers guidelines must be followed closely.

### 5.24 GRIGRI

The GriGri is designed for single person belay systems, and for positioning a rescuer on any unstable surface. Rope can be paid out or taken in through the device, and in the event of a fall, the changing attitude of the active rope causes the cam to grip on the rope. The handle can be used to unlock the cam and continue with the belaying procedure. The device is designed for use with 10–11 mm rope.

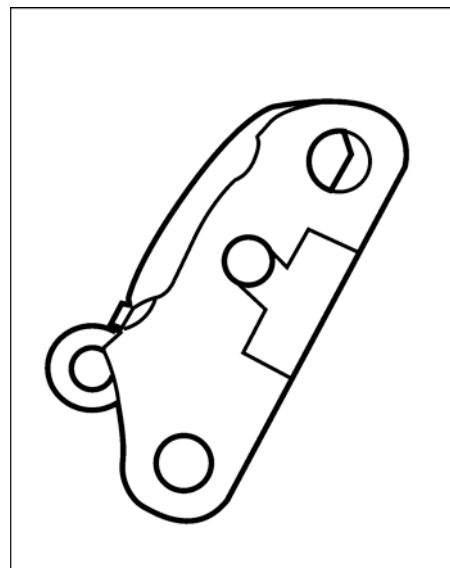

Figure 5–9: Petzl GriGri

### 5.25 NO WORRIES

The SRTE No Worries comes in several models, each with distinctive features, and capable of managing rope up to 13 mm. These devices are heavy duty single person belay systems, which can also be used for positioning or lowering operations, and for abseiling. When used for abseiling, they provide for adjustable fixed rate of descent.

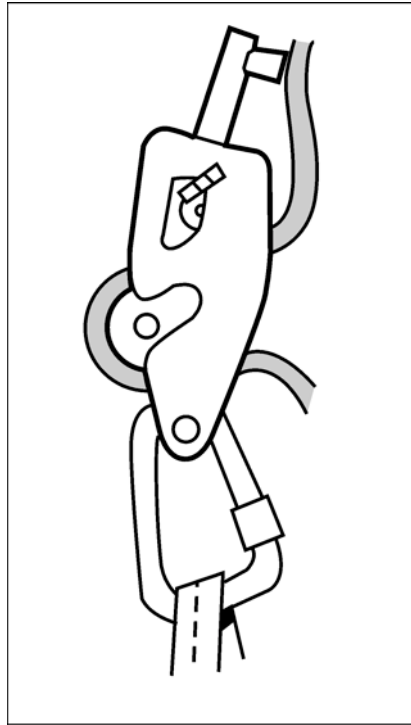

Figure 5–10: SRTE No Worries

## DESCENDERS

**5.26** More detailed notes on the use of descenders is included in Chapter 9—Descent. The following paragraphs provide a review of the equipment used in abseiling and lowering.

### 5.27 DEFINITION

Descenders are friction devices which are placed on the rope and attached to a rescuer to allow them to descend the rope at a controlled speed. They can also be used to lower people or equipment.

### 5.28 COMMON TYPES

The descenders most commonly used in rescue are the figure 8 and the in-line variable friction device. These are detailed in paragraphs 5.29 and 5.30 respectively.

### 5.29 FIGURE 8 DESCENDERS

Characteristics are as follows:

- a. **Description**—These descenders are **one person** abseil devices roughly in the shape of an ‘8’, but with rings of unequal size. (Figure 5–11) The smaller ring, or lower one when in use, is clipped to the harness by means of a screwgate karabiner. The larger ring is the one through which the rope passes to create friction. It should be noted that all figure 8 descenders will twist and cause kinks in the rope.
- b. **Variations**—Some figure 8 descenders are manufactured with projecting ‘ears’ or ‘horns’ (Figure 5–12) to prevent the rope slipping and jamming as shown in Figure 5–13 due to incorrect rigging and technique.

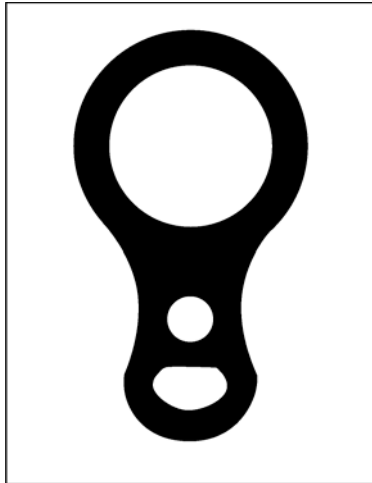

Figure 5–11: Figure 8 Descender

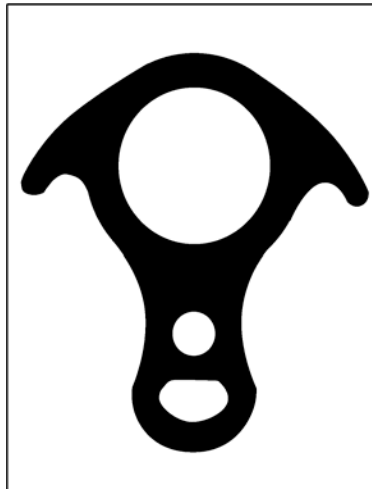

Figure 5–12: Figure 8 Descender with 'Ears'

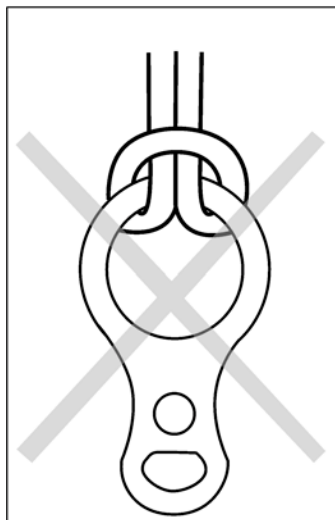

Figure 5–13: Incorrect Rigging



### 5.30 IN-LINE VARIABLE FRICTION DESCENDERS

Usage and examples are described below:

- a. **Applications**—In-line variable friction descenders offer a great deal of control and the ability to vary the amount of friction. They can be used for very long descents, and can sustain loads of more than one person. These devices do not kink the rope, but they are not suitable for belaying.
- b. **Preparation**—The rope is reeved between the pegs or bars in accordance with the manufacturers specifications, and the sliding gates are locked for security. The device is secured to the harness or anchor by means of a screwgate karabiner. The amount of friction is varied by increasing or decreasing the number of bars/pegs around which the rope is reeved.
- c. **Whaletail and Goldtail Descenders**—The 'Rescue Goldtail' and 'Rescue Whaletail' are large aluminium block descenders which provide good heat dissipation and in-line friction control. Both devices have rated strengths in excess of 2500 kg and both are suitable for abseiling and lowering operations.

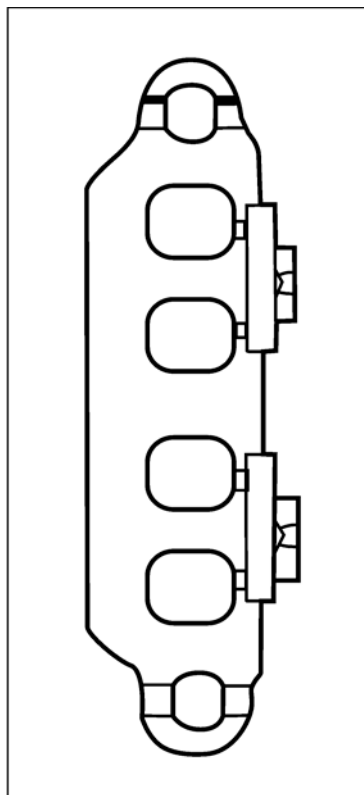

Figure 5–14: Rescue Goldtail

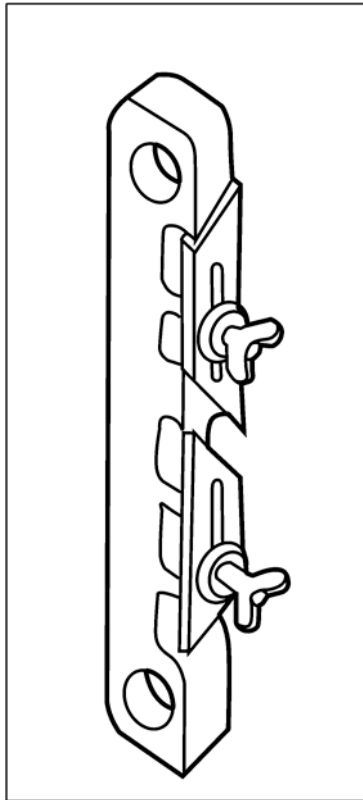

Figure 5–15: Rescue Whaletail

### 5.31 RAPPEL RACK

The common rappel rack consists of two primary elements:

- a. An inverted 'U' shaped frame, one leg of which is longer than the other. The end of the longer leg has an eye through which a karabiner can be connected.
- b. A series of bars, each with a hole drilled at one end so that they can slide freely on the short side of the frame. On their other ends, the bars are notched so that the end of the bar will clip into the long side of the frame. The rope is reeved through the bars, and when under tension, will hold the bars in place on the frame. (Figure 5–16). In the most common configuration, the rack is arranged with a 25 mm diameter grooved 'top bar' at the top to keep the rope in the middle of the bars as it runs through the rack. Usually, five aluminium 19 mm bars fill out the remainder of the rack.

### 5.32 RESCUE RAPPEL RACKS

Some rappel racks have rated strengths of 700 kg or less. 'Rescue' racks can be obtained with much higher rated strengths, and with the ability to accept larger diameter ropes.

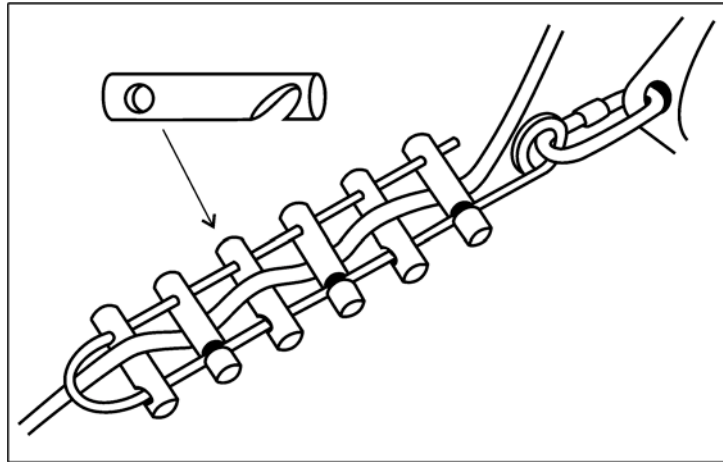

Figure 5–16: Rappel Rack Rigged for Abseiling

### 5.33 I'D SELF-BRAKING DESCENDER

The Petzl I'D self-braking device is a fairly efficient descender, which can also be used safely as a belay device. The descender (Figure 5–17) is similar in camming concept to the GriGri and No Worries, and provides a handle with which to control the amount of friction required, or to lock onto the rope.

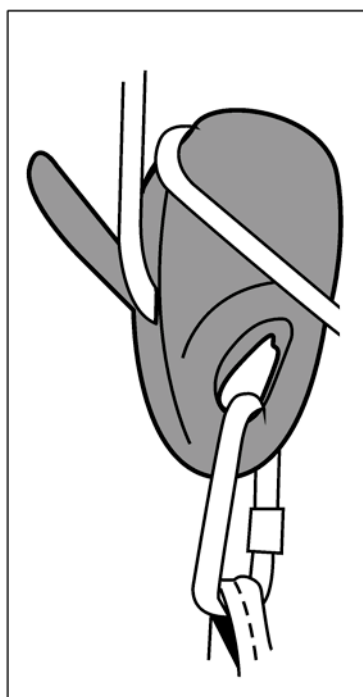

Figure 5–17: I'D Self-Braking Descender

## ASCENDERS

**5.34** The traditional method of rope ascent using a pair of cord slings and Prusik knots works well, and every rescuer should be able to ascend in this way. For a rescue operation mechanical ascenders are recommended as they can also be used for a wide range of rope attachment purposes.

### 5.35 SPRING ASCENDERS

Mechanical ascenders work by means of a cam which jams the rope so that the ascender will slide up the rope but not down. Most rely on a spring to keep the cam in contact with the rope, and small teeth on the cam to give positive grip. Once the cam 'bites', it will only hold more strongly as the load increases, so a strong spring is not necessary.

### 5.36 CAM ASCENDERS

Other ascender designs use the load to activate the cam via a lever. This gives the advantage that teeth are of minor importance so the device has a good grip even on wet or muddy ropes. A second advantage is that cam ascenders have very little rope drag. They move up the rope more easily and last longer due to reduced wear.

### 5.37 SELECTION CRITERIA

The choice of ascenders should be made in terms of suitability for an ascent system, ease of use, simple loading of the rope, cam open setting and overall weight.

**5.38** Many ascenders are made with an integral handle in left and right hand versions to allow for comfort of use. Short, compact ascenders can be used for virtually any application. Some are specially designed for use as chest mounted ascenders. Others are less specific and can be mounted anywhere in an ascent rig.

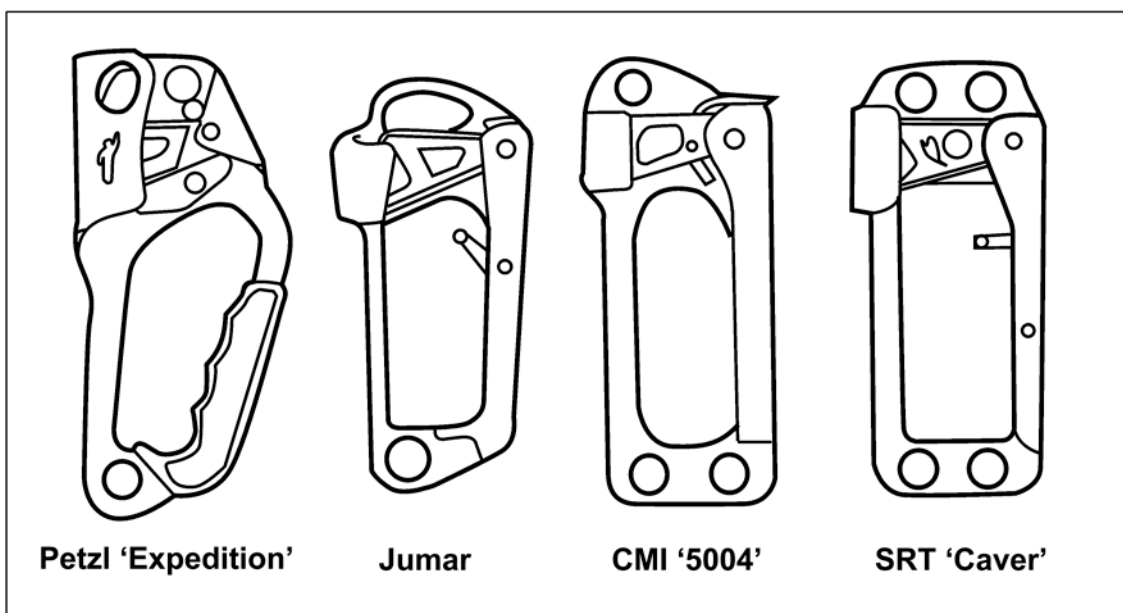

Figure 5–18: Some Common Handled Ascenders

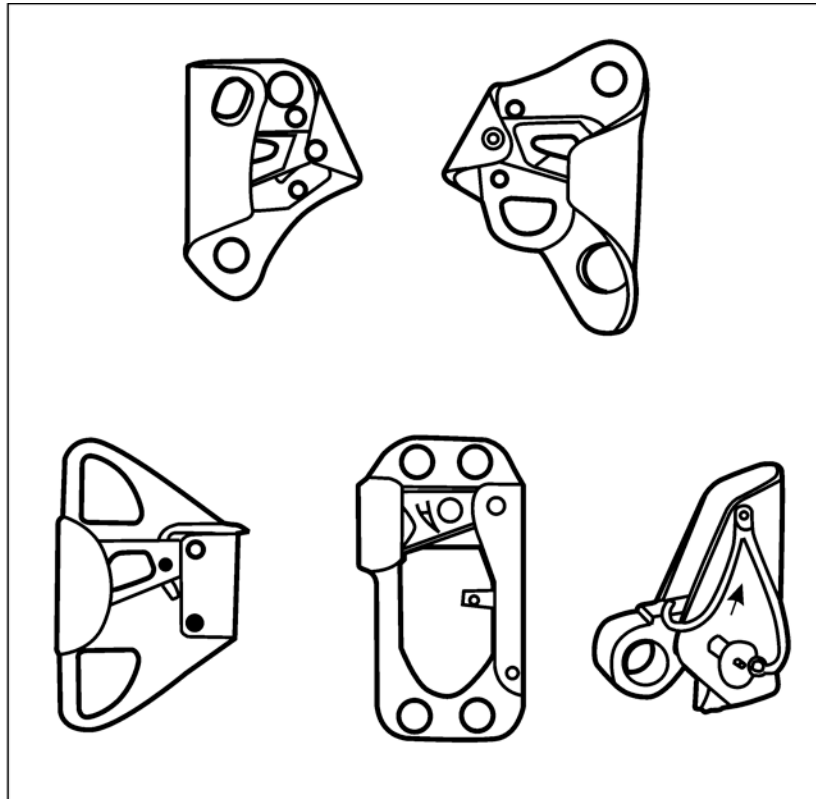

Figure 5–19: Some Common Non-Handled Ascenders

**WARNING NOTE**

**ASCENDERS MUST NEVER BE SUBJECTED TO ANY FORM OF SHOCK LOADING.**

**5.39 WEAR AND WEAKENING**

Spring ascenders begin to slip when their teeth become excessively worn or their springs weaken. This usually becomes apparent when ascending iced or muddy ropes, where the already blunt teeth become clogged.

**5.40 CARE AND MAINTENANCE**

It is possible to purchase replacement cams and springs for most ascenders. The frame of less durable ascenders may also be sufficiently worn that it is better to withdraw the ascender from service. When the frame wears out first, the leading or trailing edge may become razor sharp as the rope wears it away. Ascenders require very little maintenance apart from the obvious need to clean them occasionally.

## 5.41 STRENGTH

The connecting point between the ascender and the rope is the weakest point of the system. Under static loads, most ascenders will cut into the rope sheath and slide before they will fail structurally. The sliding motion normally tends to be arrested by the bunching of the rope and sheath below the cut.

### WARNING NOTE

**MOST ASCENDERS WILL START TO DAMAGE THE ROPE AT BETWEEN 450 AND 600 Kg, AND THE SPEED OF ONSET OF DAMAGE AND THE FINAL EFFECT WILL TEND TO DEPEND ON THE DESIGN OF THE ASCENDER CAM.**

## PULLEYS

**5.42** Pulleys are designed primarily to reduce rope friction. They can be used in mechanical advantage systems, for changing directions on a working rope, or for horizontal/diagonal travel on a rope.

### 5.43 CHARACTERISTICS OF A VERTICAL RESCUE PULLEY

Rescue pulleys should have the following characteristics:

- The **sheave** should have a diameter at least four times the diameter of the rope.
- The **cheek plates** should be moveable so that the pulley can be placed on the rope at any point without having to feed the rope through. They should also extend beyond the edge of the sheave to protect the rope from abrasion.
- The **axle** should have rounded ends which will not snag rope, other gear, or rock.
- The **bearings** should be of such construction as to allow the sheave to turn freely when loaded.
- A **rated strength** in excess of 1500 kg.

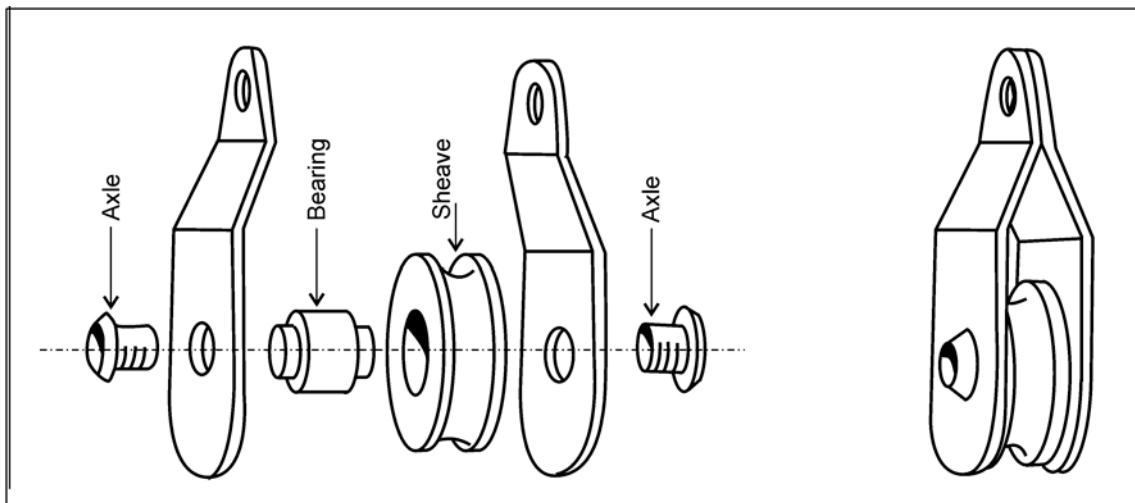

Figure 5–20: Parts of a Rescue Pulley

#### 5.44 SPECIALISED PULLEYS

There are a number of pulleys specially designed for vertical tasks. Among these is the knot passing pulley shown in Figure 5–21. The wide sheaves on these pulleys are designed so that knots such as the Double Fishermans, used to bend rope lengths together, will easily pass over them.

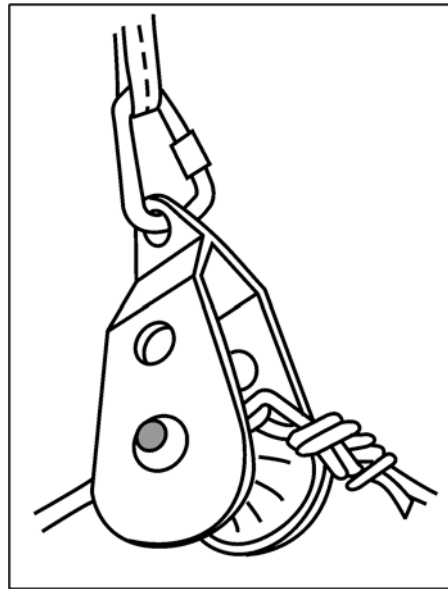

Figure 5–21: Knot Passing Pulley

#### 5.45 KARABINER BACK-UP

Where the strength and integrity of a pulley can not be guaranteed, it can be rigged with a karabiner back-up as shown in Figure 5–22, with the karabiner clipped around the rope on the 'exit' side of the pulley.

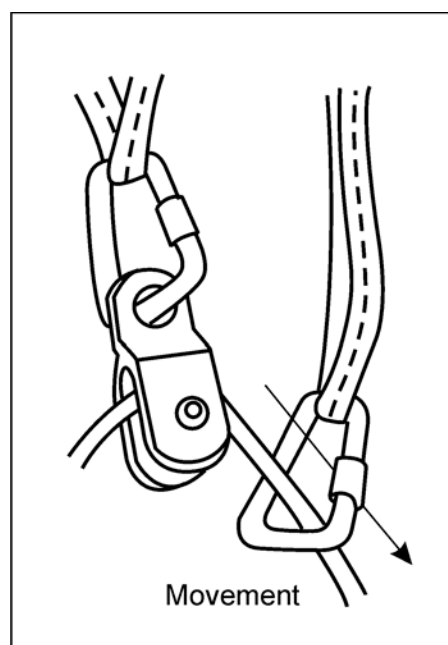

Figure 5–22: Karabiner Back-Up

## 5.46 CARE AND MAINTENANCE

Pulleys must be carefully inspected prior to use to ensure that they are in good condition and will not damage the rope.

## EDGE ROLLERS

5.47 In a vertical operation, the contact which the rope makes with the cliff or building edge will be a critical factor. Whilst edge rollers are quite expensive, they are far more efficient than an edge mat or rope protector, and are a worthwhile investment. They will act to protect the rope passing over an edge, and will greatly reduce friction during a hauling operation. Refer to Chapter 7—Edge Management.

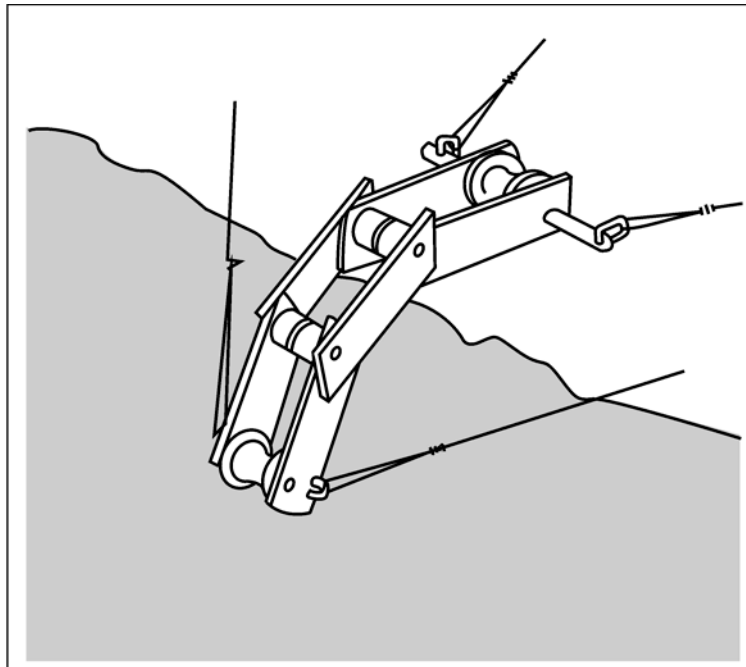

Figure 5–23: Edge Roller

## STRETCHERS

5.48 A seriously injured victim in the vertical environment requires the comfort, protection and security of a rescue stretcher. Improvised stretchers or stretchers designed for 'ground level' operations simply have no place in vertical rescue.

## 5.49 COMMON TYPES

The patients injuries and the environment will dictate the type of stretcher to be used. Some examples of common stretcher types are shown in Figure 5–24.



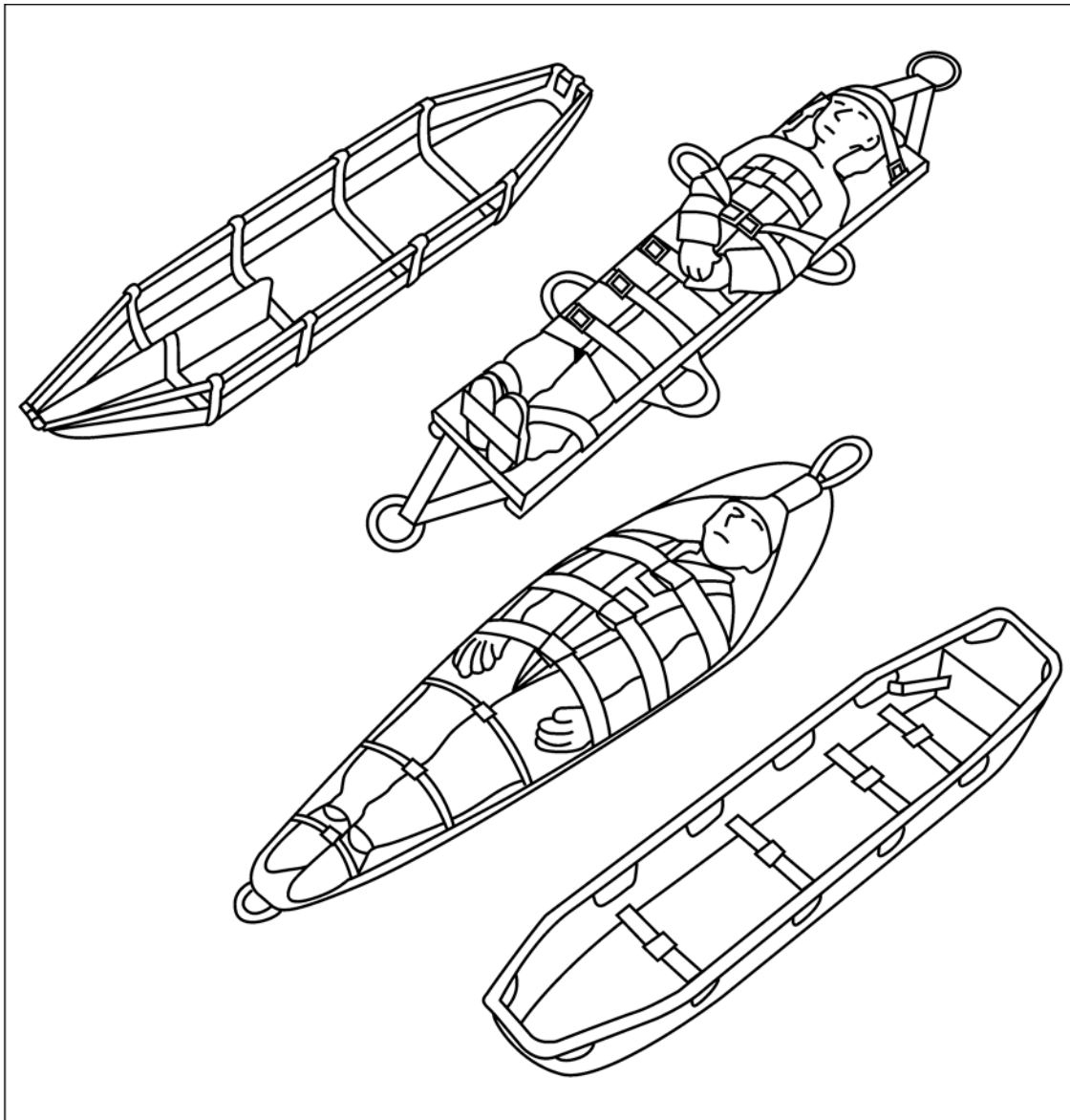

Figure 5–24: Some Typical Rescue Stretchers

## LIGHTING

### 5.50 PORTABLE LIGHTS

One of the most commonly used sources of lighting for rescue is the headlamp. These can range in design and cost from the relatively cheap and reliable climbing headlamps to the very expensive miners headlamps. Units are available with zoom controls for adjusting light intensity, and with dual globes for battery economy.

In addition to the rescuers helmet light, a range of portable lighting units can be used for night operations.

### 5.51 FLOODLIGHTS AND SPOTLIGHTS

Where floodlights and spotlights are used, care must be taken to avoid blinding personnel, and lights should be so set up as to avoid forming areas of deep shadow.

## **5.52 STROBE AND CHEMICAL LIGHTS**

Personal waterproof strobe lights and cold chemical light tubes are available. These can be used to show the location of personnel and equipment. The use of strobe lights must be carefully monitored however, as they can cause temporary blindness to personnel.

- 5.53** Each form of operational lighting has a number of disadvantages. It is recommended that a range of options be tried, and that all rescuers should be trained to operate in night exercises.

## **EQUIPMENT RECORDS**

- 5.54** It is highly recommended that some form of equipment register be maintained for all vertical rescue equipment. In much the same manner as the rope history card system recommended in Chapter 3, such a system should record the acquisition, storage, usage and disposal of the equipment as a strict control measure.



# CHAPTER 6

## ANCHORS

### INTRODUCTION

**6.1** Any ascent, descent or rescue system is reliant upon its anchors. A common cause of accidents in the vertical environment is anchor failure, with most failures as a direct result of human error.

### 6.2 GENERAL PRINCIPLES

The following anchorage principles apply to vertical rescue operations:

- a. When establishing anchor systems, points capable of sustaining multi-directional loads should be selected, and the risk of a severe shock loading must always be considered.
- b. Rescue systems should have a minimum of two independent attachment points, although these can be made to a single strong anchor. Therefore, wherever possible, a belay rope should be anchored independently to a rescue rope.
- c. Anchor systems should be kept as simple as possible, with a minimum number of 'links' in the chain.
- d. Software must be protected against sharp edges and wear points.
- e. Anchor points, slings and attachments must be checked regularly throughout the operation.
- f. Anchors systems should be set up so that the rescue rope crosses the cliff or structure edge as close as possible to a 90 degree angle.
- g. Where multiple anchor points are used, the angle at which the anchor slings meet **must never be more than 120 degrees and should preferably be less than 90 degrees.**

### TYPES OF ANCHORS

**6.3** In vertical rescue there are two classes of anchors. They are described in paragraphs 6.4 and 6.5 below:

### 6.4 NATURAL OR EXISTING

These anchors are those found on the rescue site. They include:

- a. trees and large rocks;
- b. building structures; and
- c. girders, columns, poles etc.

**6.5** The best available point should be selected with due regard to strength, stability and direction of load. Natural anchor points should be used in preference to assembled or improvised points.

## 6.6 ASSEMBLED OR IMPROVISED ANCHORS

A variety of these are detailed below:

- a. **Picket Anchors and Buried Holdfasts**—These are described in the *Australian Emergency Manual—General Rescue*. The use of these types of anchor should never be overlooked in vertical operations, as it may well be that they are the simplest solution to an anchorage problem.
- b. **Vehicles**—In many situations, the simplest and quickest anchor system will involve the placement of a vehicle in the most advantageous position. When vehicles are used, the following points should be considered:
  - (1) The vehicle should be placed at right angles to the direction of load wherever possible.
  - (2) The vehicle must not be required to be moved until the rescue is completed.
  - (3) The vehicle must be immovable. The parking brake should be set, and the vehicle should be in a low gear. Preferably, the wheels should be chocked and the keys removed and handed to the team leader.
  - (4) The attachment should be made to the strongest part of the vehicle that is accessible.
  - (5) Software must be kept clear of areas of contamination, abrasion and heat.
- c. **Pitons, Bolts, Hexcentrics, Friends** and other personal climbing protection may be used in the absence of other anchors. The safe placement of climbing protection requires extensive training and experience which is beyond the scope of this manual. **Appropriate training must be sought from climbing/caving instructors.**

## ATTACHMENT TO ANCHORS

### 6.7 ADVANTAGES OF SLINGS

Slings or independent short ropes should be used for attachment to anchors. This method of attachment provides the advantages of:

- a. maximum use of available rope lengths;
- b. reduction of the risk of damage to the main rope;
- c. speed of attachment; and
- d. ease of replacement.

### 6.8 USE OF TWO SLINGS

Where a single anchor point is used, it is recommended that attachment should be by means of two tape slings connected to the same attachment karabiner. Each point of a multiple anchor system requires only one sling. The use of two slings is recommended to provide additional protection against sling failure due to abrasion/cutting of the tape.

### 6.9 METHODS OF ATTACHMENT

Only **screwgate karabiners** or **maillons** should be used for system attachment to anchor points. Some examples of the use of slings for attachment to anchor points are shown in Figure 6–1.

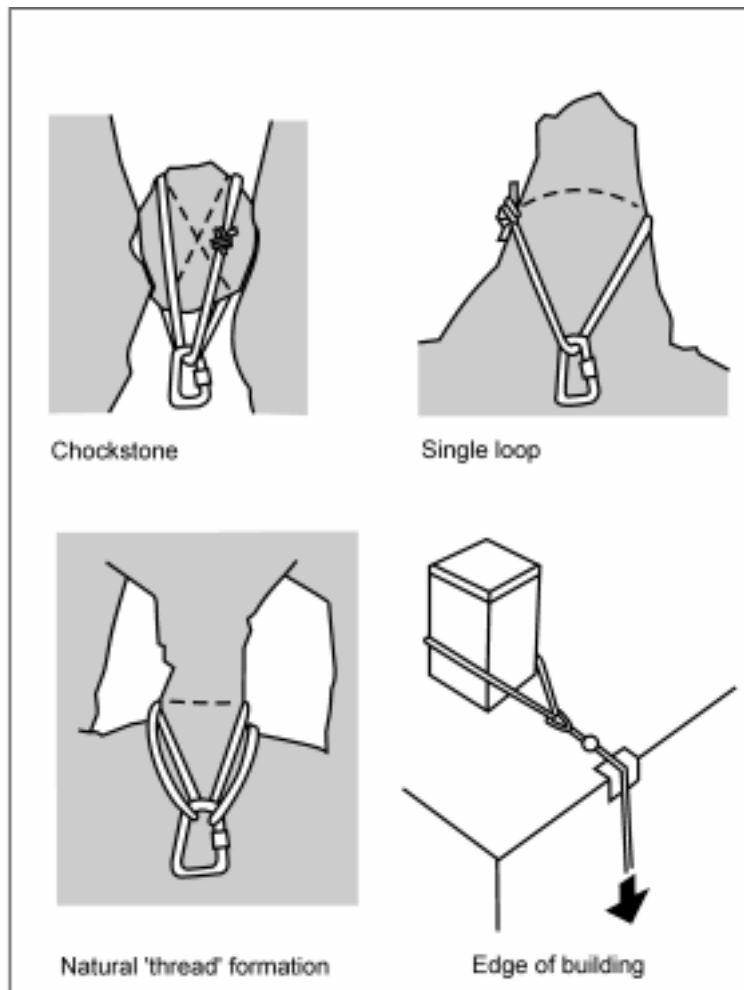

Figure 6–1: Examples—Attachment to Anchor Points

- 6.10** Wherever possible, tape slings should be taken completely around an anchor point, and the karabiner clipped through both sling ends, rather than impose a weakening link by the use of a Larks Head. (Refer Figure 6–1). Slings must be of sufficient length to meet at an angle of 90 degrees or less, so as to allow attachment without overloading the legs of the sling.

**WARNING NOTE**

**ANCHOR KARABINERS SHOULD BE ROTATED OR PLACED SO THAT THEIR GATES ARE FREE OF CONTACT WITH ANY OBJECT.  
(REFER FIGURE 6–2)**

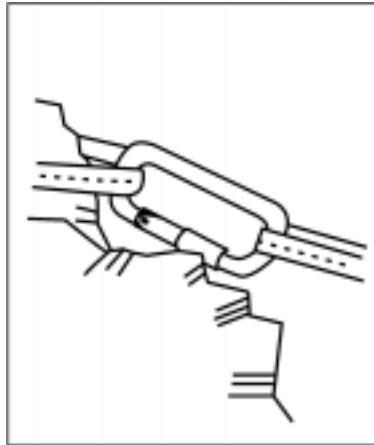

Figure 6–2: Avoid Dangerous Contact

### 6.11 SLING ANGLES AND LOADINGS

When the load must be shared between **two** anchor points, the load is not necessarily shared equally. Too great an angle between the two legs will only achieve an overload of both anchors.

- 6.12 The angle between the two legs should preferably be kept below 90 degrees, and **under no circumstances should it exceed 120 degrees** or excessive loadings will be placed on the two legs of the system (refer Figure 6–3).

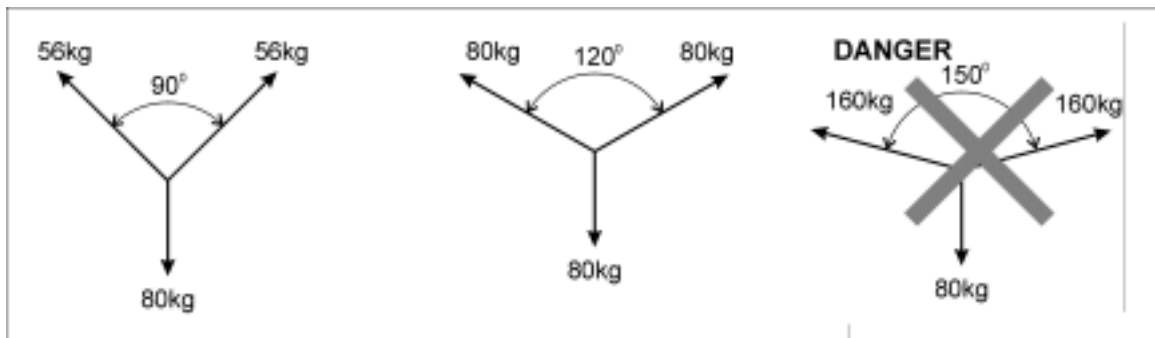

Figure 6–3: Sling Angles and Loadings

- 6.13 The sling leg angles are critical, and the legs must be balanced and adjusted under a test load (where safe and practical) of two rescuers pulling along the operational line from the central attachment point until the load is distributed evenly between the two points. Where one (or both) of the points is remote from the drop, the linking slings must be made long enough to bring the central attachment point close to the work area.

### 6.14 LOAD SHARING SYSTEMS

In some areas, suitable anchors are hard to find, and it may be necessary to use a number of lesser points to construct a system capable of sustaining the load.

**6.15** Special anchorage options such as self-equalising and in-line load sharing systems can be set up to cope with these problems, but it must be understood that their operational requirement tends to be occasional at best. These systems are beyond the scope of this manual, and specialist training should be sought in their establishment, advantages and disadvantages.

## **6.16 CONCLUSION**

The selection of sound and appropriate anchor points is an essential rescue skill. This chapter must be used in conjunction with the relevant sections of the *Australian Emergency Manual—General Rescue* in order to provide the required level of rescuer expertise.





# CHAPTER 7

## EDGE MANAGEMENT

### INTRODUCTION

- 7.1 The safe and effective management of a rescue operation depends to a large extent on the manner in which the rope crosses the cliff or structure edge.
- 7.2 By far the most serious source of abrasion to a working rope is that caused by a sharp or rough edge, regardless of the material the edge is formed from. A severe edge can abrade a loaded rope very rapidly, thus posing a very serious safety risk.
- 7.3 In situations where the edge is causing abrasion, but not to the level of a safety risk, the abrasion is still a problem, as it works against the crew, making hauling systems unnecessarily harder.
- 7.4 Effective edge management should be a standard rescue protocol, and no rigging system should ever be set up without protective measures for all ropes and tapes.

### EDGE MATS

- 7.5 By far the simplest form of edge management is that provided by an edge mat. The mat can be made from heavy-duty canvas or polyethylene sheeting, folded over and stitched around each edge to prevent fraying. A reinforced eye or grommet can be set in each corner for tying the mat down.

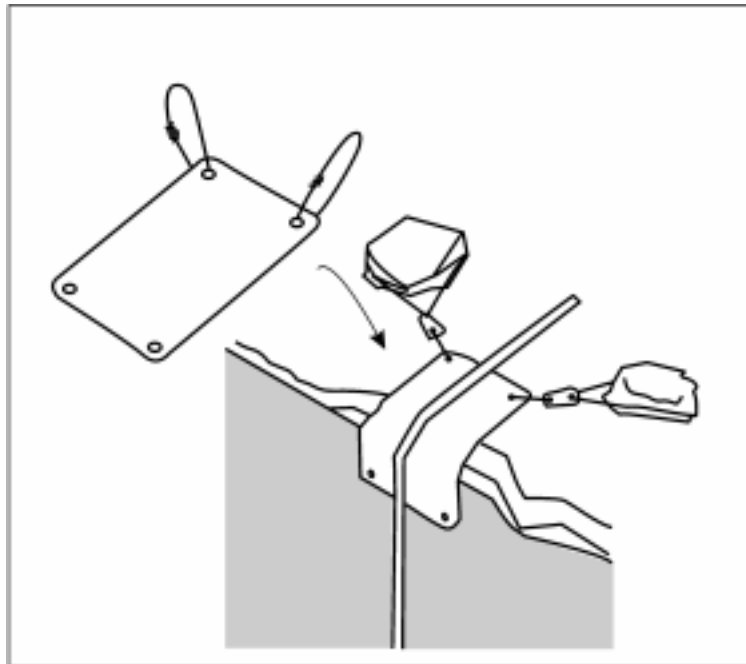

Figure 7–1: Edge Mat

- 7.6 An edge mat can readily be improvised using a sand bag or sacking, full-size tarpaulin, section of rubber conveyor matting, or any similar suitable material.

- 7.7 A range of edge mats in different sizes can be made up to cater for a range of edge situations.

## ROPE PROTECTORS

- 7.8 Unlined canvas fire hose can quickly be converted into rope protectors. In order to avoid having to feed the rope through the hose, it should be modified by slitting it lengthwise and sewing in a Velcro closure as shown in Figure 7–2. A reinforced eye or grommet can be set at each end for securing purposes.
- 7.9 The style of rope protector described above can also be manufactured from sections of any durable and abrasion resistant material, or can be purchased in heavy-duty polyethylene fabric from most vertical equipment suppliers.

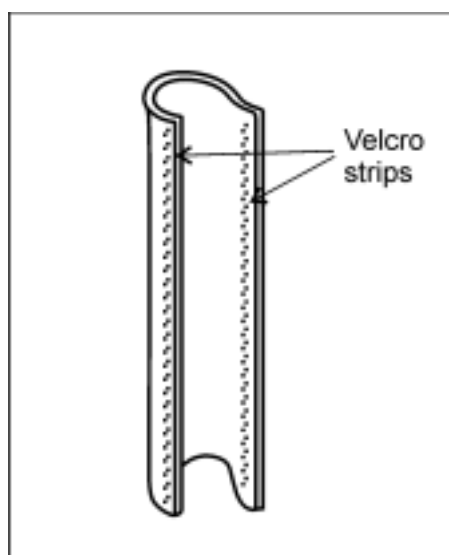

Figure 7–2: Rope Protector

### WARNING NOTE

**WHEN SELECTING MATERIALS FOR EDGE MATS OR ROPE PROTECTORS, BE AWARE OF PRODUCTS SUCH AS RUBBER AND GLUES THAT MAY ADVERSELY AFFECT THE ROPE.**

## EDGE ROLLERS

- 7.10 These are one of the most effective rope protection systems, as they can dramatically reduce the amount of rope and edge contact, thus reducing loads and stresses during a lifting operation.

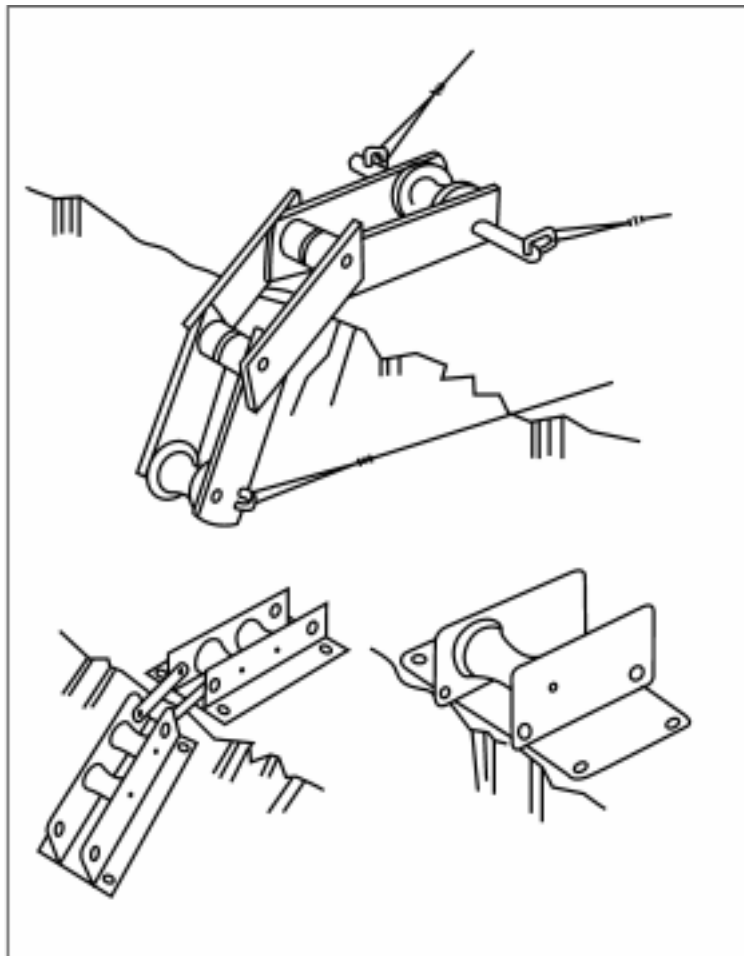

Figure 7–3: Some Typical Edge Rollers

**WARNING NOTE**

**THERE SHOULD BE A MINIMUM TOLERANCE BETWEEN THE EDGE OF THE SHEAVE AND THE SIDE PLATE OF THE EDGE ROLLER TO PREVENT THE ROPE ENTERING THE GAP AND BEING DAMAGED.**

**ROOF ROLLERS**

- 7.11 Some edge rollers are manufactured specifically to manage the 90 degree edge of a roof parapet or similar. Made up either as linked roller units or parapet frames, these rollers are highly effective edge management devices.

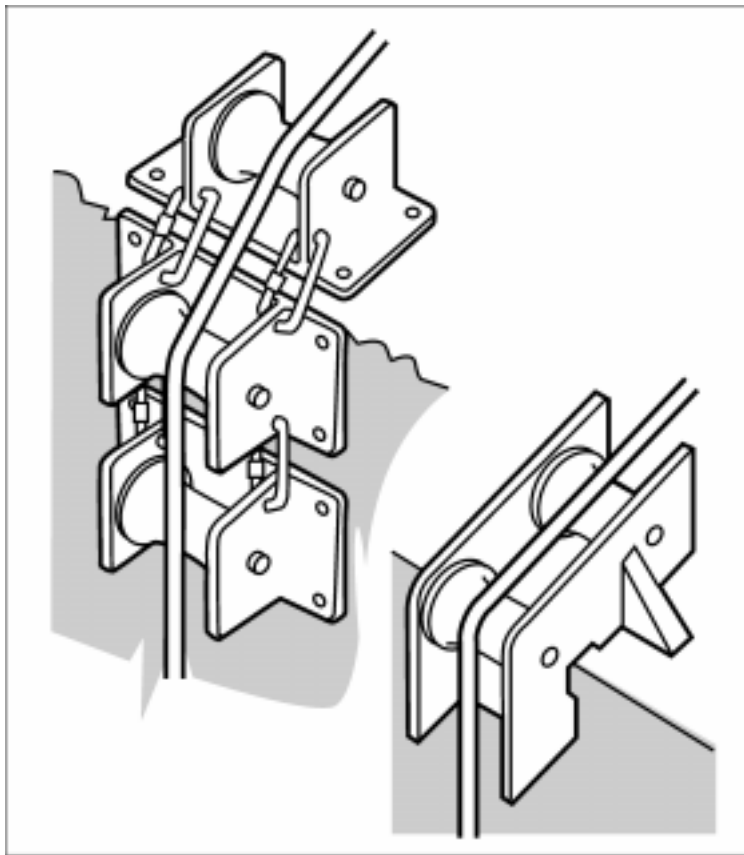

Figure 7-4: Roof Rollers

## RESCUE DERRICKS

- 7.12** The ultimate form of edge management is provided by the use of some form of rescue derrick. Regardless of the design of the derrick, the concept is that of taking the rope up through a pulley on a jib or projection so that the rope runs through the pulley smoothly, and misses the edge completely.
- 7.13** The derricks most commonly used by Australian rescue teams for edge management are the Larkin Rescue Frame (Figure 7-5), the Ozpod (Figure 7-6) and the Crux 2000 (Figure 7-7).
- 7.14** When these or other derricks are selected for use by a rescue team, it is essential that proper training is provided for the team, and that the derrick is integrated into the overall rescue system appropriate to the task and the location.

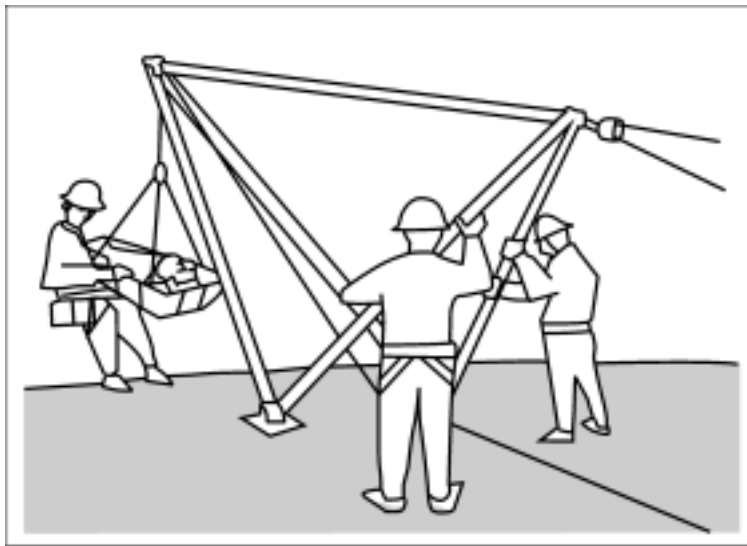

Figure 7-5: Larkin Rescue Frame

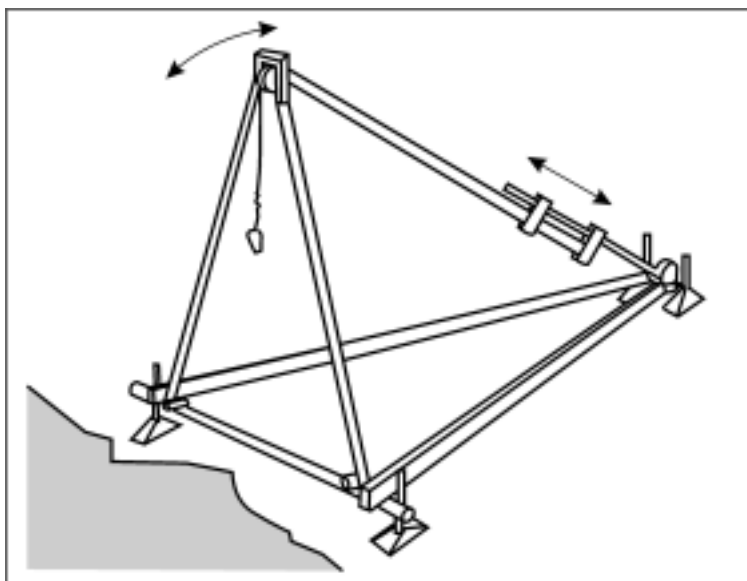

Figure 7-6: Ozpod

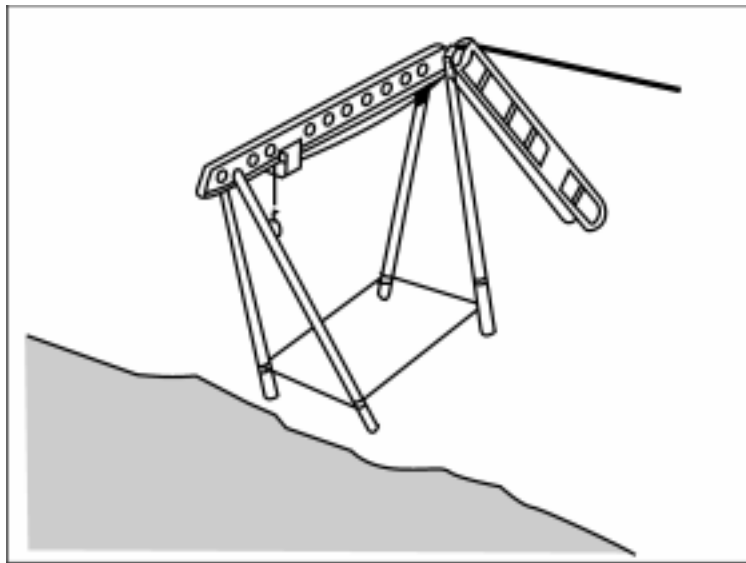

Figure 7-7: Crux 2000

## TRIPODS

- 7.15 Most rescue equipment manufacturers can supply alloy tripods for shaft and pit access. They can be acquired in a range of height extensions, and several have provision for cable winches.
- 7.16 As with rescue derricks, it is important that specialist training in the rigging and use of tripods be obtained from appropriate agencies or instructors.

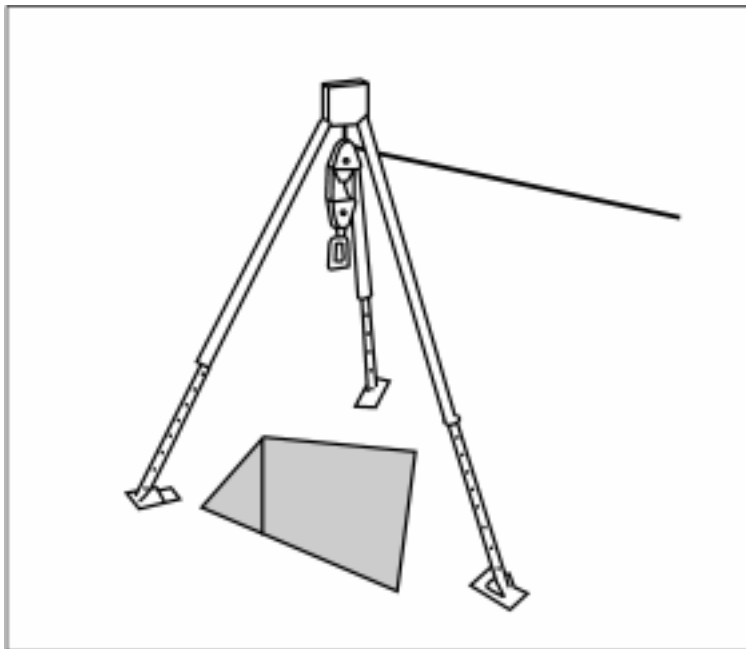

Figure 7-8: Typical Rescue Tripod

## **PIGTAILS**

- 7.17** One form of edge management that should never be overlooked is the rigging of a simple rope 'pigtail' over an edge so that it hangs beside the main rescue rope. The pigtail must be secured to an anchor point separate from the rescue system.
- 7.18** When a stretcher is brought up to a difficult edge, the stretcher escort transfers his/her ascent rig (and weight) from the stretcher tether to the pigtail. From this position on the pigtail, and with the load greatly reduced, the escort can help the belayed communicator to lift the stretcher over the edge while the hauling crew take in the rope.





# CHAPTER 8

## BELAYING

### INTRODUCTION

**8.1** Belaying is the controlling of a safety rope attached to personnel or equipment as a back-up in case of primary system failure.

### **8.2 FRICTION DEVICES**

Whilst most friction devices can be used for belaying, it is recommended that only rated belay devices such as the belay plate or GriGri are used in rescue activities. The Italian Friction Hitch (Munter Hitch) is also acceptable as an improvised belay system.

#### WARNING NOTE

**BELAY SYSTEMS SUCH AS THE BELAY PLATE, GRIGRI AND ITALIAN FRICTION HITCH MUST NOT BE USED TO PROTECT A RESCUE LOAD (CASUALTY AND ESCORT). THEY ARE ONLY RATED TO PROTECT A SINGLE PERSON LOAD.**

### **8.3 USE OF STANDARD CALLS**

The standard calls described in this manual should be used at all times in belaying operations to reduce confusion.

### **8.4 TERMINOLOGY**

Two further terms are used in belaying to refer to the safety rope:

- a. **Active rope** is the run of rope between the working rescuer and the belayer, controlled by the **active hand**.
- b. **Inactive rope** is the spare rope already taken in or ready to pay out, and controlled by the **inactive hand**.

### ESTABLISHING A BELAY

### **8.5 BASIC PRINCIPLES**

A belay should be established according to the following principles:

- a. It must be anchored independently of the primary system.
- b. The belayer must be anchored independently of the belay and not tied into the belay system.
- c. It should be established with the belayer in close proximity to, but clear of, the primary system.

- d. It should be set up close to the operational line of the primary system to avoid rope angle changes.

**WARNING NOTE**

**ALL ROPES USED IN A RESCUE SYSTEM MUST HAVE SIMILAR CHARACTERISTICS TO AVOID UNEQUAL ROPE STRETCH AND LOAD REACTIONS.**

## 8.6 ROPE MANAGEMENT

The belay must be managed so that there is a minimum of slack whilst not actually supporting any part of the load. The belayer must remain alert throughout the operation.

## 8.7 BELAY PLATE

The belay plate is rigged as shown in Figure 8–1, with the rope doubled through the plate slot. Both belay plate and cord tether are then secured to the anchor point by means of a screwgate karabiner. The cord tether is essential to prevent the plate from wandering down the rope in normal use.

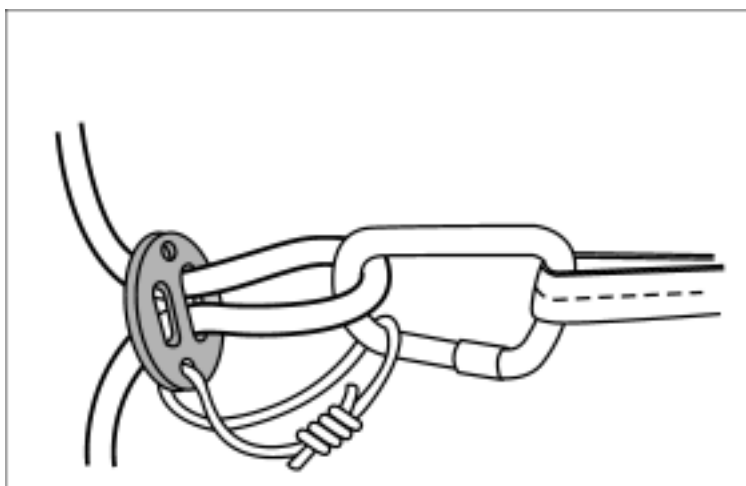

Figure 8–1: The Belay Plate

## 8.8 BELAY PLATE OPERATION

The operating procedure for the belay plate is simple. The belayer holds one run of rope out of the plate in each hand, controlling rope movement by a shuffling action of the hands.

## 8.9 SHOCK LOAD CONTROL

It is vital that the belayer maintains a firm control of the inactive rope **at all times** as this is used to control any shock loading. In the event of a sudden shock load, the belayer holds the inactive rope firmly and pulls this part of rope back towards the anchor point (Figure 8–2).

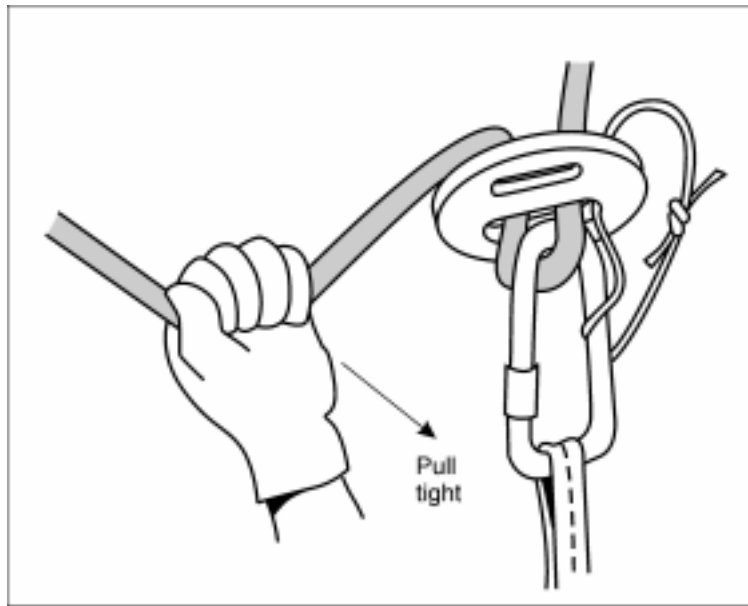

Figure 8–2: Managing the Belay

**8.10 LOCKING THE PLATE**

The belay plate can be locked off securely by threading a bight of the inactive rope through the anchoring karabiner and forming this bight around the active rope with two half hitches.

**8.11 THE GRIGRI BELAY**

The Petzl GriGri is a belaying device designed for 10–11 mm rope, and incorporating a ‘deadman’ system that locks the belay in the event of a sudden shock load catching the belayer unawares.

**8.12** The device is rigged as shown in Figure 8–3. It is critical that the GriGri only be used in accordance with the manufacturers clear directions.

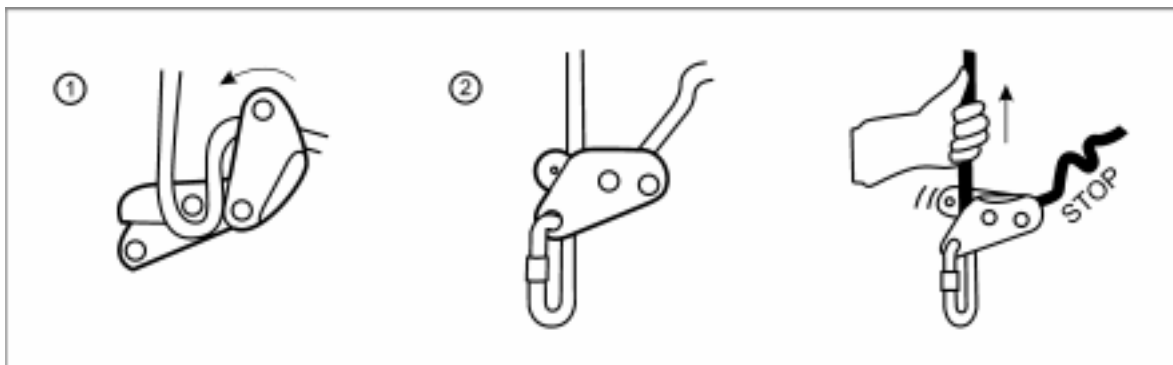

Figure 8–3: Rigging the GriGri

### 8.13 OPERATING THE GRIGRI

The GriGri is operated in much the same manner as a belay plate. As shown in Figure 8–4 the belayer takes a safe stance, in this case for an upward load. The GriGri is secured to an appropriate anchor point, and the belayer controls the movement of the rope through the device by a shuffling hand action.

8.14 In the event that the GriGri sustains a high loading, the handle can be used to lever the cam back from the rope to release it. Control can then be re-assumed with the active hand to lower the rescuer to safety.

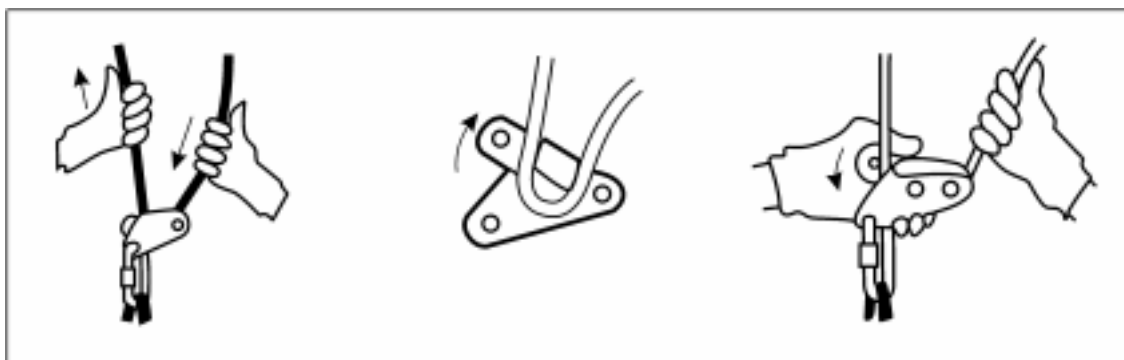

Figure 8–4: Operating the GriGri

### 8.15 THE ITALIAN FRICTION HITCH

The Italian Friction Hitch or Munter Hitch is formed with the belay rope on an anchored karabiner as shown in Figure 8–5. The hitch is controlled in much the same manner as a belay plate, with the shuffling action of the active and inactive hands around the hitch, and with a firm control of the inactive run of rope maintained at all times.

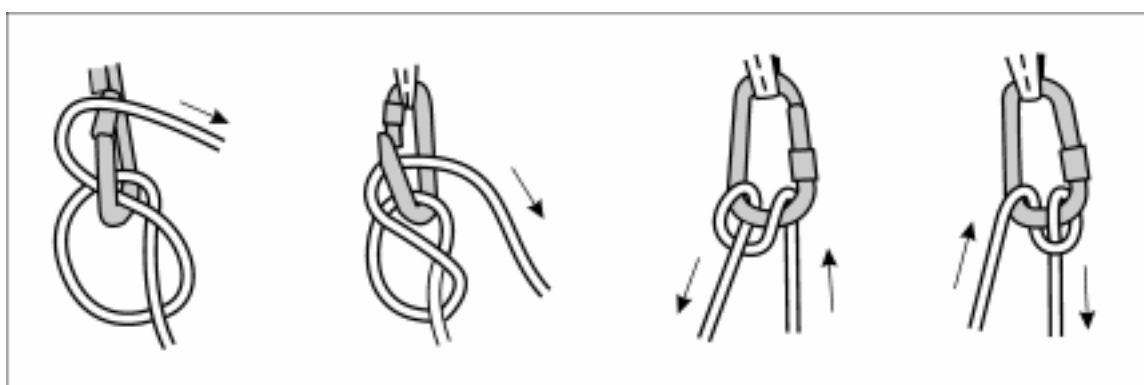

Figure 8–5: The Italian Friction Hitch (Munter Hitch)

### 8.16 LOCKING THE HITCH

The hitch can be tied off as shown in Figure 8–6, by the forming of two half hitches around the active rope with a bight of inactive rope.

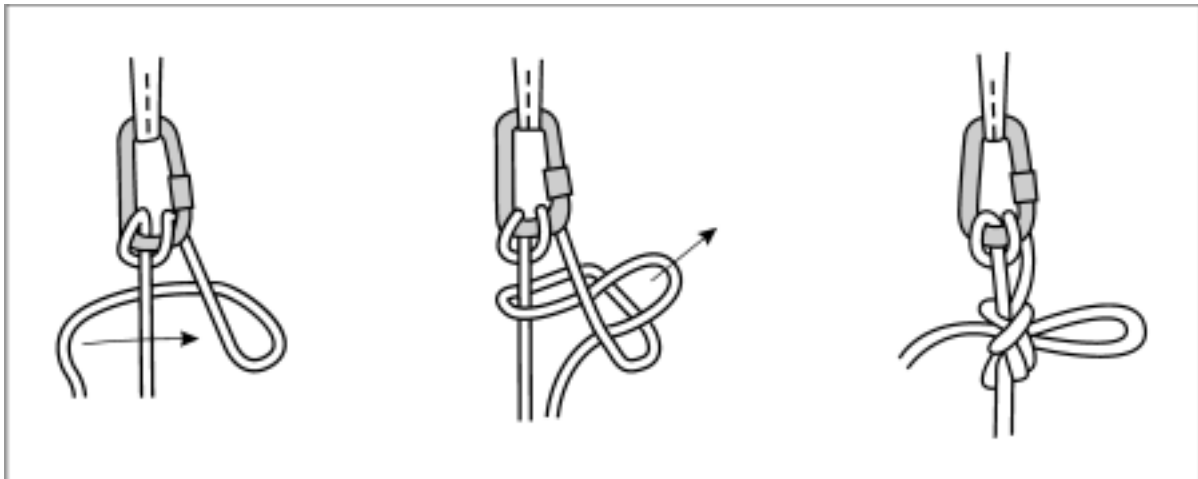

Figure 8–6: Locking the Italian Friction Hitch

## BELAY CALLS

**8.17** The calls used for belaying may vary between organisations however, the following calls are recommended for vertical operations.

CALL	CALLED BY	MEANING
ON ROPE	On rope person	Ready to move
READY	Belayer	Acknowledged
TAKE IN	On rope person	Recover slack rope from the system
THATS ME	On rope person	All slack rope is taken in
SLACK	On rope person	Provide some slack rope
MOVE WHEN READY	Belayer	Belay operational, move when ready
MOVING	On rope person	Starting to move now
HOLD	On rope person	Lock belay and support my weight
CLEAR	On rope person	Belay no longer required
OFF BELAY	Belayer	Belay no longer operational

## 8.18 PROCEDURE

The above calls must be given clearly and concisely and must not be run together as this may cause confusion. **Each call should be responded to.** The response 'OK' is recommended for simplicity.

### WARNING NOTE

**DUE TO THE FORCES IMPOSED UPON THE BELAYER AS THE RESULT OF A SHOCK LOAD, BODY BELAYS ARE NOT RECOMMENDED FOR VERTICAL RESCUE ACTIVITIES.**

## SAFETY

8.19 The following points should be observed at all times:

- a. Belay anchors must be carefully selected and the belay set up clear of any danger zones.
- b. The belayer must wear gloves.
- c. Standard calls must be used.
- d. With any belay, it can be anticipated that some rope will run out of the system under a high load. This provides even greater safety as the belay becomes dynamic. This rope must never be permitted to run out over attachment or other ropes or slings, or friction melting will occur.
- e. The belayer must pay total attention to the task, maintaining 'hands-on' control of the rope at all times.
- f. The belayer must be able to 'lock-off' a belay in an emergency.
- g. As a belay may involve a moving rope on a rock face, the face person must be prepared for loose stones and other material being dislodged by the rope.
- h. All belay attachments must be made with screwgate karabiners.
- i. The belay must be checked by the Safety Officer prior to use.

## CONCLUSION

8.20 Belaying is an essential vertical skill, and while this chapter has described the principles and procedures, there can be no substitute for careful and regular practice.

8.21 It is most strongly recommended that rescuers practice these skills under very close supervision before being responsible for a belay.

# CHAPTER 9

## DESCENT

### INTRODUCTION

#### 9.1 ABSEILING

Abseiling is the method of descending a fixed rope in a **safe and controlled** manner using a friction device.

9.2 Abseiling is only a means to an end, a special technique to be used in specific circumstances. Rapid descents and sport abseiling techniques have no place in vertical rescue.

#### WARNING NOTE

**ABSEILING IN A RESCUE ENVIRONMENT MUST ALWAYS BE CARRIED OUT USING AN ABSEIL FRICTION DEVICE.**

### SAFETY NOTES

9.3 Personnel must be safety checked prior to any descent.

#### 9.4 LOWERING

For safety reasons it is desirable that the first person is lowered down a face. This ensures that the rope reaches its destination without obstructions or knots, and enables a safety person to be available to operate a bottom brake for any further descents.

#### 9.5 REVERSING PROCEDURE

With any descent system, rescuers must practise reversing the procedure so as to be able to ascend a rope. This is a simple action, but it must be practised for safety as there may be situations where it will be required.

#### 9.6 ROPE PROTECTION

Descent ropes running over sharp edges must be protected from damage by the use of edge protection.

#### WARNING NOTE

**ABSEIL FRICTION DEVICES GENERATE A CONSIDERABLE AMOUNT OF HEAT IN USE. THIS IS DETRIMENTAL TO SYNTHETIC FIBRE ROPE, AND DESCENTS MUST BE MADE IN A SLOW AND SAFE MANNER.**



## DESCENT OPERATIONS

### 9.7 PROCEDURE

The following procedure should be adopted before descending:

- a. Check anchor system and rope deployment.
- b. Rig friction device correctly and attach to the harness.
- c. Ensure that the rope passes on the side of the body with the brake hand.
- d. Check braking procedure.
- e. Safety Officer or dispatcher to conduct safety check.

### 9.8 CONTROL AND BALANCE

Downward movement must be in a controlled and balanced manner with the optimum support of the harness. Absorb shocks by bending the knees. It must be possible to stop the descent **easily** at any time and to lock-off quickly and efficiently. **Do not descend at speed and avoid excessive shock loading by bouncing.**

### 9.9 COMPLETION

On completion of the descent, communicate your arrival and safe status. Where appropriate, disconnect from the rope and move to a safe position.

### 9.10 BOTTOM BRAKE OPERATOR

During training and operations a person should be positioned at the bottom of the descent to arrest the fall of an abseiler by applying tension to the rope. If required, this person may lower the abseiler in a controlled manner by reducing the tension on the rope.

## DESCENT DEVICES

- 9.11 Figures 9–1 to 9–8 show the descent devices in most common rescue usage, along with their applications.

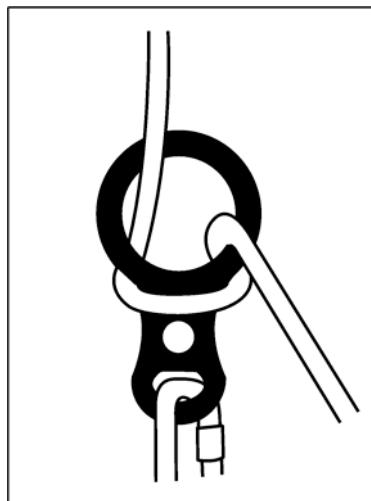

Figure 9–1: Figure 8 Descender

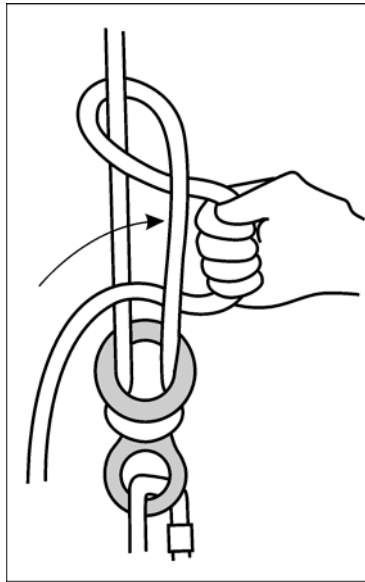

Figure 9–2: Figure 8 Lock-off

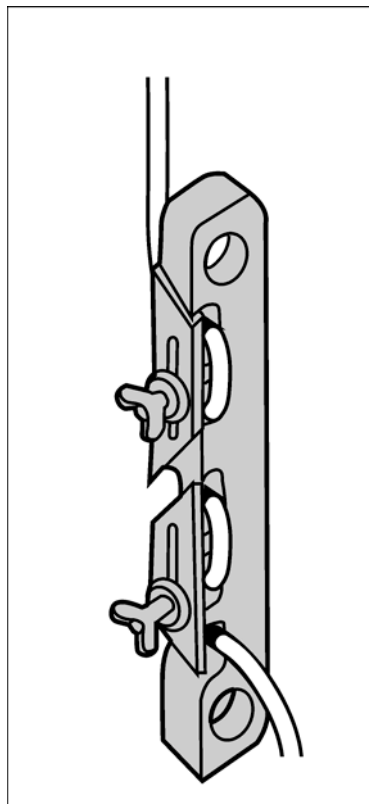

Figure 9–3: Rescue Whaletail

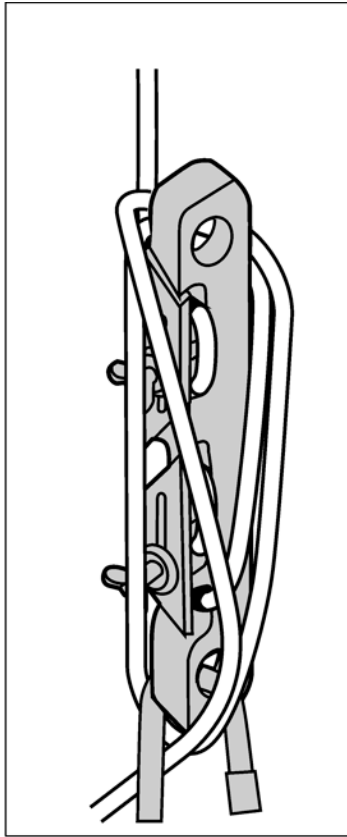

Figure 9-4: Whaletail Locked Off

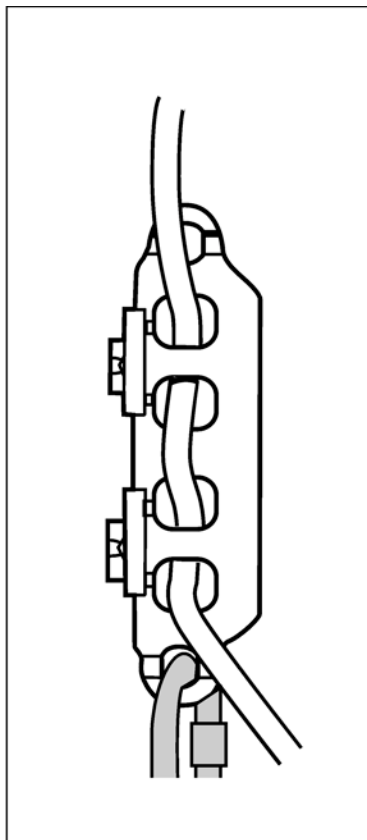

Figure 9-5: Goldtail 200

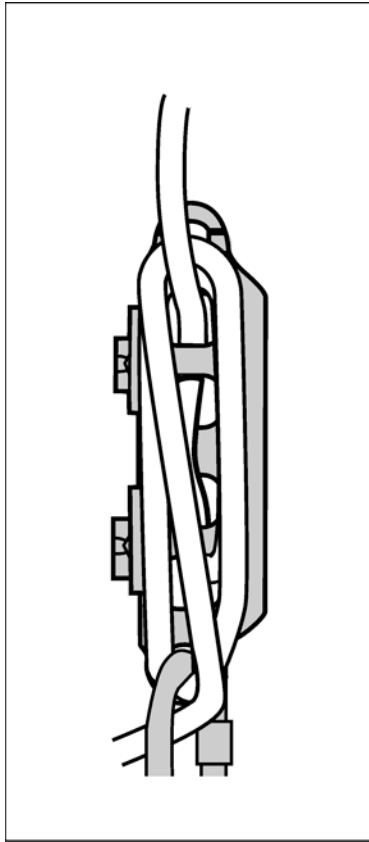

Figure 9-6: Goldtail Locked Off

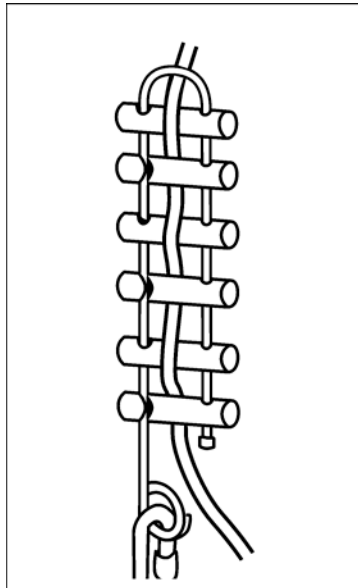

Figure 9-7: Rappel Rack

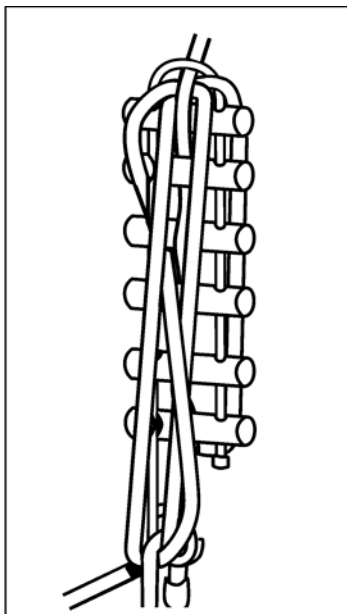

Figure 9–8: Rappel Rack Locked Off

## EMERGENCY DESCENT METHOD

- 9.12** When no friction device is available for whatever reason, the Italian Friction Hitch (Munter Hitch) can be used, formed around the harness attachment karabiner.

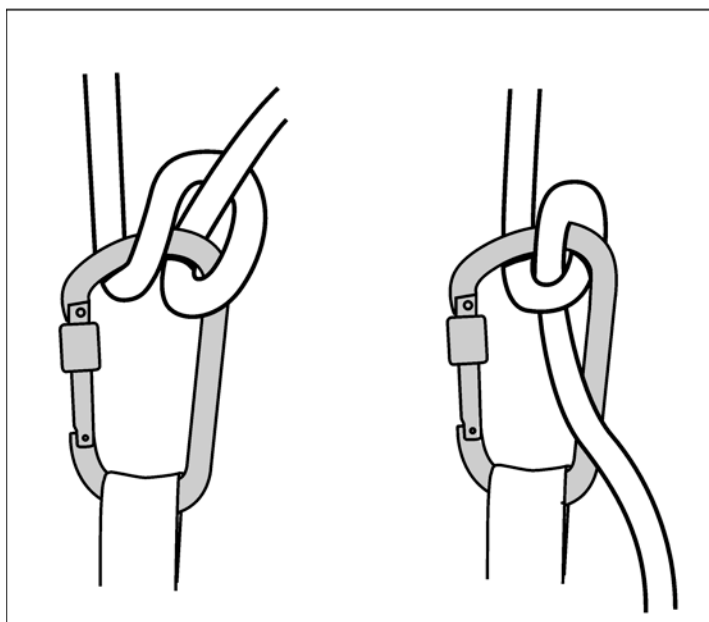

Figure 9–9: Italian Friction Hitch for Abseiling

### WARNING NOTE

**THIS METHOD DOES STRESS KERNMANTEL ROPE TO A CERTAIN DEGREE AND CAUSES EXAGGERATED KINKING OF THE RUNNING END.**

## CHANGING FROM DESCENT TO ASCENT

### 9.13 PROCEDURE

The procedure for changing from descent to ascent is as follows:

- a. Stop the descent and securely lock-off the descender.
- b. Connect an ascender or Prusik loop from the harness to the rope above the descender.
- c. Check that the ascender is secure, then remove the lock from the descender and let out rope until full body weight is supported by the ascender.
- d. Remove the descender from the rope and secure it to the harness gear loops.
- e. Rig the second ascender or Prusik loop (the foot rig) to the rope.
- f. Safety check all attachments prior to ascending the rope.

### GENERAL SAFETY

**9.14** All personnel must carry a means of self rescue such as Prusik loops or ascenders for ascent of the abseil rope.

**9.15** Attention must be paid to ensure beginners and trainees keep their full weight on the rope while descending and do not feel their way down by 'toeing' against the structure or cliff face.

**9.16** A descent directly **above** a casualty **must be avoided**.

### 9.17 STANDARD CALLS

The following calls are standard for abseiling:

<b>CALL</b>	<b>CALLED BY</b>	<b>MEANING</b>
ON ROPE	Descender	ready to move
READY	Belayer	acknowledged
ABSEILING	Descender	moving now
STOP	Anyone	a problem arising
BELOW	Anyone	something falling
CLEAR	Descender	disconnected from rope

### 9.18 RESPONSE

Each call should be responded to. The call 'OK' is recommended for simplicity.



# CHAPTER 10

## ASCENT

### INTRODUCTION

- 10.1** It is essential that the vertical rescuer is able to change from descent to ascent or manoeuvre on a rope tether during a stretcher rescue. This requirement calls for familiarity and practice with rope ascent techniques.

### ASCENT EQUIPMENT

- 10.2** There are two basic types of ascender:

- a. **Friction Knots**—There are several different kinds of these, but the most commonly used, and generally the most effective is the **Prusik Knot**.
- b. **Mechanical Ascenders**—Mechanical ascenders will slide easily up a rope when unloaded, and will lock in position when loaded downwards. The devices are designed for this one-way operation, however, the cam can be pivoted away from the rope when unloaded so as to move the descender down the rope or remove it from the rope.

### 10.3 ROPE PROTECTION

Due to the continual movement of the rope during an ascent operation, known as 'cyclic loading' the placement of rope protection at all points of rope contact is desirable.

### 10.4 BELAYS

During training and under certain circumstances it may be desirable to provide a belay for a rescuer ascending a fixed rope.

### ASCENT SYSTEMS

#### 10.5 THE FROG ASCENT RIG

The frog ascent rig is one of the simplest and most commonly used ascent systems.

#### 10.6 THE FROG RIG WITH PRUSIK KNOTS

With the standard Frog rig shown in Figure 10–1, two stirrups are connected to the lower Prusik loop, while the upper Prusik loop is attached to the harness karabiner. The lower (foot stirrup) Prusik is also connected to the harness by a tape sling for full safety, and the rig is complete. The system is used as follows:



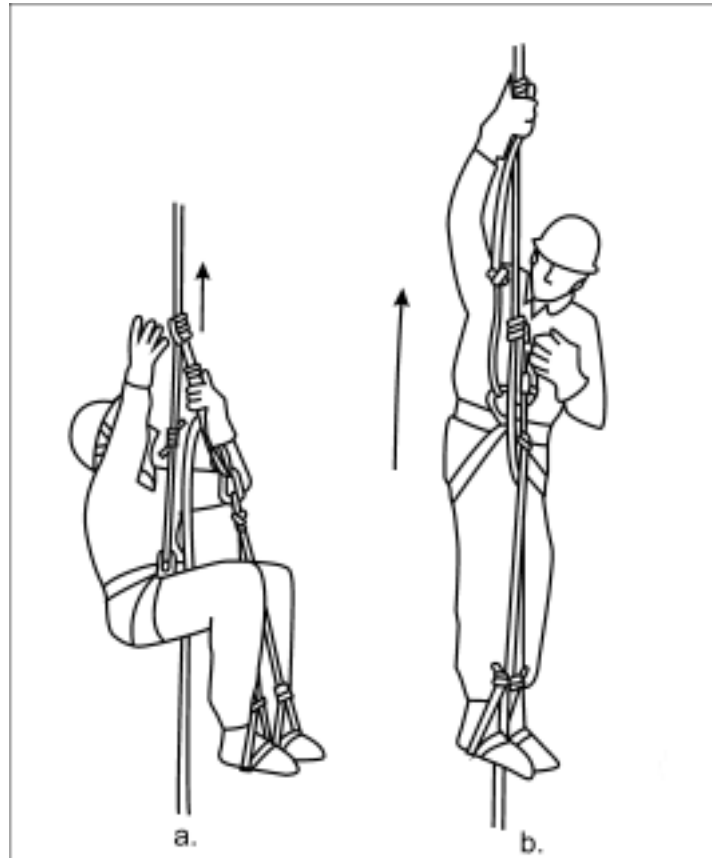

Figure 10-1: Frog Ascent Rig with Prusik Knots

- a. The rescuer sits supported by the harness Prusik while moving the foot rig up the rope (Figure 10-1a). When the foot rig is in position, the rescuer merely stands up in the stirrups (Figure 10-1b) and moves the harness Prusik up the rope to take a higher sitting position.
- b. As additional insurance to the stirrup Prusik moving freely up the rope while in the sitting position, the rescuer can simply grasp the rope below the knot with one hand so as to tension the rope slightly while moving the Prusik knot with the other hand.
- c. The ascent rig must be set up and fine-tuned to suit the individual. The optimum rig is one in which ascent forces are exerted directly down the rope line. Energy expended in any sideways direction is simply wasted.
- d. With the Frog system, the rescuer rests weight on one Prusik while moving the other. Ascent must be made as smoothly and steadily as possible.

## 10.7 THE FROG RIG WITH MECHANICAL ASCENDERS

The system is set up and used as follows:

- a. The standard Frog Rig shown in Figure 10-1 can be set up with mechanical ascenders but the rig **must be modified for safety** and increased efficiency. The foot stirrups must be attached to the higher ascender, and the primary harness attachment to the lower ascender **in a reversal of the Prusik rig** (refer Figure 10-2).
- b. The lower ascender is attached to the harness karabiner by its bottom attachment point, and to a chest harness or loop of **shock cord** around the neck, by the top attachment point.

- c. This double attachment of the chest ascender allows the rescuer to concentrate on moving the foot ascender, while the act of standing up in the stirrups will cause the chest ascender to move up the rope without using the hands.
- d. As additional insurance to the chest ascender harness moving freely up the rope, the rescuer should grip the rope between the feet when executing the standing movement.
- e. Rescuers setting up ascent rigs with mechanical ascenders must practise and fine-tune the rig for personal comfort and efficiency.

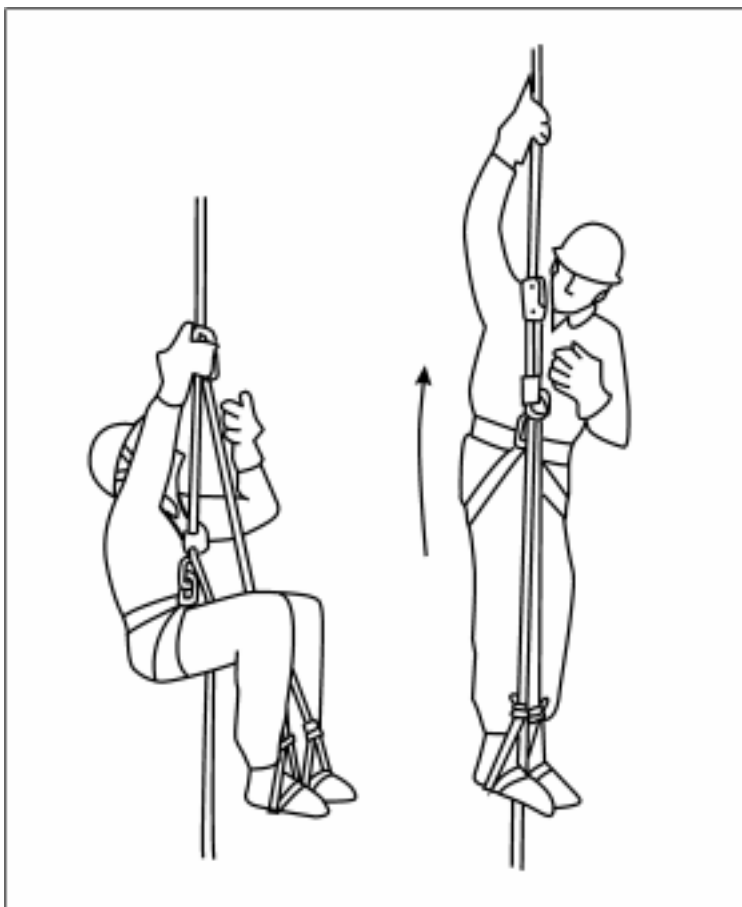

Figure 10–2: Frog Ascent Rig with Mechanical Ascenders

#### **WARNING NOTES**

**NO MECHANICAL ASCENDER IS RATED FOR ANY FORM OF SHOCK LOADING, AND THIS RISK MUST BE CAREFULLY AVOIDED.**

**ASCENDERS MUST ALWAYS BE LOADED IN LINE WITH THE ASCENDER FRAME AND WITH THE ROPE TO PREVENT LOAD DISTORTION AND POSSIBLE FAILURE.**

**WHEN MECHANICAL ASCENDERS ARE USED ON A HORIZONTAL OR DIAGONAL ROPE, A SAFETY KARABINER MUST BE CONNECTED FROM THE ASCENDER TO THE ROPE AS SHOWN IN FIGURE 9–3.**

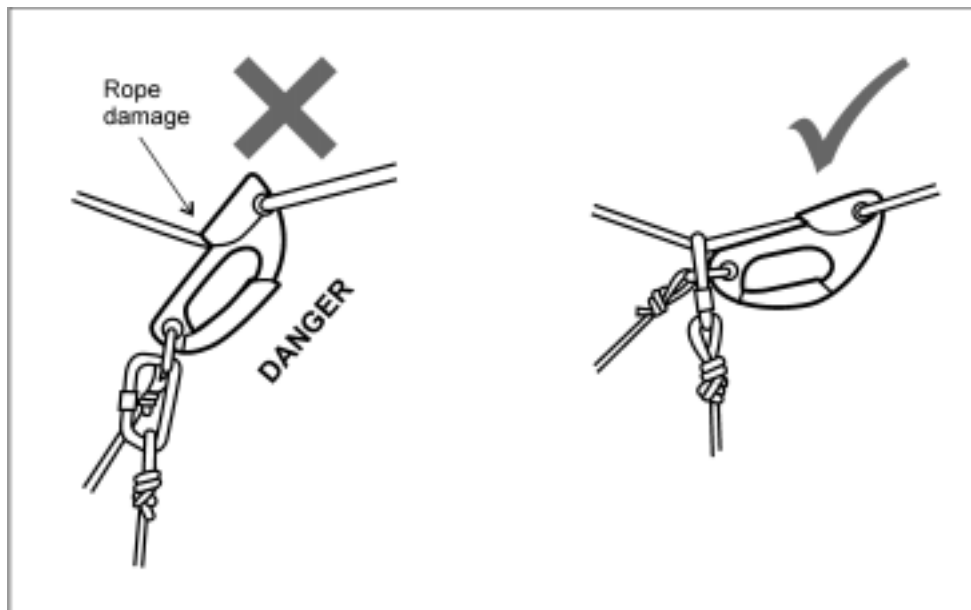

Figure 10–3: Ascender Safety Connection for Horizontal or Diagonal Ropes

## OTHER ASCENT SYSTEMS

**10.8** There are numerous ascent systems that suit different situations and personal preferences. Selection of a technique should be based on ascending efficiency, safety and comfort.

## CHANGEOVER FROM ASCENT TO DESCENT

### 10.9 PROCEDURE

The procedure for changing from an ascent rig to descent is as follows:

- a. Check that the ascent rig from the harness to the rope is set and secure, then remove the foot ascender rig and secure it to the harness gear loops.
- b. Rig the descender to the rope below the harness ascender then connect it to the harness karabiner. With in-line descenders, it is recommended that the descender be connected to the harness before reeving the rope.
- c. Take in all slack through the descender and lock it off securely.
- d. At this stage, the harness ascender must be removed from the rope or tripped so that it will slide down the rope during the abseil. This is best achieved by securing a Prusik cord to the rope below the descender, standing up in this stirrup to unload the ascender and tripping it so that full body weight can come on to the locked-off descender.
- e. Remove the Prusik loop, unlock the descender and abseil to ground level.

## CONCLUSION

### 10.10 GENERAL SUITABILITY

It must be stressed that the techniques and recommendations included in this chapter are those most generally suited to vertical rescue.

### **10.11 PRACTISE**

The standard systems must be practised under controlled and safe conditions until rescuers are proficient in basic techniques. At that time, and not before, each rescuer should then develop and fine-tune his/her own rig.

### **10.12 REVERSE PROCEDURE**

With any ascent system, rescuers must practise reversing the procedure so as to be able to move back down a rope. This is a very simple action, but it must be practised for safety, as there will be situations where it may be required.



# CHAPTER 11

## LIFTING/LOWERING SYSTEMS

### INTRODUCTION

**11.1** The rescue of a trapped or injured person in a vertical environment requires a high degree of skill and experience in ropework, knots, and vertical rescue equipment.

### 11.2 COMMON SCENARIOS

In very general terms, lifting/lowering systems will be required for the recovery of trapped and/or injured persons in the following common situations:

- a. Lower casualty from high point to low level.
- b. Lower rescuer from high point, collect casualty from mid-point and lower to low level.
- c. Lower rescuer from high point, collect casualty at mid-point and recover to high point.
- d. Lower rescuer from high point to low level, collect casualty and recover to high point.

**11.3** The listing of these common scenarios highlights the requirement for an approach in which a lowering system can be rapidly converted for lifting, to reduce delay.

#### WARNING NOTE

**IN ALL CIRCUMSTANCES, RESCUE SYSTEMS MUST BE REVERSIBLE SO THAT THE DIRECTION OF MOVEMENT CAN BE CHANGED AT ANY STAGE OF THE OPERATION.**

### INCORPORATION OF SAFETY BELAYS

#### 11.4 REQUIREMENT

In certain circumstances, dictated either by service operational policy or by on-ground conditions, there will be a requirement to establish a belay or safety rope for the casualty and escort.

#### 11.5 BACK-UP

The belay is for use only as a back up in the event that the main hauling line becomes inoperative, or any element of the rescue system fails.

**11.6** A belay should be anchored independently of the rescue system and controlled at all times so that there is a minimum of slack in the line.

## LOWERING SYSTEMS

**11.7** The rescuer can be lowered to the casualty location either directly by a hauling crew paying out rope (**direct lower**), or with the rope being controlled through an anchored in-line descender (**friction lower**).

### 11.8 DIRECT LOWER

This is a reversal of the basic hauling system shown in Figure 11–1. With this, the hauling system is set up in its entirety, the ascender brake is disarmed, and the crew pays out rope to lower the rescuer. This system allows for a very rapid change of direction by the arming of the ascender brake, and the crew changing to a hauling action.

### 11.9 FRICTION LOWER

With an in-line descender suitably anchored, a single person can control the rope to lower the rescuer to the casualty location. The descender is then locked off, the ascender brake is set up and connected to the rope, and when the hauling system is in place, the in-line descender is removed from the rope but left connected to its anchor for rapid conversion to a lower. A safety belay must then be set up.

## LIFTING SYSTEMS

**11.10** Hauling systems can be set up either with or without some form of mechanical advantage. The decision on the most appropriate method of lifting a casualty and rescuer will primarily depend on the size of the hauling team available.

**11.11** The most commonly used systems are the:

- a. basic hauling system; and
- b. basic mechanical advantage system.

### 11.12 THE BASIC HAULING SYSTEM

This is a very simple direct lifting system. It can be set up as shown in Figure 11–1 with a direction changing pulley where hauling crew work space is limited, or with the hauling crew in a direct line back from the cliff edge. A variable amount of force will be required to overcome the friction created by the edge roller and the pulley.

**11.13** As illustrated in Figure 11–1, an ascender brake or Prusik loop is attached to the rescue line between the edge roller and the redirection pulley. This serves as a safety brake to permit the haul team to rest, and to provide safety in the event of system failure.

**11.14** The ascender is rigged on a short length of rescue rope from an anchored in-line descender so that the brake is reversible for lift to lower transfers, knot passing and so forth. It should be tensioned towards the edge roller with a length of shock cord to maintain clearance with the pulley. Where a Prusik loop is used for this purpose, a rescuer must control it.

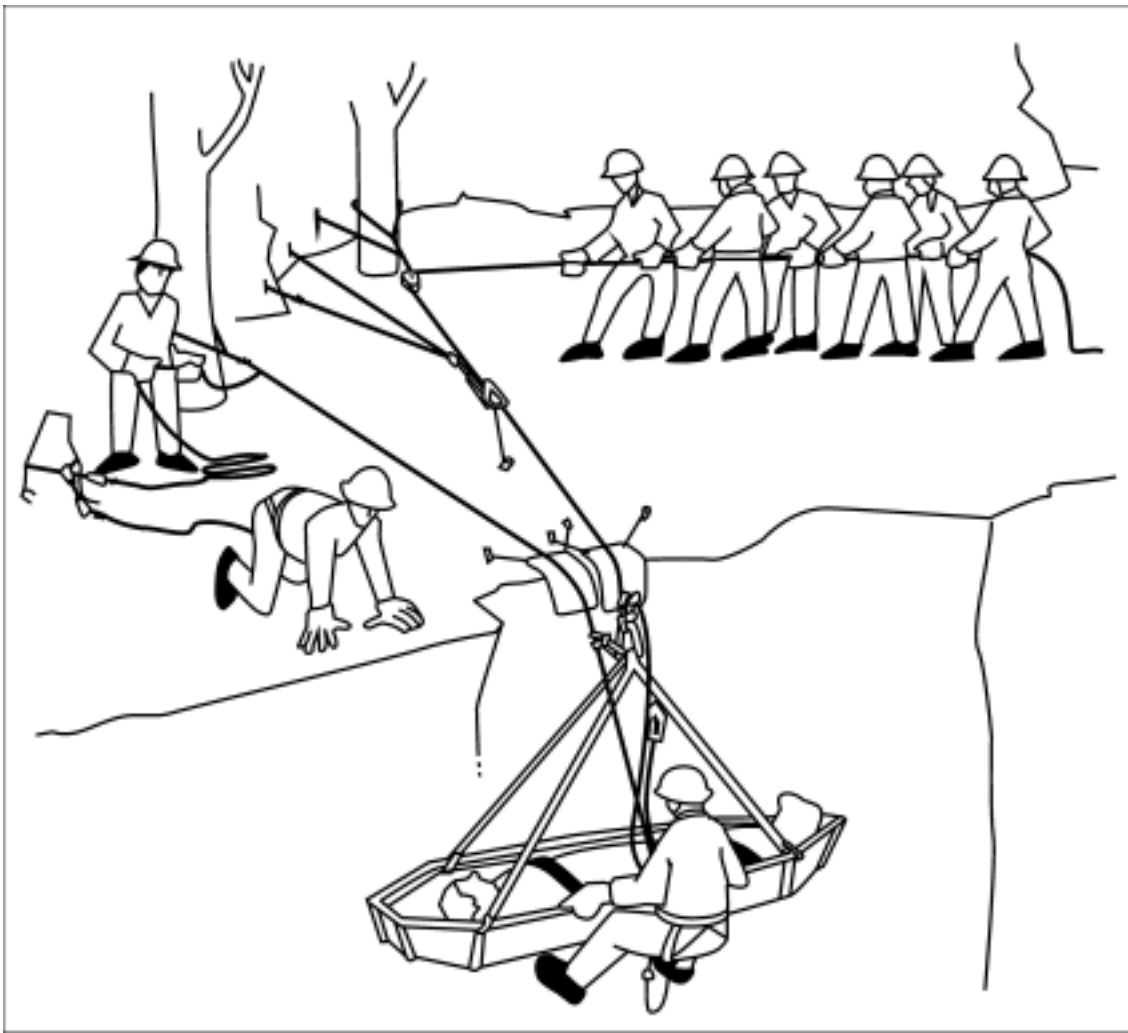

Figure 11–1: Basic Hauling System (shown here with redirection pulley)

**11.15** A communicator and/or team leader should be located as shown in Figure 11–1, on a safety line near the cliff edge but outside any danger zone.

**11.16** The advantages and disadvantages of the basic haulage system are:

a. **Advantages:**

- (1) Simple in operation.
- (2) Minimum equipment.
- (3) Adequate haulage method.

b. **Disadvantages:**

- (1) Limited control.
- (2) 1:1 pull.
- (3) Large safe working area required.
- (4) Large personnel resource required.



## BASIC MECHANICAL ADVANTAGE SYSTEM

**11.17** The 'Z' pulley system shown in Figure 11–2 is the most commonly used and provides a theoretical mechanical advantage of 3:1.

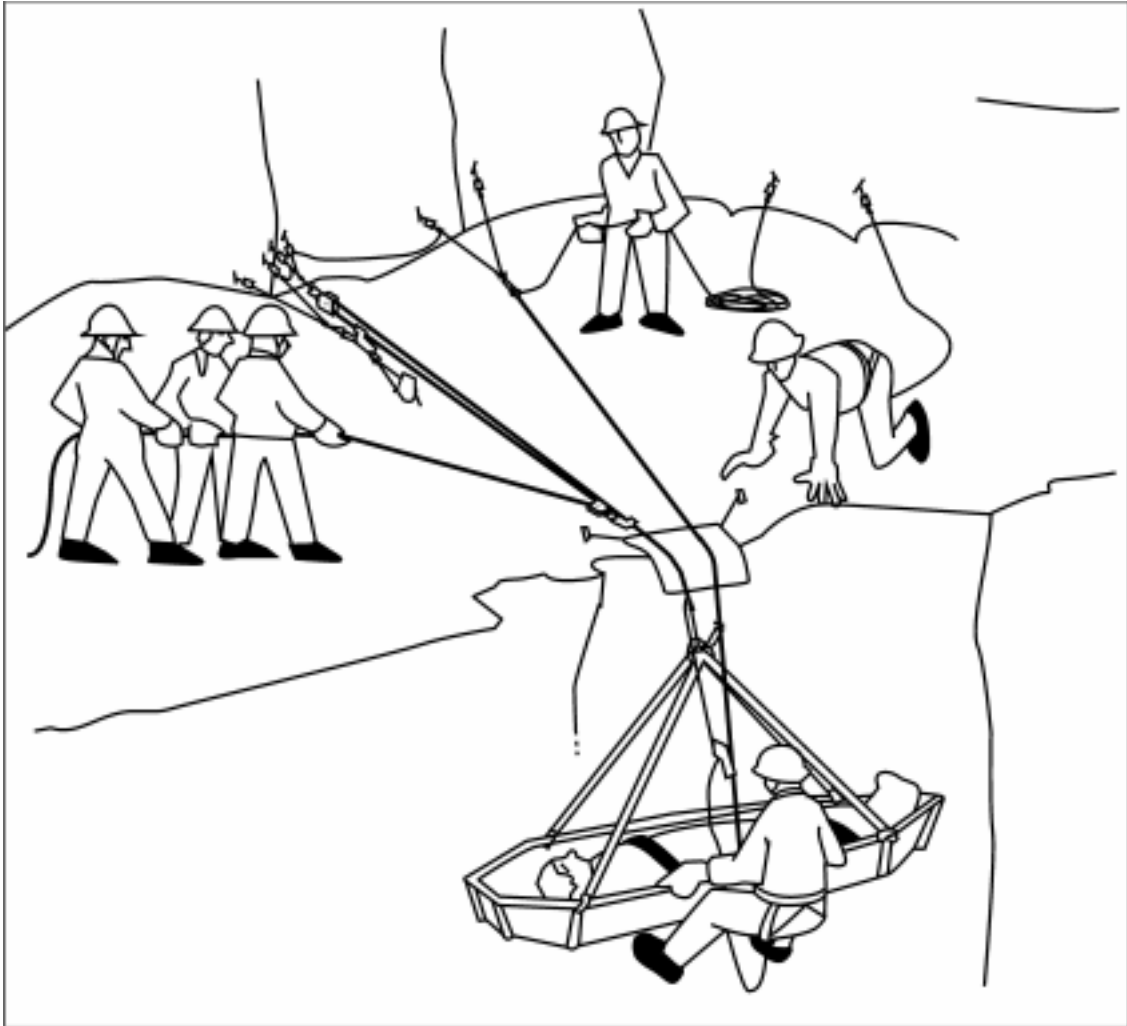

Figure 11–2: Basic Mechanical Advantage System 3:1 Z–Rig

- 11.18** With the use of two pulleys and one ascending device, the system lends good mechanical advantage while keeping hauling components to a minimum. With a reduction of mechanical advantage and efficiency, karabiners can be used in the absence of pulleys.
- 11.19** The 'Z' pulley system shown in Figure 11–2 is a single rope or 'integral Z rig'. An equivalent mechanical advantage can be gained by 'bolting on' the hauling system with an ascender or Prusik loop as shown in Figure 11–3.
- 11.20** This 'bolt-on' approach has the added advantage that the hauling system and the ascender brake can quickly be attached to an existing lowering or abseil rope to permit the recovery of a rescuer with or without a casualty.

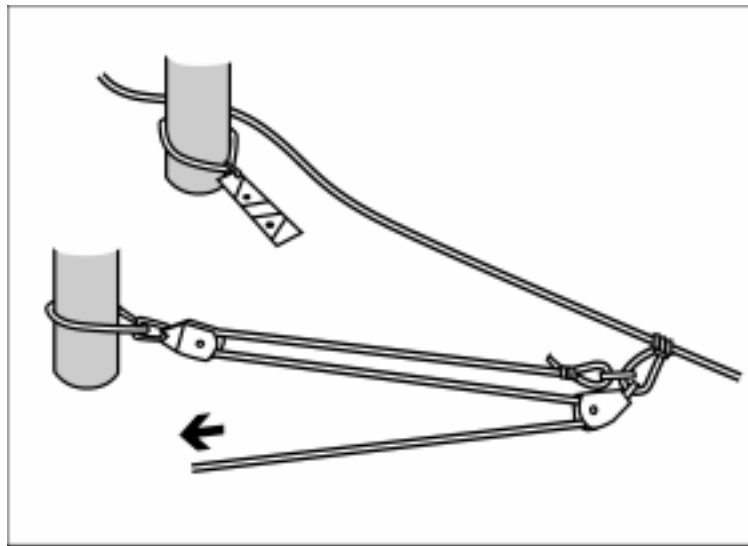

Figure 11–3: 'Bolt-On' Mechanical Advantage System

**11.21** The advantages and disadvantages of the 3:1 'Z' pulley system are as follows:

a. **Advantages:**

- (1) Good control.
- (2) Minimal personnel required.
- (3) System may be set up in confined areas.
- (4) Can be attached to a loaded rope.

b. **Disadvantages:**

- (1) Slow to operate.
- (2) Uses more equipment.
- (3) May require frequent re-setting.

**WARNING NOTE**

**MECHANICAL ADVANTAGES INCREASE THE DANGER OF OVERLOADING THE SYSTEM AND THIS MAY RESULT IN EQUIPMENT FAILURE. THEREFORE THE SYSTEM SHOULD NOT BE SUBJECTED TO A LOAD GREATER THAN THE CAPABILITY OF THE WEAKEST LINK.**

## **DUTIES OF THE HAULING TEAM**

**11.22** Hauling team members must be alert and attentive during the hauling operation. Consideration must be given to the hauling technique, position of the team on the haul line, and the smoothness of the haul. It is recommended that the team take in rope in a 'hand over hand' manner to reduce jerking and uneven movement of the rope.

**11.23** The hauling team must be properly briefed prior to the commencement of the operation, and steps must be taken to ensure that pre-arranged calls are used.

## HAULING OPERATION CALLS

11.24 Suggested calls for hauling operations are:

CALL	CALLED BY
HAULING TEAM READY?	Rescuer
READY	Team leader
UP	Rescuer
DOWN	Rescuer
STOP	Anyone
CLEAR	Rescuer

11.25 The use of hand signals should always be considered as an option for circumstances where voice or whistle calls would not be workable.

## CONCLUSION

11.26 It must be understood that this Chapter deals only with the **basic** lifting/lowering systems in common usage with Australian rescue teams. The application of more advanced systems and problem solving techniques will depend on the individual level of knowledge and experience, developed through practice, producing safe and competent personnel.

# CHAPTER 12

## STRETCHER OPERATIONS

### INTRODUCTION

- 12.1 The recovery of an injured person from a vertical environment requires the bringing together of a wide range of rescue skills with the use of rescue stretchers. **Where any doubt exists as the casualty injuries, a stretcher must be used.**

### CASUALTY PACKAGING

- 12.2 Regardless of the stretcher or recovery system, the casualty must be packaged and secured to the stretcher to prevent further injury.
- 12.3 Chapter 5 of the *Australian Emergency Manual—General Rescue* provides several options for the lashing of casualties to basket stretchers. These techniques are recommended for vertical operations.
- 12.4 Where other styles of rescue stretcher are used, casualties must be secured to the stretcher in the manner recommended by the manufacturer.

### BASIC PRINCIPLES

- 12.5 The following principles should be observed in all vertical rescue stretcher operations:
- The approach to a casualty should always be made carefully and to one side to avoid the risk of causing further injury.
  - Stretcher rescues should be effected using lifting/lowering systems. **Abseil rescues of stretchers are not recommended.**
  - Wherever possible, the casualty should be protected with a helmet and some form of eye protection.
  - A rescuer should escort the stretcher. This person should be rigged on an ascent rig on a rope tether forming part of the stretcher rope system.
  - All components of the rescue system must be rigged with due regard to the loads which must be sustained.

### STRETCHER RIGGING

- 12.6 Depending on the injuries, terrain and conditions, a casualty can be recovered in a horizontal or a vertical attitude (Figures 12–1).
- 12.7 Wherever possible, it is recommended that casualties be recovered in a horizontal attitude, with the stretcher supported by a four point lifting bridle.

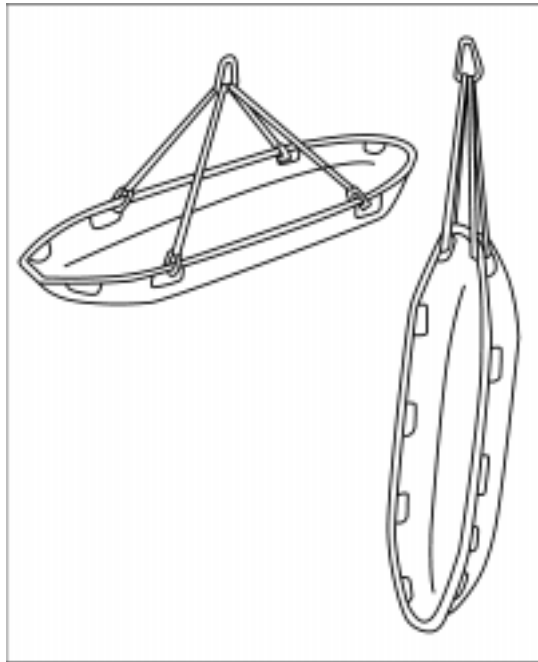

Figure 12-1: Stretcher Attitudes

## HORIZONTAL METHOD

**12.8** When the casualty is secured to the stretcher, the rigging is carried out by:

- a. Attaching a lifting harness or slings to four points of the stretcher so that it will adopt a horizontal position when suspended (Figure 12-2).
- b. Locating the escort centrally beside the stretcher on an adjustable rig that allows movement around the stretcher.
- c. Attaching an independent belay to the stretcher and escort (where required).

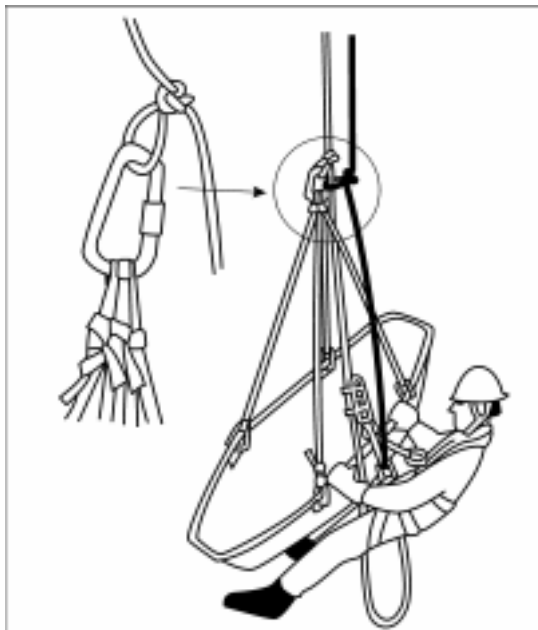

Figure 12-2: Horizontal Stretcher Rig

## VERTICAL METHOD

**12.9** When the casualty is secured in the stretcher, the rescue rope is attached to the head of the stretcher by means of a two-leg lifting sling. Alternatively, for the basket stretcher, two tape slings can be used, or the rope tied directly to the stretcher:

- a. **Two Tape Slings** of about three metres circumference can be used, one for each side of the stretcher as shown in Figure 11:3. Each sling is taken around the frame nearest the stretcher head, then braided around the top rail to distribute the load. The slings are then taken out at the stretcher head so that they meet at an angle of not more than 60 degrees and connected to an attachment karabiner.

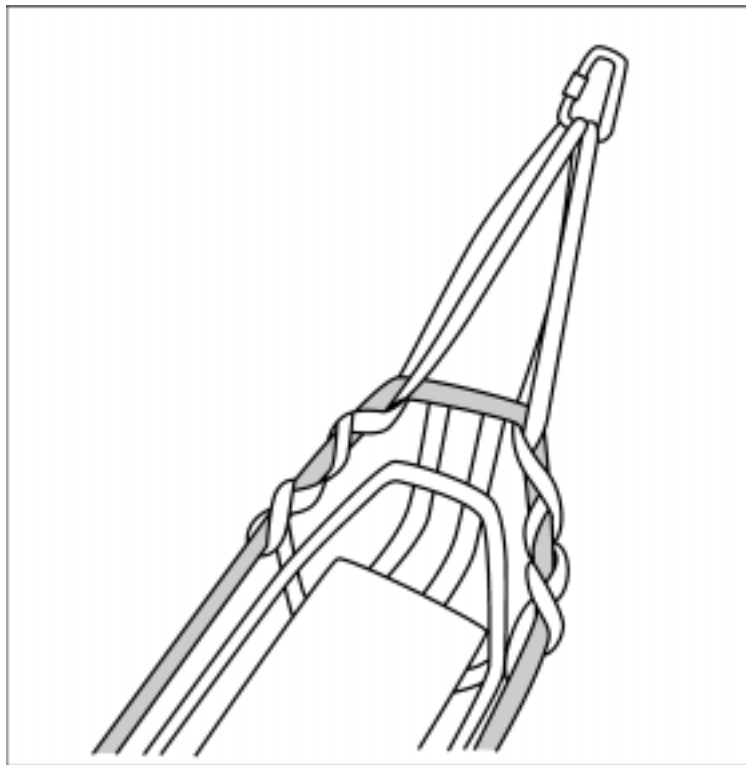

Figure 12–3: Braided Tape Sling Attachment

- b. **Direct Attachment:**
  - (1) The direct rope attachment is rigged by taking the rope in through the head of the stretcher, and around the first frame and the top rail on one side. It is then taken around the top rail and the inward leg of rope to the first frame on the other side, then back out the head of the stretcher, resulting in a braided attachment that distributes the load. Refer to Figure 12–4.
  - (2) The rope is tied off using a pre-rigged Figure of Eight Loop so that the angle formed by the two legs of rope at the knot is not more than 60 degrees.

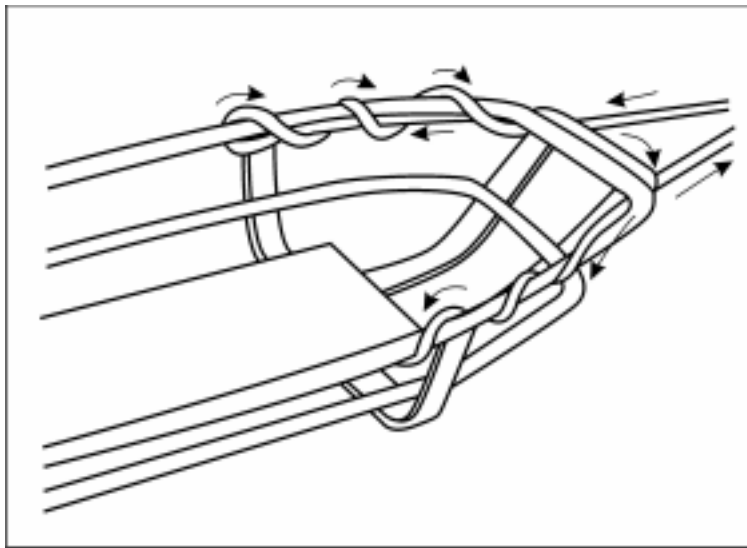

Figure 12–4: Direct Rope Attachment to Stretcher

- (3) The escort is initially located at the foot of the stretcher attached by an ascent rig to a rope tether which allows movement up and down the stretcher as required.
- (4) Where required, an independent belay is then attached to the stretcher and escort.

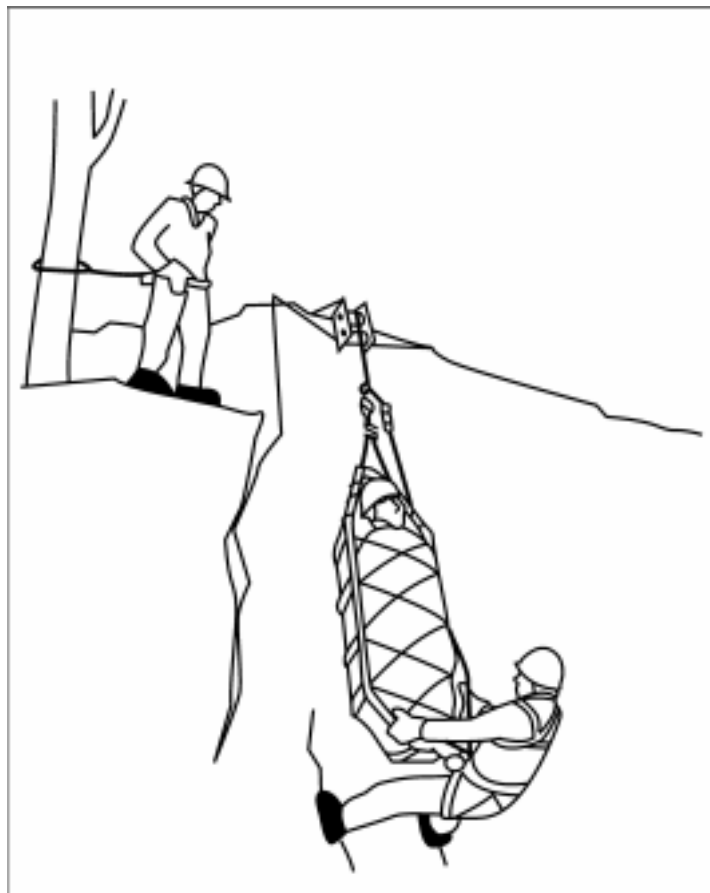

Figure 12–5: Vertical Stretcher Rig

## **TESTING THE RIG**

- 12.10** The rescue system should be tested under load whenever safe and practical to allow for final adjustment.

## **THE ESCORT**

- 12.11** The role of the escort is to monitor and reassure the casualty and to manoeuvre the stretcher over difficult ground.
- 12.12** This role requires skill, strength and regular practice, and requires that the escort be fully rigged with an ascent system on a rope tether attached to the rescue rope. The ascent system provides the degree of mobility that the escort requires to properly assist and support the casualty at all times.

## **TWO ESCORTS**

- 12.13** To meet the needs of the casualty or terrain, two escorts can be rigged, each on a rope tether from the stretcher attachment point to accompany the stretcher. They should position themselves one at each end of the stretcher.
- 12.14** The decision to rig for two stretcher escorts must be made, weighing the advantages of additional casualty support and stretcher mobility against the increased load to be moved by the hauling crew.

## **UNESCORTED STRETCHERS**

- 12.15** The rescue situation may be such that an escort cannot accompany the stretcher. Wherever possible it is recommended that a stretcher guide rope be rigged and controlled from below.
- 12.16** The decision to recover a stretcher casualty without an escort must be made with a careful assessment of the condition and needs of the casualty, and should be considered as the least preferred option.

## **CROSSING EDGES**

- 12.17** The use of cliff machines or rescue derricks is detailed in Chapter 7—Edge Management.
- 12.18** Where a cliff machine or derrick is not available, it is recommended that an additional rope (a 'pigtail') be set up over the edge from a secure anchor point so that it hangs beside the main rescue rope.
- 12.19** On reaching the edge with the stretcher, the escort transfers his/her ascent rig (and weight) from the stretcher tether to the pigtail. From this position on the extra rope, and with the hauling load greatly reduced, the escort can help the belayed communicator to lift the stretcher over the edge while the hauling crew take in the rope.

## **CONCLUSION**

- 12.20** Due to the dangerous nature and high degree of skill required for stretcher operations, the need for on-going training and safety management cannot be over-emphasised.





# CHAPTER 13

## OPERATIONAL MANAGEMENT

### INTRODUCTION

**13.1** This chapter is concerned only with the aspects of on-site operational management.

**13.2** In keeping with standard search and rescue procedures described in the *Australian Emergency Manual—Land Search Operations*, a rescue operation should be based on ‘**LAST**’ sequence as follows:

a. **Locate:**

- (1) Pin-point the location of the casualty.
- (2) Make contact with the casualty.
- (3) Conduct the reconnaissance and appreciation processes.
- (4) Develop the rescue plan.
- (5) Brief the team.

b. **Access:**

- (1) Urgent initial access to the casualty.
- (2) Continue reconnaissance and appreciation.
- (3) SITREP to team leader.
- (4) Update rescue plan.
- (5) Maintain contact and reassure casualty.

c. **Stabilise:**

- (1) Secure the casualty to prevent further harm and render life saving first aid.
- (2) Update information to team leader.
- (3) Package casualty for evacuation.
- (4) Prepare for evacuation.
- (5) Final briefing for team.

d. **Transport:**

- (1) Rescue system in place.
- (2) Conduct final safety checks.
- (3) Evacuate casualty to safety.
- (4) Debrief casualty if appropriate.
- (5) Recover and check equipment.
- (6) Debrief rescue team.

## **COMMAND AND CONTROL**

- 13.3** The rescue operation will be carried out under the command of the team leader. The team leader must direct the rescue team to a safe and rapid recovery of the casualty.
- 13.4** During the evacuation stage, the stretcher escort will give movement commands that the team leader will ensure are executed.
- 13.5** The Safety Officer must oversee the operation. He or she is responsible for ensuring that all aspects of the operation are carried out safely.

## **LEGAL ASPECTS**

- 13.6** An operational log must be maintained throughout the rescue activity.
- 13.7** Where there is a possibility that a Coronial investigation or civil action may ensue, accurate and detailed records must be kept. This is the responsibility of the Police, however local arrangements should be made to ensure this takes place.
- 13.8** Wherever possible, and at the discretion of Police in attendance, photographs should be taken to record the situation.