

**AUSTRALIAN EMERGENCY
MANUALS SERIES**

PART IV

Skills for Emergency Services Personnel

Manual 34

ROAD ACCIDENT RESCUE

Second Edition

EMERGENCY MANAGEMENT AUSTRALIA



Australian Government

Attorney-General's Department
Emergency Management Australia

Copyright

Permission to use the document and related graphics is granted provided that (1) the below copyright notice appears in all copies and that both the copyright notice and this permission notice appear, and (2) use of document and related graphics is for educational, informational and non-commercial or personal use only.

In all cases the Commonwealth of Australia must be acknowledged as the source when reproducing or quoting any part of this publication. Examples and quotations from other sources have been attributed to the original publication whenever possible and are believed to fall within fair use provisions, but these portions retain their copyright protection and must not be used without attribution.

Enquiries related to copyright should be addressed to:

The Director General
Emergency Management Australia
P0 BOX 1020
Dickson ACT 2602

Or telephone (02) 6256 4600 or fax (02) 6256 4653 or email ema@ema.gov.au

Any rights not expressly granted herein are reserved.

Disclaimer

This publication is presented by Emergency Management Australia for the purpose of disseminating emergency management information free of charge to individuals who provide professional training and supervision to members of professional organisations in the field of emergency management. Professional organisations include but are not limited to, professional fire fighters, trained emergency services volunteers, and members of State/Territory police and rescue organisations whose members have training and basic competencies in emergency management services.

The information in this publication is not intended to be used by the general public or untrained persons, and is not a substitute for professional advice and /or training. Untrained persons should not use this publication unless a trained and qualified emergency management professional supervises them and/or their training in the subjects listed in the publication.

Emergency Management Australia in consultation with emergency management professionals and subject matter experts exercises care in the compilation and drafting of this publication, however, the document and related graphics could include technical inaccuracies or typographical errors and the information provided may not be appropriate to all situations. In no event shall the Commonwealth of Australia (acting through Emergency Management Australia) be liable for any damages whatsoever, whether in an action of contract, negligence or other tortious action, arising out of or in connection with the sue of or reliance on any of the information presented in this publication.

Emergency Management Australia periodically updates the information in this publication. Before using this publication please check with the Training Officer in the State Emergency Services organisation in your State/Territory to ensure that this edition is the most recent and updated version of the publication."

First published 1992
Second Edition 1997

ISBN 0 642 27135 6

Edited and published by Emergency Management Australia

Typeset by Director Publishing and Visual Communications, Department of Defence

Printed in Australia by Better Printing

NOTE: Expansion of the Australian Emergency Manuals Series

In August 1996 the National Emergency Management Principles and Practice Advisory Group agreed to expand the original AEM Series to cover a comprehensive range of emergency management principles and practice publications. The new Series incorporates the 20 original AEMs mainly as PART IV of a five-part structure as follows:

- PART I — The Fundamentals
- PART II — Approaches to Emergency Management
- PART III — Emergency Management Practice
- PART IV — Skills for Emergency Services Personnel
- PART V — The Management of Training

From November 1996, the title, number and Part-colour of relevant new or revised EMA publications will reflect their place within the structure. Additionally, manuals in Part IV will be individually colour-coded to match the original AEMs. Existing manuals will remain current until their review date when they will be revised and integrated into the new Series. Commencement of this transition is indicated in the lists below.

**Original AUSTRALIAN EMERGENCY MANUALS SERIES
(available until integrated into new series upon review)**

AEM—DISASTER RESCUE (3rd edition)	AEM—INSTRUCTIONAL TECHNIQUES
AEM—FOUR-WHEEL-DRIVE VEHICLE OPERATION	AEM—FLOOD RESCUE BOAT OPERATION
AEM—COMMUNICATIONS	AEM—COMMUNITY EMERGENCY PLANNING GUIDE (2nd edition)
AEM—TRAINING MANAGEMENT	AEM—CHAINSAW OPERATION
AEM—MAP READING AND NAVIGATION	AEM—VERTICAL RESCUE
AEM—DISASTER MEDICINE	AEM—DISASTER RECOVERY

New AUSTRALIAN EMERGENCY MANUALS SERIES

PART III—Emergency Management Practice

Volume 1—Service Provision

Manual 1 EMERGENCY FOOD SERVICES

Volume 2—Specific Issues

Manual 1 EVACUATION PLANNING GUIDELINES
Manual COMMUNITY EMERGENCY PLANNING (3rd edition)

PART IV—Skills for Emergency Services Personnel

(Manuals will be issued subject to guidelines in the Foreword, page v)

Manual 1 STORM DAMAGE OPERATIONS (2nd edition)
Manual 2 OPERATIONS CENTRE MANAGEMENT
Manual 3 LEADERSHIP
Manual 4 LAND SEARCH OPERATIONS (2nd edition)
Manual 5 ROAD ACCIDENT RESCUE (2nd edition)
Manual 6 RESCUE (4th edition) (formerly Disaster Rescue)
Manual COMMUNICATIONS (2nd edition)

PART V—The Management of Training

Manual 1 TRAINING MANAGEMENT (2nd edition)

Publishing status (5/97): A=Available; D=Development; R=Revision; P=Planned

FOREWORD

PURPOSE OF THIS MANUAL IS TO PROVIDE A NATIONAL REFERENCE FOR ROAD ACCIDENT RESCUE OPERATIONS. IT IS INTENDED FOR USE IN PLANNING, TRAINING AND OPERATIONS BY ALL EMERGENCY PERSONNEL AND ORGANISATIONS. IT IS NOT INTENDED TO PROVIDE POLICY TO STATES AND TERRITORIES ON THE RESPONSIBILITIES OF DIFFERENT SERVICES TO RESPOND IN RESCUE SITUATIONS.

ROAD ACCIDENT RESCUE (RAR), BY ITS VERY NATURE, IS A HIGH-RISK ACTIVITY. EMERGENCY MANAGEMENT AUSTRALIA ACCEPTS NO RESPONSIBILITY FOR ANY ACCIDENT OR INJURY CAUSED BY MISUSE OR MISINTERPRETATION OF INFORMATION CONTAINED IN THIS MANUAL. MOREOVER, THE READING OF THIS MANUAL ALONE CANNOT BE CONSIDERED ADEQUATE TRAINING FOR A RESCUER. KNOWLEDGE MUST BE LINKED WITH TRAINING, PRACTICAL EXPERIENCE, AND STRICT ADHERENCE TO SAFETY.

THIS MANUAL HAS BEEN DEVELOPED BY A NATIONAL CONSULTATIVE COMMITTEE REPRESENTING POLICE, FIRE, STATE AND TERRITORY EMERGENCY SERVICES AND AMBULANCE SERVICES. THE MANUAL IS DESIGNED AS A BASIC REFERENCE COMMON TO ALL STATES AND TERRITORIES. IT MUST BE SUPPORTED BY STATE/TERRITORY DEVELOPED SUPPLEMENTS RELATING TO SPECIALISED ASPECTS OF RAR, SUCH AS EQUIPMENT, OPERATIONAL PROCEDURES AND TRAINING REQUIREMENTS. THE WORKING PARTY WAS INITIATED AND SPONSORED BY THE NATURAL DISASTERS ORGANISATION.

THE MANUAL IS ISSUED IN LOOSE-LEAF FORM TO FACILITATE AMENDMENT AND INSERTION OF INDIVIDUAL ORGANISATIONAL SUPPLEMENTS.

AS SITUATIONS CHANGE AND IMPROVED TECHNIQUES ARE DEVELOPED, THE ROAD ACCIDENT RESCUE MANUAL WILL BE AMENDED AND UPDATED BY THE NATIONAL CONSULTATIVE COMMITTEE.

PROPOSED CHANGES SHOULD BE FORWARDED TO THE DIRECTOR GENERAL, EMERGENCY MANAGEMENT AUSTRALIA, AT THE ADDRESS SHOWN BELOW, THROUGH THE RESPECTIVE STATE/TERRITORY EMERGENCY MANAGEMENT ORGANISATION.

THE USE OF TRADE NAMES IN THIS MANUAL IS NOT INTENDED TO BE RESTRICTIVE, PREFERENTIAL OR PROMOTIONAL, RATHER, TRADE NAMES ARE USED WHERE DESCRIPTIVE CLARITY IS REQUIRED.

THIS PUBLICATION IS PROVIDED FREE OF CHARGE TO APPROVED AUSTRALIAN ORGANISATIONS WHO MAY OBTAIN COPIES THROUGH THEIR STATE OR TERRITORY EMERGENCY SERVICE HEADQUARTERS WHICH MAINTAINS A DISTRIBUTION/AMENDMENT REGISTER.

TO SUPPORT THE INTERNATIONAL DECADE FOR NATURAL DISASTER REDUCTION THE AUSTRALIAN GOVERNMENT WILL ALLOW APPROVED OVERSEAS ORGANISATIONS TO REPRODUCE THE PUBLICATION WITH ACKNOWLEDGEMENT BUT WITHOUT PAYMENT OF COPYRIGHT FEES. MANUALS MAY BE SUPPLIED TO OTHER AUSTRALIAN OR OVERSEAS REQUESTERS UPON PAYMENT OF HANDLING/SHIPPING COSTS (COVERING AMENDMENTS). ENQUIRIES AS NOTED BELOW.

CONSIDERATION WILL BE GIVEN TO REQUESTS FROM DEVELOPING COUNTRIES FOR MULTIPLE COPIES WITHOUT CHARGE.

ENQUIRIES SHOULD BE SENT TO THE DIRECTOR GENERAL, EMERGENCY MANAGEMENT AUSTRALIA, PO BOX 1020, DICKSON ACT 2602, AUSTRALIA. (FACSIMILE: 616-2377665, E-MAIL: EMA@EMA.GOV.AU).

CONTENTS

	Page
AMENDMENT LIST	iii
FOREWORD	v
CONTENTS	vii
	Para
CHAPTER ONE	ROAD ACCIDENT RESCUE ORGANISATION
	Aim 1.01
	Functions 1.02
	Systems Approach 1.03
	First Aid 1.04
	Team Composition 1.05
	The Psychology of Rescue 1.06
	Rescue Workers 1.09
	Group 1—Survivors 1.10
	Group 2—Untrained Personnel 1.11
	Group 3—Trained Personnel 1.12
	Personal Traits of the Rescuer 1.13
	Personal Behaviour 1.14
	The Operational Sequence 1.16
	Decision Making 1.17
	Safety in Training and Operations 1.18
CHAPTER TWO	PREPARATION
	Introduction 2.01
	Selection of the Rescue Vehicle 2.03
	Types of Rescue Vehicles 2.04
	Design Considerations 2.04
	Standard Model Vehicles 2.05
	Custom-Built Vehicles and Modules 2.06
	Road Accident Rescue Trailers 2.07
	Selection of Road Accident Rescue Unit Equipment 2.08
	Readiness of the Rescue Vehicle and Equipment 2.09
	RAR Training 2.12
	Rescue Team Composition 2.17
	Leadership 2.18
	Personal Safety 2.19
	Protective Equipment 2.20
	Correct Lifting Techniques 2.21
	Avoiding Injury 2.22
	Annex:
	A. Recommended Equipment

CHAPTER THREE

RESPONSE

Introduction	3.01
Response	3.02
Receipt of the Call	3.03
Initial Advice	3.03
Exact Location	3.04
Number of Persons Trapped/Injured	3.05
Type of Vehicles Involved	3.06
Hazards	3.07
Traffic	3.08
Non-Traffic	3.09
Name of Informant and Contact Arrangements	3.10
Informing Other Services	3.11
Road Accident Rescue Response Information	3.12
Aide-Memoire	3.13
Travelling to the Scene	3.14
The Driver	3.14
Factors Affecting Travel to the Scene	3.15
Traffic Volume	3.16
Weather Conditions	3.17
Detours	3.18
Road Conditions	3.19
Arrival at the Scene	3.20
Access	3.20
Initial Actions	3.21
Preliminary Assessment	3.22
Concealed Casualties	3.23
Arrival	3.24
Positioning Emergency Vehicles	3.25
Situation Report	3.27

Annex:

- A. Aide-Memoire—Response Information

CHAPTER FOUR

INCIDENT MANAGEMENT

Introduction	4.01
Assessment	4.03
Establishing Liaison	4.04
Command Post	4.05
Initial On-Scene Assessment	4.06
Inner Circle Assessment	4.08
Outer Circle Assessment	4.09
Situation Reports	4.10
Hazard Control	4.14
Evaluating and Neutralising Hazards	4.14
Types of Hazards	4.15
Support Functions	4.16
Considerations	4.20
Action Circle	4.21
Equipment Holding Area	4.22
Human Resources Staging Area	4.23

CHAPTER FIVE

GAINING ACCESS

Introduction	5.01
Emotional Support	5.02
Personal Contact	5.03
Voice Contact	5.04
Casualty Confidence	5.06
Casualty Comfort	5.08
Vehicle Construction	5.09
Component Materials	5.10
Passenger Cars	5.13
In-Built Safety Systems	5.16
Passenger Vans	5.17
Utilities	5.18
Four-Wheel-Drive Vehicles	5.19
Gaining Access for First Aid	5.20
Door Entry	5.24
Glass Management	5.28
Laminated Glass	5.29
Roof Entry	5.30
Casualty Protection	5.31
Boot Entry	5.36
Floor Entry	5.38
Buses/Coaches	5.40
Emergency Exits	5.42
Bus/Coach Alternative Access	5.43
Doors	5.43
Door Air Valves	5.44
Rear Window Exits	5.45
Rear Window Variations	5.46
Easy-Release Windows	5.47
Window Handles	5.48
Side Emergency Exits	5.49
Side Window Emergency Exits	5.50
Other Windows	5.51
Through the Body	5.52
Floor Hatches or Through the Floor	5.53
Luggage Bin Locations	5.54
Lounge Hatches	5.55
Common Roof Hatches	5.56
Roof Hatch Variations	5.57
Typical Emergency Access Points	5.58
Bus/Coach Electrical System	5.60
Battery Switch	5.61
High Voltage Wires	5.62
Bus/Coach Fuel	5.63
Bus/Coach Suspension	5.64
Trucks	5.66

Semi-Trailers	5.69
Trailer Brakes	5.70
Refrigerant/Air-Conditioning Gases/Liquids	5.71
Stopping Diesel Engines	5.72
Fibreglass Panels	5.73
Summary	5.74
Operations Sequence	5.75

Annex:

- A. Supplementary Restraints

CHAPTER SIX

EMERGENCY CARE

Introduction	6.01
First Aid	6.02
Priorities	6.02
Breathing	6.04
Heartbeat	6.05
Bleeding	6.06
Compression and Spinal Injury	6.09

Annexes:

- A. First Aid Priorities
 B. Haemorrhage Control
 C. Communicable Disease
 D. Compression (Crush) Injury
 E. Spinal Injury

CHAPTER SEVEN

DISENTANGLEMENT

Introduction	7.01
Disentanglement Activities	7.02
Considerations	7.03
Release	7.04
Use of Hands	7.05
Hidden Protrusions	7.08
Minor Obstructions	7.09
Clearing a Path	7.10
Casualty Protection	7.11
Widening Openings	7.12
Seats	7.14
Steering Wheel/Column	7.16
Steering Wheels	7.17
Steering Columns	7.18
Air Bags and Supplementary Restraints	7.19
Panel Metal Entrapment	7.20

Head Through Windscreen	7.21
Shard Removal	7.22
Collar Fitting	7.23
Alternative Method	7.25
Impalement	7.26
Dash Hinge Technique	7.27

CHAPTER EIGHT

REMOVAL AND TRANSFER

Introduction	8.01
Removal	8.02
Personnel Liaison	8.03
Techniques	8.04
Post-Removal	8.05
Transfer	8.06
Techniques	8.07
Moving the Casualty	8.08
Lifting	8.09
Planning	8.10
Techniques and Improvisation	8.11

CHAPTER NINE

TERMINATION

Introduction	9.01
Final Check	9.02
Vehicle and Surroundings	9.03
Removal of Debris	9.04
Responsibility	9.05
Termination of Operations	9.06
Clean-Up and Equipment Servicing	9.08
Equipment	9.08
Hygiene	9.10
Reports	9.11
Operational Debrief	9.12
Benefits	9.12
Structure	9.13
Critical Incident Stress Debrief (CISD)	9.14
Why do we need CISD?	9.15

Annex:

- A. Debrief Check List

CHAPTER ONE

ROAD ACCIDENT RESCUE ORGANISATION

AIM

1.01 To provide a reference for road accident rescue (RAR) operations in Australian states and territories.

Note: This manual should not be regarded as a self-teaching medium and is provided as a reference only. Any training on, or practical adaptation of the methods or techniques covered in this publication, should be conducted by a qualified instructor.

FUNCTIONS

1.02 To effectively perform the road accident rescue role of providing lifesaving support to trapped and injured persons and subsequently their extrication, personnel should possess a knowledge of:

- a. the systems approach to road accident rescue;
- b. basic first aid;
- c. other agency roles and resources;
- d. the importance of scene integrity;
- e. the basic construction of motor vehicles;
- f. relevant equipment;
- g. the techniques employed to effect extrication; and
- h. critical incident stress and the importance of effective operational and emotional debriefing.

Note: Rescue personnel need to be aware that legislation varies throughout the Commonwealth. They should make themselves aware of the legislative or policy requirements in their state/territory for the provision of RAR activities.

1.03 SYSTEMS APPROACH

A systems approach to road accident rescue can be described as a sequence of inter-related events that will enable achievement of a safe, effective and efficient rescue.

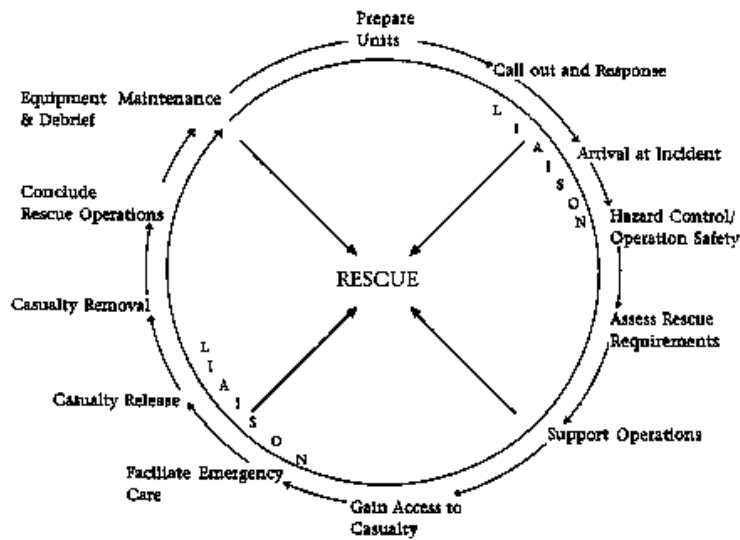

Figure 1:1
Systems Approach Wheel

1.04 FIRST AID

ALL RESCUERS SHOULD BE TRAINED IN BASIC LIFE-SUSTAINING FIRST AID TO RECOGNISED STATE OR TERRITORY STANDARDS (Refer to Chapter 6).

TEAM COMPOSITION

1.05 Team composition must be determined by the various organisations within each state and territory on the basis of SAFE accomplishment of set tasks. Regardless of the team composition, a team leader must be appointed.

THE PSYCHOLOGY OF RESCUE

1.06 People tend to react differently to danger, but the most general responses are anxiety and fear, perhaps the most powerful of all emotions. It must be remembered that it is not just the casualty who faces the danger. Even if the main danger has struck and passed, additional dangers are still often present. The biggest difference between the casualty and the rescuer is that the rescuer is better able to cope with, or handle the situation. This is because the rescuer has the knowledge and the resources to minimise risk and to remedy the situation.

1.07 It is normal to be anxious and feel fear in the face of danger. These are emotional reactions common to both casualty and rescuer. Many other emotional responses may develop during a rescue situation—pity, disgust, contempt, pride, concern and many more. These are often exaggerated beyond all reason by the urgency and pressures of the situation, thus lowering the efficiency of the overall operation.

1.08 The rescuer must be aware of the psychological needs of accident casualties, not just their physical needs, and be prepared to meet those psychological needs.

RESCUE WORKERS

1.09 An event requiring rescue operations will usually create three categories of rescue workers.

1.10 GROUP 1—SURVIVORS

- a. The immediate reaction of survivors of road accidents, once they have discovered they are not seriously injured is to help others. They usually do not know what to do, but they feel they should do something to assist. The situation where untrained survivors, possibly in some state of shock, attempt to render assistance is a concern.
- b. These good intentions could aggravate the conditions of those being 'helped' to the point where loss of life may be greater than it should be. These same individuals could also be a hindrance, in the way of, and interrupting the functioning of trained rescue teams. Nevertheless, uninjured and slightly injured survivors could well be the only hope of survival for many casualties eg if toxic gases, dangerous chemicals, fire or danger of fire exists at the site of the accident. The first group to commence rescue work at an accident site usually consists of those survivors still physically capable of doing so. The potential for good is enormous but the danger inherent in utilising untrained personnel is equally serious.

1.11 GROUP 2—UNTRAINED PERSONNEL

- a. The second wave of rescue workers is drawn from people either witnessing the event or from the vicinity of the event, drawn to the site by curiosity and, for many, a desire to assist the casualties. Although not quite as emotionally involved as the survivors, the danger inherent in utilising untrained personnel is still a factor which must be considered. On the positive side, they often bring necessary resources with them and can be very effective if they can be brought under control and properly supervised.
- b. Unfortunately, a large number of the 'curious' are just that. They have no desire to help, but just look. They get in the way, shout advice and generally add to the excitement at the site, the very thing that is least needed.

1.12 GROUP 3—TRAINED PERSONNEL

The last group to arrive at the scene are the trained rescuers eg Ambulance, Police, Fire, SES etc. It takes some time for various emergency services to mobilise and arrive at the scene. The quicker they can arrive the less time there will have been for the first two groups to aggravate the situation and create more dangers to surviving casualties and to themselves. Well trained teams will effectively utilise the resources available, to efficiently carry out the necessary tasks.

PERSONAL TRAITS OF THE RESCUER

- 1.13 Rescue work is not an easy task, nor is it glamorous. Certainly not all people are suited to such work. Physical fitness, personality, emotional stability and availability are all factors involved in determining one's suitability.

The following traits are desirable:

- a. **Interest**—Rescuers must have a genuine interest in rescue work.
- b. **Motivation**—Rescuers must be prepared to continually undergo training to maintain a professional standard.
- c. **Dependability**—Lives of casualties and team members rely upon dependability.
- d. **Initiative**—The nature of rescue operations is such that it is often impossible to closely supervise each team member. Each must be able to see what needs doing, and complete the tasks at hand.
- e. **Versatility**—Each situation is unique. An individual must apply a wide range of skills and knowledge to new situations.
- f. **Cooperation**—Rescue work is a team effort.
- g. **Physical Fitness**—Rescue work is physically demanding and often continues for long periods. Physical limitations must be recognised by the rescuer and taken into consideration.
- h. **Leadership Qualities**—Required by all rescuers at various times and to varying degrees. Through capable leadership by trained rescuers, many more untrained personnel may be utilised.
- i. **Control Over Fears (Phobias)**—It is important that rescuers are aware of their limitations. Part of this knowledge consists of being aware of phobias. It is vital that the leader of a rescue team is aware of any phobias among team members.

Note: Some phobias which could seriously affect a rescuer, and which may be identified in training are:

- (1) haemophobia (fear of the sight of blood);
 - (2) acrophobia (fear of heights);
 - (3) claustrophobia (fear of confined spaces); and
 - (4) hydrophobia (fear of water)
- j. **Good Dress and Bearing**—Appearance should instil confidence in others.

PERSONAL BEHAVIOUR

- 1.14** The conduct of individuals provides an indication as to their psychological make-up and personality. The nature of rescue work is such that it is particularly important that personal conduct does not aggravate an already stressful situation. It should assist in creating an atmosphere of the rescue being in competent hands and everything possible being done to rescue and care for the casualties.

1.15 Some of the important general areas of conduct or behaviour are:

- a. **Attitude**—A serious, professional attitude must be maintained to gain confidence and support.

Note: Arrogance and superiority create instant antagonism, while loud talking, joking and horseplay reduce credibility. They create a feeling of resentment and add to the confusion, thus hindering the work. Rescuers who display this type of irresponsible, unprofessional attitude add to the state of anxiety of the casualties.

- b. **Emotion**—Emotions are difficult to control in most circumstances. In an accident, the control of emotions is a very difficult task. However, every effort must be made to prevent adverse emotions from influencing good judgement and competence. Regardless of the excitement and the severity of the incident, the rescuer must be able to remain calm and be sympathetic without becoming emotionally involved.
- c. **Courtesy**—Courtesy, tact and good judgement are vital. If the rescue task is to be completed quickly and effectively, courtesy to all concerned is essential.

THE OPERATIONAL SEQUENCE

1.16 The operational sequence refers to the decision making process. Personnel involved in RAR will be continually assessing, evaluating and re-evaluating the operation from the time of first call through to completion.

1.17 DECISION MAKING

To carry out any task successfully, all rescuers must have an understanding of the decision making process. The following method is one means of ensuring this is done:

- a. **Assessment**—The gathering of information.
- b. **Appreciation**—The method by which the information is processed to the stage of a decision being made. It includes the aim, factors, options, advantages/disadvantages, selected course of action and outline plan.
- c. **Plan**—The outline plan moulded into a formal plan of action, and includes resources deployment.
- d. **Orders**—The delivery of the plan to subordinates and are usually based on the SMEAC mnemonic.
 - (1) **Situation**—Description of the actual situation.
 - (2) **Mission**—A positive statement of what is to be done.
 - (3) **Execution**—The method of the rescue.

- (4) Admin & Log—Administrative and logistic requirements.
- (5) Command & Communications—A positive statement of command and communications details.

SAFETY IN TRAINING AND OPERATIONS

- 1.18** The task of road accident rescue is potentially dangerous to the casualty and the rescuers. Therefore considerable training is necessary. Personnel must observe safety measures at all times and training officers and other supervisors must strictly observe those measures.
- 1.19** Wherever possible, rescuers should adhere to standard techniques and practices in the field.
- 1.20** In any rescue technique, safety limitations and margins have been built in for casualty and rescuer protection. These must never be ignored. must never be ignored.

CHAPTER TWO

PREPARATION

INTRODUCTION

2.01 This chapter forms step one in the systems approach to road accident rescue. It is important that rescuers understand the relationship between each step and its relevance to the overall task.

2.02 The following subjects are covered:

- a. Selection of the Rescue Vehicle.
- b. Types of Rescue Vehicles.
- c. Selection of Road Accident Rescue Unit Equipment.
- d. Readiness of the Rescue Vehicle and Equipment.
- e. Training.
- f. Rescue Team Composition.
- g. Personal Safety.
- h. Correct Lifting Techniques.

SELECTION OF THE RESCUE VEHICLE

2.03 A survey of the local community in regard to specific hazards that may be encountered must be made. Potential hazards must also be taken into consideration. Before obtaining the vehicle/trailer, factors which should be considered are:

- a. present and potential needs of the community;
- b. financial situation relative to obtaining, maintaining and providing the necessary tools and equipment;
- c. continuing future support of its operation;
- d. type and amount of equipment to be carried on vehicle/trailer;
- e. number of personnel to be carried; and
- f. topography of the land and road conditions.

TYPES OF RESCUE VEHICLES

2.04 DESIGN CONSIDERATIONS

When the potential hazards have been assessed, the selection of vehicles can be considered. Consideration of vehicle design should include:

- a. heavy tools stored in a position that requires minimum reaching and lifting;
- b. equal weight distribution throughout the vehicle to maintain low centre of gravity;
- c. location of plant and equipment that is power driven (this should be located so that vehicle motor driven power trains are in line and exhaust from motors are directed to a position that will not infringe on the working of the rescue team);
- d. large enough to hold personnel and equipment;
- e. equipment to be easily accessible, preferably from the outside;
- f. power to weight ratio not to exceed the manufacturer's specifications;
- g. stowage configurations designed in a way to keep equipment secure and visually displayed (where possible);
- h. compartment doors designed to allow full exposure to the equipment but not endanger the rescue team when open; and
- i. sufficient lighting to illuminate incident site.

2.05 STANDARD MODEL VEHICLES

Various manufacturers produce stock models which are designed for carriage of tools and equipment which can readily be adapted with partitionment and flood light systems. These are usually van type bodies with limited personnel facilities. Access to the rescue equipment is limited to the existing openings on the body configuration.

2.06 CUSTOM-BUILT VEHICLES AND MODULES

Custom-built vehicles are designed from the chassis up whilst the modules are designed to fit the cab chassis configuration. Both are specifically designed to locate the rescue tools as recommended. Many effective custom-built vehicles/modules are already in use. Contact with existing rescue organisations may provide plans to assist with a local design. The advantage of custom-built modules is that they allow for a change over of the drive unit with the retention of the rescue module for a greater service life. Modules can also be made to suit dual cab vehicles to allow for additional personnel carrying capacity.

2.07 ROAD ACCIDENT RESCUE TRAILERS

There are circumstances where local terrain or cost factors indicate that a trailer unit would best serve the community needs. The same basic principles apply in respect to weight loading and configuration of the trailer module. An advantage of the trailer type rescue module is that in rural areas they can be transferred from a road type vehicle to a suitable four-wheel-drive or tractor type vehicle for access over more difficult terrain.

SELECTION OF ROAD ACCIDENT RESCUE UNIT EQUIPMENT

- 2.08** Rescue equipment varies from simple hand tools to powered hydraulic sets. A suggested list is attached at Annex A. This list is designed only as a guide and may be added to or subtracted from as local operational requirements dictate. Note: Rescue personnel should refer to manufacturers' instructions for details of care, use, maintenance and safety requirements of rescue equipment.

READINESS OF THE RESCUE VEHICLE AND EQUIPMENT

- 2.09** It is essential that all rescue vehicles and equipment are maintained in peak operating condition. Local instructions will dictate frequency of inspections.

RAR TRAINING

- 2.12** Road accident rescue is an operation demanding skilled, labour intensive activity covering a wide variety of accident situations. Thus, a high level of training is necessary to achieve a rapid, efficient operation. In addition to physical training, an effective call out system needs to be developed and exercised.

Note: Where applicable, State/Territory policy and standards relating to qualifications and accreditation apply.

- 2.13** There can be no doubt that in a local community there exists much expertise that may be utilised for the purpose of RAR. Tradespeople such as panel beaters, motor mechanics, fitters and others are an invaluable resource. It would be an advantage to obtain their assistance in training members of the team.

- 2.14** Most members of other organisations involved in emergency work can provide units with expertise and specialist training in first aid, casualty handling and firefighting as well as lectures on procedures for hazardous materials. It would be remiss of any unit not to take advantage of sources of expertise. One of the most successful ways in establishing a good rapport with Statutory Authorities is to invite them to assist with training and act as umpires on exercises designed to test rescue procedures.

- 2.15** There is no substitute for regular æhands-onÆ training for the team. Sources for appropriate vehicles may be the local wrecker, the local refuse dump, abandoned derelict cars or the Local Authority which removes abandoned vehicles.

- 2.16** Wherever possible, the vehicle obtained should have the majority of glass still intact and include the steering wheel/column, seats and doors.

RESCUE TEAM COMPOSITION

- 2.17** On completion of basic training the unit can be structured to provide an effective personnel response. Considerations for team composition are:
- a. a recognised and qualified team leader;

- b. a qualified driver; and
- c. sufficient trained personnel.

2.18 LEADERSHIP

Whilst there should be a recognised leader at incidents, all persons operating at a road accident rescue must understand the qualities of leadership. In the event of a larger incident, crews may be fragmented, necessitating a leadership role by individual rescuers.

PERSONAL SAFETY

2.18 All rescue organisations supply their members with protective clothing and equipment. Rescuers may be confronted with a variety of hazards, such as:

- a. fire;
- b. hazardous material;
- c. unsafe or unstable locations;
- d. live electrical wires; and
- e. communicable diseases.

2.20 PROTECTIVE EQUIPMENT

Safety is the responsibility of every member. Protective equipment should be worn during all training and operational incidents. The recommended minimum issue of equipment is:

- a. helmet
- b. overalls/coat;
- c. work gloves;
- d. boots;
- e. eye protection;
- f. ear protection; and
- g. disposable gloves.

CORRECT LIFTING TECHNIQUES

2.21 Adoption of correct lifting techniques is essential. Rescuers will be required to lift, haul or push loads, and must be trained to handle these tasks properly and safely.

2.22 AVOIDING INJURY

There is a serious risk of spinal or abdominal muscle injury due to incorrect lifting, and the following points detail correct lifting techniques:

- a. As the leg and thigh muscles are stronger than those of the arms, back or abdomen, it follows that these are the muscles which should be used for safe lifting.
- b. During a lifting operation, the rescuer should crouch down with knees bent, back straight and feet properly placed to bear the load. See Figure 2:1.
- c. Gripping the load correctly, the rescuer should start the lift by the thrust of the legs, and continue this thrust until the legs are straight, keeping the load close to the body and keeping the back straight. In this way, the strain involved is placed on the leg muscles, and the possibility of back or abdominal injury is greatly reduced.
- d. Loads should be lowered in a reversal of the lifting techniques.

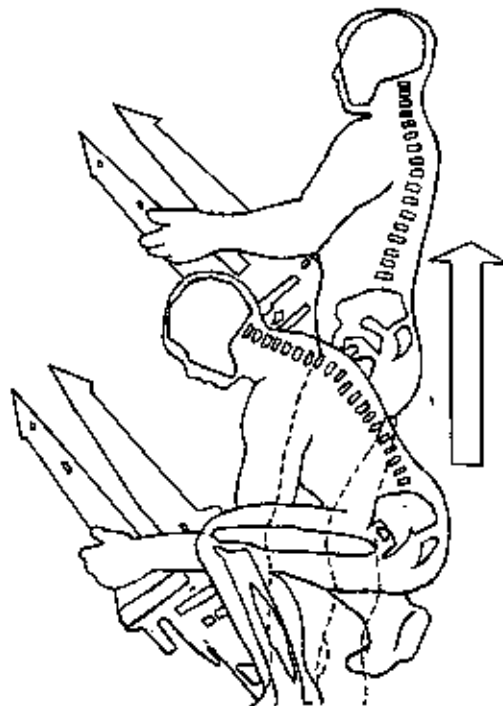

Figure 2:1
Correct Lifting Technique

RECOMMENDED EQUIPMENT

TOOLS	TYPES	APPLICATIONS
AIR BAGS	Various—lifting from 8-70 tonne (high and low pressure)	Lifting, spreading and Sealing
AIR SUPPLY	Compressor or cylinder	Source for Pneumatic Tools, Air Bags, Cylinders
AXE	Conventional, pry and fire	Cutting and prying of wood or metal
BARS	Crow, pinch and picket	Prying, levering and hold fasts
BLANKETS	Woollen, space and fire	Protection and comfort of casualty
BLOCKS/ WEDGES	Unpainted wooden and rubber, step chocks, wheel chocks	Stabilising and packing
BOLT CUTTERS	Various sizes	Cutting metals and cables
BROOM	Yard	Debris removal
CENTRE PUNCH	Impact, spring loaded	Window glass removal
CHAINS	Various	Anchoring, lifting hauling and stabilising
CHAINSAW	Petrol ,electric and hydraulic	Cutting of wooden poles, trees and structure
CHISELS	Pneumatic, hand (cold)	Opening panels, removing bolt heads/nuts
CORDAGE	Various lengths/ diameters	Casualty handling, stabilising and hauling
DISC CUTTER	Petrol, electric, hydraulic	Use is restricted to cutting heavy structural material and/or Glass Reinforced Plastic
DRILL	Electric, hand and pneumatic	Boring various materials
FIRE- EXTINGUISHERS	Water, foam, dry chemical, CO 2	Suppression of fire

TOOLS	TYPES	APPLICATIONS
FIRST AID	Basic kits	First aid to support casualty
GENERATOR	240 volt	Power source for lighting and various tools
HACKSAW	Hand, various blades	Cutting of metal bars, arms, levers, etc
HAMMER	Sledge, mash, carpenter, slide and engineer	Shoring, driving in hold fasts, etc
HAND TOOLS	Spanners/sockets, screwdriver tin snips, stilsons side cutters and insulated pliers	Dismantling and removal of vehicle parts, cutting of electric leads, etc
HYDRAULIC RESCUE TOOLS	Manual/powered	Spreading, cutting, pushing and pulling
JACKS	High lift, mechanical/ hydraulic	Lifting, spreading, and shoring
KNIFE	Clasp/Stanley seat belt cutter	Seat belt, window removal and cutting of clothing/footwear
KNIFE (DRAW)	Glazier's knife	Windscreen removal
LADDER	Extension, folding	Embankments, ramps and high vehicles
LIGHTING EQUIPMENT	Flood, spot, bank, power leads and torches	Scene lighting and searching
PROTECTIVE CLOTHING	Coats, boots, helmet visors/goggles, gloves, overalls/disposable splash suits, ear muffs, reflective vests, communicable disease kit	Rescue operator/casualty protection
RECIPROCATING SAW	Electric/pneumatic	Cutting pillars, panels, columns, arms and levers
SHACKLES	'D'/Bow	Connecting cables, chains/slings
SHEARS	Paramedic	Cutting clothing, footwear, seat belts, etc

TOOLS	TYPES	APPLICATIONS
STEEL ROPE (SWR)	Various lengths and diameters, slings	Holding/stabilising
STRETCHER	Stokes Litter, Ferno Washington, Paraguard, Jordon frame, back board (full and half)	Casualty handling
TARPAULIN	Various sizes	Shelter covering
TORCHES	Battery and rechargeable	Lighting of difficult areas etc
WARNING DEVICES	Lights, vehicle and portable, safety cones, signs	Protection of scene
WATER CONTAINER	Clean water	First aid/welfare
WINCH	Manual/power	Hauling, stabilising

CHAPTER 3

RESPONSE

INTRODUCTION

3.01 As with all emergency service operations, the response procedure to be followed should be defined, so the team has clear guidelines in which to operate.

RESPONSE

3.02 There are three sequential steps in the response:

- a. Receipt of the call.
- b. Travelling to the scene.
- c. Arrival at the scene.

RECEIPT OF THE CALL

3.03 INITIAL ADVICE

At the time of making the call, an informant may be in a distressed and/or agitated condition. Considerable self-control, on behalf of the receiver of the information, may be required to gain as much information as possible regarding the incident.

3.04 EXACT LOCATION

The exact location should be established by requesting the following information, as appropriate to the urban or rural situation. Annex A shows a sample checklist.

- a. Town/suburb or distance and direction from/to nearest town.
- b. Correct street/road/highway name.
- c. Geographic situation; eg Smith Street, west, nearest crossroad.
- d. Prominant landmarks.

3.05 NUMBER OF PERSONS TRAPPED/INJURED

These facts will assist the ambulance service with the medical response and inform rescuers of what they may encounter on arrival.

3.06 TYPE OF VEHICLES INVOLVED

This information is required to determine the resources needed.

3.07 HAZARDS

Hazards are classified into the two categories of:

- a. traffic; and
- b. non-traffic.

3.08 TRAFFIC

The informant should be asked the following questions:

- a. Is the roadway partially blocked?
- b. How many lanes are open?
- c. How busy is the road and is the traffic banked up?

3.09 NON-TRAFFIC

Non-traffic hazards may include:

- a. downed electrical wires;
- b. fire;
- c. hazardous cargoes;
- d. unstable vehicles;
- e. debris;
- f. spilt fuel;
- g. LPG-fueled vehicles; and
- h. bystanders.

3.10 NAME OF INFORMANT AND CONTACT ARRANGEMENTS

Personal details will be required if information is to be verified or queried. Contact arrangements may be telephone/telephone box number, radio mode, channel and call-sign. Telecom can often determine the location of a telephone number without delay.

3.11 INFORMING OTHER SERVICES

After gathering the relevant information regarding the accident, the control centre should alert other services, as required by state/territory procedures. Prompt notification is vital to ensure an early despatch and attendance of the correct response.

3.12 ROAD ACCIDENT RESCUE RESPONSE INFORMATION

If a responding organisation has received all the above information prior to the departure of the response team, the team leader can commence assessment whilst en route. Although experience may indicate that there can

be difficulty in gaining this detail, the receiver of the call must endeavour to gain all the information.

3.13 AIDE-MEMOIRE

Attached as Annex A to this chapter is a suggested Aide-Memoire to be completed by the receiver of the call.

TRAVELLING TO THE SCENE

3.14 THE DRIVER

The driver of the emergency vehicle has a great responsibility, including the safety of the crew, vehicle, equipment, pedestrians, and other road users. The driver must also possess a thorough knowledge of the state or territory road traffic act and regulations, and any limitations of the act or regulations as enforced by their organisation as part of standard operating procedures (SOPs).

CAUTION: Audio and visual warning devices are only aids to emergency driving and do not guarantee right of way. Safety must be a paramount consideration.

3.15 FACTORS AFFECTING TRAVEL TO THE SCENE

These include:

- a traffic volume;
- b. weather conditions;
- c. detours;
- d. road conditions; and
- e. access to the accident site.

3.16 TRAFFIC VOLUME

Higher traffic volumes are expected in and around business areas of a town or city. Alternate routes to bypass the slower commercial traffic may be required. The time of the day will define the peaks in the traffic volume. Social and sporting events, school hours etc may also create artificial peaks in traffic volume.

3.17 WEATHER CONDITIONS

Inclement weather conditions ie rain, fog, hail, ice, will reduce driving speed and increase response times.

3.18 DETOURS

Traffic can be seriously slowed by road/building constructions, repairs to public utilities, floods etc. Detour and lane restrictions can last for varying times from a few hours to several weeks.

3.19 ROAD CONDITIONS

Road conditions should be constantly monitored to evaluate the effect that changing conditions will have on response time. Information such as traffic trouble spots, schools, railway crossings, shopping complexes, detour and lane restrictions should be noted on a daily basis and crews informed of any change.

ARRIVAL AT THE SCENE

3.20 ACCESS

The accident scene may prevent access from a certain direction eg wind blowing hazardous materials, vehicles blocking road etc.

3.21 INITIAL ACTIONS

Accidents need to be approached cautiously, and with careful observation of the entire scene. Potential danger signs need to be noted. The scene of chaos must be put aside, and focussing on limited problems and solutions avoided. As a rescue team is arriving on the scene, three activities must be conducted. They are:

- a preliminary assessment;
- b positioning rescue vehicle; and
- c. situation report (sitrep).

3.22 PRELIMINARY ASSESSMENT

As the vehicle approaches a distance at which the general area can be seen, sirens should be switched off, and a mental note made of any feature in the general area which may relate to the rescue operation such as:

- a. downed powerlines;
- b. spilt fuel;
- c. HAZMAT situation;
- d. unstable vehicle; or e. debris.

3.23 CONCEALED CASUALTIES

Any other feature which may conceal a casualty should also be observed eg:

- a. long grass;
- b. holes;
- c. large diameter pipes;
- d. embankments/cuttings; or

- e. gullies/drains.

At the first available opportunity, a member of the team should search those areas.

3.24 ARRIVAL

By the time the vehicle comes to a stop, its crew should, in the majority of cases, have already completed the initial assessment of the scene. The team leader should have noted the hazards, the most seriously damaged vehicle, whether or not the vehicles are occupied, and the location of the injured persons. All occupants of all vehicles involved in the accident need to be accounted for.

POSITIONING EMERGENCY VEHICLES

3.25 Factors to be considered when positioning vehicles include:

- a. topography of the surrounding area, including bends in the road, crests, etc;
- b. positioning the vehicle, in suspected or confirmed HAZMAT incidents safely upwind and uphill at a distance as specified by state/territory SOPs for HAZMAT incidents;
- c. placing a vehicle in the 'fend off' position to provide protection to team members and casualties (Figure 3:1);

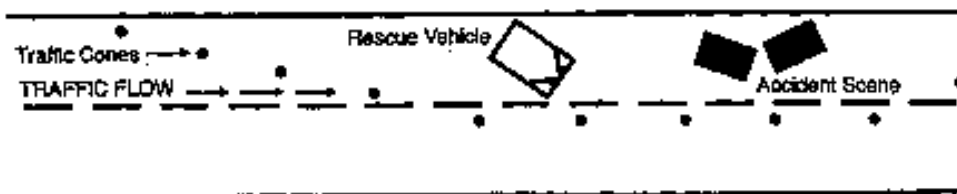

Figure 3:1
Fend Off Position

- e. access and egress of other essential services; e. maintenance of traffic flow;
 - f. preservation of evidence; and
 - g. limitations placed by fixed equipment on the vehicle eg lighting, hydraulic hose lines, etc.
- 3.26 If the vehicle is located some distance from the incident, it is desirable that the assessing member of the team be equipped with portable two way communications to ensure efficient deployment of resources and transfer of information.

SITUATION REPORT

- 3.27** With the preliminary assessment completed, a SITREP should be passed to the control centre. This information enables the control centre to advise, or place on standby, additional resources or other emergency services as outlined in SOPs. SITREPS should be upgraded as required as the operation proceeds.

AIDE-MEMOIRE—RESPONSE INFORMATION

Date/Time

ORIGIN OF CALL

Police (); Fire (); Ambulance (); S/TES () Other

EXACT LOCATION

a. street/road/highway name (include geographic location, nearest cross street etc)

.....

b. town/suburb/distance & direction to/from nearest town

.....

c. dominant landmarks

.....

ACCIDENT DETAILS

Number Trapped () or Injured ()

Type/Number of vehicles involved

Car Truck.....Bus Train..... Other

Time of Accident

HAZARDS

Petrol (); Gas (); Explosives (); HAZMAT (); Fire ();

Debris (); Downed Powerlines (); Unstable Vehicle ();

Other ()

INFORMANT'S DETAILS

a. Informant's Name

b. Current Contact Details Telephone/telephone box number

.....

Radio mode/channel/callsign

.....

c. Informant's Address

CHAPTER FOUR

INCIDENT MANAGEMENT

INTRODUCTION

- 4.01** This Chapter is designed to explain the actions required of a Rescue Team Leader from the time of leaving the vehicle to the commencement of the process of gaining access to casualties.
- 4.02** The actions taken during this time are:
- a. liaison with other services present and carry out initial on scene assessment;
 - b. an Outer Circle Assessment (*);
 - c. an Inner Circle Assessment (*);
 - d. arrange Hazard Control measures as necessary (*);
 - e. arrange Support Functions as required (*);
 - f. establish an Action Circle;
 - g. establish an Equipment Holding Area; and
 - h. establish a Human Resource Staging Area as necessary.
- Note:** The items marked with an asterisk may occur in any order or simultaneously.

ASSESSMENT

- 4.03** Responding rescue team leaders need to have a method of assessment. The following factors need to be considered. Addressing these factors enables the team leader to make a valued assessment on decisions to be made.
- a. **Facts**—A limited number of facts will be known from pre-planning material, SOPs and information gathered on receipt of a call and on arrival at the scene, eg rescue teams standard response, time of day, type of accident and numbers of vehicles involved.
 - b. **Probabilities**—There will be a number of events that probably have occurred. These include people being trapped or injured, traffic and non-traffic hazards, and other services responding.
 - c. **Possibilities**—At any rescue there will be a considerable range of events which may occur, eg changes to weather, fire, loss of responding personnel at the scene owing to injury or other duties.

- d. **Resources**—When making an assessment, the number of personnel and amount of equipment from all sources required to perform the task, should be noted.

ESTABLISHING LIAISON

- 4.04** Close liaison is necessary between all attending services and the combined use of personnel and equipment may be required to safely and efficiently complete the task. Each of the services has authority to perform specific tasks at an incident. Although such lines of authority are clear, there will be times when some of the responsibilities overlap. Close liaison will ensure any tasks are carried out smoothly.

COMMAND POST

- 4.05** At major or extended incidents, consideration should be given to the establishment of a command post on-scene, with representation from all responding services.

Note: The implementation of specific on-scene command/control systems should meet agency/state/territory requirements.

INITIAL ON-SCENE ASSESSMENT

- 4.06** The initial on-scene assessment is the gathering of information by any means and establishes an overview of the incident scene. This assessment must take place before any physical action is taken by the team as a whole and could consist of:

- a. smelling for fuel vapours;
- b. listening for information from witnesses; and
- c. looking for visible hazards.

- 4.07** The importance of continuing the assessment process prior to each individual task throughout the entire incident cannot be over-emphasised.

INNER-CIRCLE ASSESSMENT

- 4.08** To accurately assess the incident scene, rescuers must search around the vehicle(s) at a distance of about 2 to 5 metres. This involves looking in, under, above and around the vehicle to determine numbers of casualties, types of injuries, types of entrapment, hazards involved, access and other potential problems relating to the incident.

CAUTION: Vehicles should not be touched until the possibility of electrocution (eg downed powerlines, traffic light installations etc) has been eliminated.

OUTER-CIRCLE ASSESSMENT

- 4.09** To complete the assessment, rescuers must search an outer-circle area, looking for additional injured persons and/or hazards. This can be made

simultaneously with the inner circle assessment or when other rescue personnel become available. A distance up to about 30 metres from the vehicle(s) is usually required, but greater distances can be required in country areas or if there is evidence of missing persons in the vehicles involved (eg children's toys etc).

Note: If practicable, witnesses or persons involved in the accident should be questioned to assist in determining total numbers of people involved.

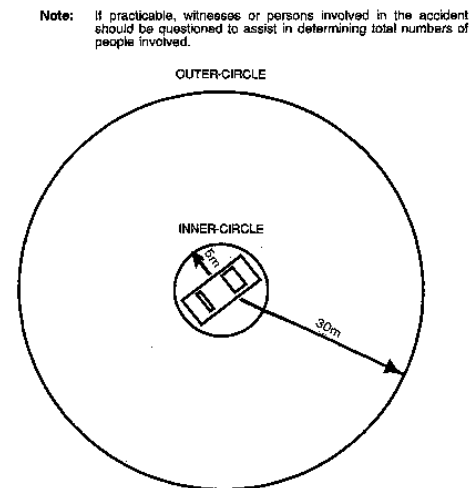

Figure 4:1
Outer/Inner-Circle Assessment

SITUATION REPORTS

4.10 Once the assessments have been completed, a full situation report (SITREP) should be sent to the rescue team's control centre. This enables the team leader to state the current situation for recording, and make any requests for assistance or statements of guidance to other responding personnel.

4.11 The development of a situation report from within a service will enable the rescue team leader to provide for the requirements of that service.

4.12 The type of information which could be passed in a SITREP includes:

- a. scene location and details, eg numbers and types of vehicles and casualties;
- b. hazards present;
- c. action being taken;
- d. support functions required, eg equipment/personnel, specialised services;
- e. estimated time of task engagement; and
- f. specific problems, eg difficult access, removal or transfer.

4.13 Further situation reports should be sent on a regular basis, the frequency of the reporting interval will depend on the team's response requirement.

HAZARD CONTROL

4.14 EVALUATING AND NEUTRALISING HAZARDS

Emergency services personnel can be confronted with many hazards when attending road accident rescue incidents. During the preliminary, initial on scene, outer circle and inner circle assessments, hazards must be identified and prioritised so that they can be neutralised in logical sequence.

4.15 TYPES OF HAZARDS

There are a variety of hazards which need to be considered by rescuers:

- a. **Traffic**—Accidents will usually cause some kind of traffic flow problem. Of the utmost importance is the protection of the accident scene from passing traffic (including the responding services personnel and vehicles). Therefore, police and other emergency service personnel may be required to initiate lane control, detour or blockade measures to ensure scene protection is maintained as follows:
 - (1) **Placement of Warning Devices**—At vehicle accidents, traffic cones, flashing lights, signs and other similar warning devices are used to alert on-coming traffic. Crews should place warning devices so that on-coming traffic will be able to see them, and be able to react with a margin of safety. Factors that must be considered include:
 - (a) road topography;
 - (b) posted speed limits;
 - (c) required stopping distances for vehicles;
 - (d) traffic volume; and
 - (e) weather conditions.

Suggested distance for the placement of the farthest warning device from the accident scene is 1.5 times the posted speed limit, in metres.

Posted Speed Limit (kph)	Distance of Farthest Device (metres)
60	90
70	105
80	120
90	135
100	150

110	165
120	180

Distances in this chart are formulated from the stopping distance for three-axle trucks and semi-trailers.

- (2) Traffic Control—The diagrams which follow show some methods of traffic control to ensure scene safety.

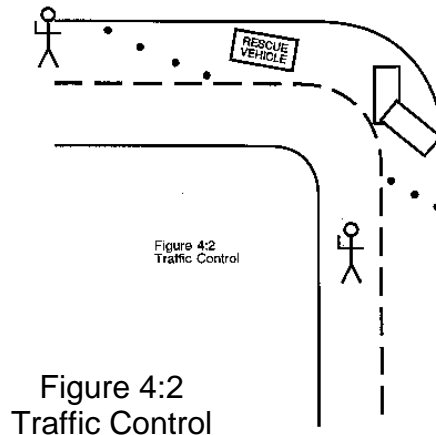

Traffic control measures must be placed an adequate distance from each side of the scene to ensure the traffic flow is taking the required path and at a suitable speed past the accident scene.

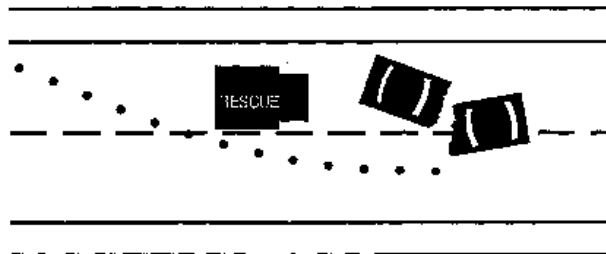

b. **Vehicle Instability:**

- (1) All vehicles need to be stabilised prior to rescue operations. A vehicle on its side, roof or on sloping terrain is a danger to the entrapped person(s) and the rescuer. Failure to ensure a stable working platform can result in further injury to the casualty, especially when spinal or severe injuries have been inflicted in the initial accident.
- (2) Stabilisation techniques may include placing under the vehicle wooden blocks and wedges, jacks, cribbing or any other materials found at the scene, eg spare wheel, posts etc.

Care should be taken to use materials which provide friction between the surfaces, eg unpainted wood or similar.

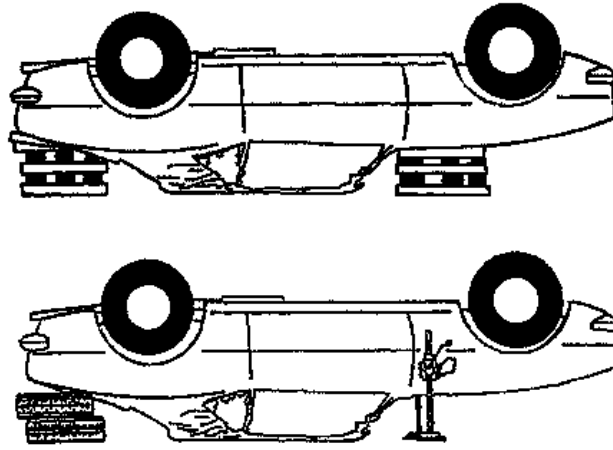

Figure 4:4
Vehicle Stabilisation

- (3) It may be necessary to deflate the tyres of the vehicle allowing it to settle onto the chocking creating a stable working platform, especially for severe spinal injury situations. (Note that this action will remove the option of moving the vehicle by pushing). Continual checking of the stabilisation and vehicle integrity should be undertaken throughout the rescue operation.
- c. **Fire**—The potential of fire at vehicle accidents is always present when fuel leakages occur. Adequate measures must be taken to ensure fire protection is present at all times. A charged, manned hose line from a fire appliance or suitable fire extinguishers should be on hand ready to use.
- d. **Vehicle battery**—a hazard may be caused by a battery being left connected. arcing of wiring may cause ignition of fuel and other combustible materials. in most cases disconnection of the vehicle battery is required. this may be accomplished by removing the earth cable first.

Note: The use of water/CO₂ spray when disconnecting the battery minimises the chance of ignition of flammable materials from electrical arcing.

CAUTION: The use of CO₂ may cause frostbite on exposed skin.

REMEMBER: THE VEHICLE BATTERY MAY BE REQUIRED TO POWER ELECTRICAL SYSTEMS (EG CENTRAL LOCKING DEVICES, ELECTRIC SEATS AND WINDOWS).

Some car alarm systems may be activated if the battery is disconnected. Most alarms can be cancelled by depressing the electronic control key, or by reconnecting the battery if this is not available (eg stolen car).

- e. **Fuel**—Where gas or liquid fuel spillages have occurred, dispersing, neutralising with an agent, or covering should be accomplished as soon as possible. Flushing flammable fuels with water does not completely eliminate the risk of ignition and may compound the problem when

allowed to flow into drains etc. Ruptured fuel lines can be crimped to stop further leaks and holed fuel tanks may be plugged with leakage putties, soap, matting in conjunction with air bags or cone shaped wooden or rubber plugs.

REMEMBER: DO NOT USE ANY PLUGGING METHOD WHICH MAY CAUSE SPARKS.

Note: Rescue personnel must be aware of the various types of valves and pipe systems to be able to render safe Liquefied Petroleum Gas (LPG) and Compressed Natural Gas (CNG) powered vehicles.

- f. **Electricity**—downed powerlines are a common occurrence when vehicles collide with electrical installations. all persons should be kept clear until the electrical source has been isolated. persons still in vehicles which are in contact with live powerlines must be warned to stay in the vehicle and not to touch any part of the metal body. reassure the casualty from a safe distance and notify the local power authority to disconnect the supply immediately. **Treat all electrical conductors as live.**
- g. **Communicable diseases**—rescue personnel who may come in contact with body fluids and tissue must be aware of the possibility of contracting an infectious disease. the wearing of protective clothing, goggles/glasses, masks and rubber surgical gloves under normal rescue gloves will give the rescuer protection. (refer to chapter 6 annex c, for details).
- h. **Hazardous Materials (HAZMAT)**
 - (1) Many hazardous materials are transported by road. These include:
 - (a) explosives;
 - (b) poisons;
 - (c) radioactive materials;
 - (d) infectious substances;
 - (e) unstable (reactive) chemicals; and
 - (f) cryogenic liquids/gases.
 - (2) HAZMAT Responses:
 - (a) When these materials are accidentally released or exposed to fire that results from an accident, they may severely endanger the lives and health of road users, occupants of nearby buildings and emergency services personnel that respond to the scene. In some cases a release into, or exposure to, the atmosphere may have similar effects.

- (b) Fire services are equipped to handle hazardous materials and must be notified as soon as possible.
- (c) Identification of a hazardous material without protective clothing and breathing apparatus should not be attempted. If there is an urgent need, identification must be made from a safe distance upwind and uphill of the incident. No contact should be made with the material. Evacuation of the area should be considered.

SUPPORT FUNCTIONS

- 4.16** Support can best be described as the services or functions which may be carried out in conjunction with and as support to the primary function, eg the lifting of a heavy object to enable rescuers to gain access to casualties.
- 4.17** The decision as to who will provide specific forms of support to meet each function is established by emergency plans and systems OR determined by liaison on site.
- 4.18** At a road accident the primary activity is usually an extrication effort, and many of the rescue team members will be busy with this activity. Other team members/services may have to support the extrication by providing other support functions.
- 4.19** Determining what support activities are required at the scene is an extension of the rescue team leader's assessment and must cover what, where and when support is required and who will provide it. The request should be made through the appropriate authority.

4.20 CONSIDERATIONS

Some major considerations for support are:

- a. **Personnel**—When confronted with a major vehicle accident that requires long term operations or an extended effort, extra rescuers and relief personnel may be necessary.
- b. **Fire/HAZMAT Protection**—Requests for fire appliances should be made according to the needs—different situations may require different equipment, some of which may be available from other organisations.
- c. **Scene Security**—Bystanders must not be allowed to interfere with rescue activities and a barrier of some kind, eg rope or tape, may be required to keep them at a distance from the scene. All rescue personnel should assist the police with security of the scene to prevent theft. Any thefts must be reported to police immediately. Location of personal property must be brought to the attention of the police.
- d. **Utilities**—Water, electricity and gas supply authorities may be required to attend an incident to deal with their own facilities. Their vehicles also carry a wide range of equipment which can be used to assist in rescue tasks.

- e. **Communications**—If a large number of personnel/organisations are on the scene, or the incident is in a remote location, adequate links and facilities should be considered, such as mobile telephones and other organisations' equipment.
- f. **Medical**—The rescue personnel may have to consider requesting further medical support. This may consist of ambulances or in the case of a major incident, hospital triage teams.
- g. **Heavy Lifting/Haulage Gear**—For large-scale transportation incidents that involve trucks, buses or trains, special heavy lifting and haulage gear can be useful and may be available from local authorities, statutory organisations, suppliers and passing traffic.
- h. **Transport**—Specialised transport such as buses, helicopters, boats, and debris removal vehicles gives the responding teams a useful capability and should form part of resource lists.
- i. **Stock Control**—Stock-carrying vehicles involved in a road accident may present rescue teams with problems such as injured animals or stock roaming near the scene. Local authorities and police will be required to destroy injured animals. Assistance may be required to muster stock and remove from the area.
- j. **Welfare agencies :**
 - (1) **Casualties**—Welfare Agencies may be required to take care of displaced persons, upset or grieving relatives.
 - (2) **Rescuers**—Critical Incident Stress debriefing teams may be required to attend to the needs of responding emergency services personnel. (Refer Chapter 9).
 - (3) **Catering**—Catering arrangements should be considered to provide sustenance to staff.
- k. **Information/Media**—The media may be called to assist in advising the public of necessary evacuation warnings or alternate routes to be followed.

ACTION CIRCLE

- 4.21** When undertaking rescue, an area approximately 3 metres in radius should be kept clear from around the vehicle(s). This is to provide a clear work area and should be kept clear of excess personnel, tools and debris. Debris and vehicle components should not be moved without permission of the police unless necessary to carry out the rescue.

EQUIPMENT HOLDING AREA

- 4.22** This area is set up by marking with tape or laying a groundsheet, upon which equipment needed can be placed or located. This area should be adjacent to the 'Action Circle'.

HUMAN RESOURCES STAGING AREA

4.23 Rescuers who have not been tasked, or have completed work should stand in an area adjacent to the equipment holding area. This keeps the action circle clear and indicates to the rescue team leader the personnel available for tasking.

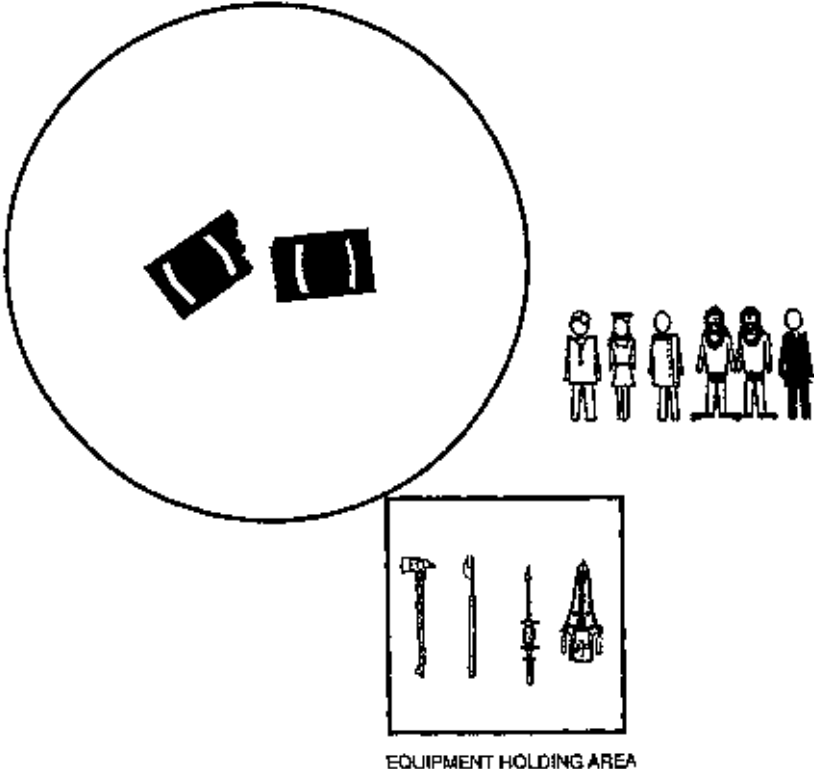

Figure 4:5
Action Circle

CHAPTER 5

GAINING ACCESS

INTRODUCTION

- 5.01** Gaining access is the action taken to provide an opening or path large enough for emergency personnel to reach the casualties and perform life support activities and provide emotional support.

EMOTIONAL SUPPORT

- 5.02** Prior to considering the activities involved in gaining access, rescuers need to be aware of the potential for emotional disturbance of casualties when they realise they are trapped. They can become even more disturbed as rescue methods employed to alleviate their situation develop. Panic can result, increasing the difficulties involved in effecting extrication.

5.03 PERSONAL CONTACT

A person may reject or even physically resist all attempts at assistance. Conversely, they may grasp at their rescuers and fight to pull themselves free. This condition may worsen existing injuries and could also inflict emotional or physical injury to rescuers. In such cases, muscles and tendons of the casualty's body are taut and virtually immobile. Whilst the casualty is in this condition, it is difficult to manipulate the body extremities, an essential step for a safe release. To assist in alleviating this situation, personal contact with the casualty needs to be established. This will assist in gaining confidence which reduces panic and results in a much more relaxed casualty.

5.04 VOICE CONTACT

Voice contact on a first name basis should be made. This assesses the conscious state of the casualty and opens an avenue for communication on a personal level. All communications with the casualty should be positive and reassuring. Note that there will be occasions when a casualty can hear, but will be unable to respond.

- 5.05** The casualty must be informed of the progress of the release, including warning of the action/noise of rescue equipment prior to its operation.

5.06 CASUALTY CONFIDENCE

Where possible and safe to do so, the rescuer should be within the vehicle, giving confidence to the casualty.

- 5.07** On completion of patient assessment, if at all possible, the casualty's hands should be released. Any blood or other matter which may be obstructing their vision should be carefully removed. If the head requires bandaging, the bandage should preferably not obstruct vision.

5.08 CASUALTY COMFORT

Where time permits, an attempt to alleviate discomfort should be made. This may require projections or broken glass to be covered with padding or clearing away. The resultant degree of relative comfort will assist in gaining the trapped person's confidence.

VEHICLE CONSTRUCTION

5.09 Before rescue crews can gain access, they need to understand the basics of vehicle construction, which can vary considerably between manufacturers.

5.10 COMPONENT MATERIALS

Most modern manufacturers construct motor vehicles using the production line method, with assembly taking a matter of minutes. Materials such as sheet metal, plastics, vinyl, rubber, foam rubber, leather, glass etc are all used.

5.11 Sheet metal is folded, bent or welded to a frame to give it strength. Softer materials are used for padding, trim and cosmetics. Tubular metal sections are often used in the framing of seats, along with foam rubber and vinyl or leather.

5.12 It is the task of the rescuer to be able to identify these materials and know their strengths and weaknesses, including materials with the capability to store considerable energy, with the potential to cause serious injury if this energy should be released. Rescuers will need to formulate an effective plan to disassemble, push back into shape, or remove materials from around the casualty, to allow access and permit extrication.

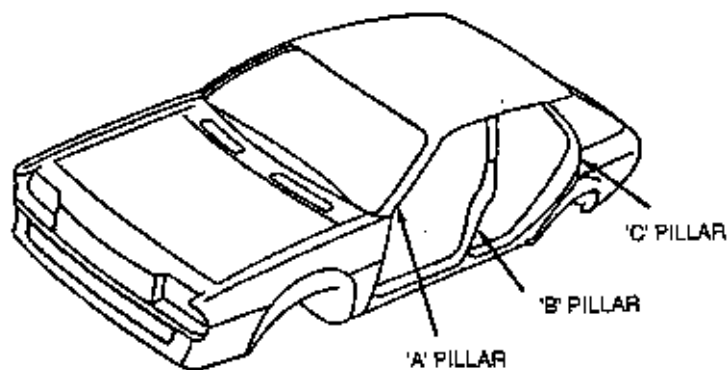

Figure 5:1
Roof Support Pillars

5.13 PASSENGER CARS

The modern motor car is usually constructed by using the monocoque or 'one integral body\frame' process. Some cars have a combination monocoque\subframe body\frame, but this type of vehicle does not have a chassis as such. When involved in an impact, they tend to crumple and cause doors, bonnets and boot lids to be extremely difficult to open or move. The windscreens of some modern models of this type of motor vehicle can provide a significant degree of structural integrity to the upper parts of the vehicle.

- 5.14** Later models have an intrusion bar mounted inside the door panels. This is intended to enhance passenger compartment integrity.

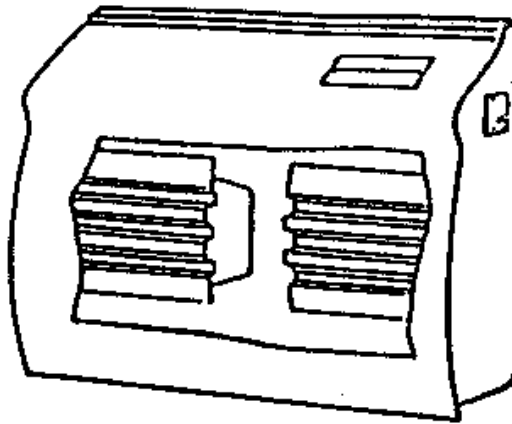

Figure 5:2
Intrusion Bar

- 5.15** Many early motor vehicles use conventional chassis and body construction. This consists of a ladder chassis with two rails running the length of the vehicle. They are joined by substantial cross members upon which are mounted engine, transmission, differential and suspension followed by the body which can be removed or replaced fairly easily. This method of construction usually means greater weight and is not as prone to crumple as in the monocoque type.

5.16 IN-BUILT SAFETY SYSTEMS

In accidents involving early model vehicles, the steering column was frequently driven into the abdomen\chest area of the driver's body. To reduce this type of impact injury, many cars now have collapsible steering columns, seat belts and air bag systems. Further information on seat belts and air bags can be found in Annex A to this Chapter.

5.17 PASSENGER VANS

Forward control vans are of the monocoque style with the potentially hazardous feature of driver and passenger having their feet against the front panel of the body. In a head-on collision, very little protection for feet and legs is provided. In this type of vehicle, wrap-around of the feet\legs by metal panels is common. The problems associated with this particular difficulty are addressed in the chapter on disentanglement.

5.18 UTILITIES

Single cab utilities present a specific problem to rescuers. If the cabin is crushed or semi-crushed, access is difficult because of the restricted space.

5.19 FOUR-WHEEL-DRIVE VEHICLES

Four-wheel-drive (4WD) vehicles, almost without exception have a ladder chassis\separate body construction. Some body types present the rescuer with special problems. Some earlier model 4WD vehicles do not have built-in roll-over protection except as an after-market 'add on extra'. In the event of a

roll-over, vehicles may be crushed to window sill level. Even if they come to rest on their wheels, occupants are likely to have serious injuries and rescuers should expect access problems.

GAINING ACCESS FOR FIRST AID

5.20 No activity should occur until the vehicle(s) are stabilised. Nevertheless, at the earliest opportunity, efforts should be made to assess injuries and priorities so that first aid treatment can commence.

5.21 Treatment of casualties is maintained throughout the entire operation up to the point that hand-over and transportation commences.

- Notes:**
1. All rescuers should wear protection for eyes, hands, feet and body. Additionally, every effort should be made to protect the casualty.
 2. At no time should casualties be left unattended.

5.22 Gaining access for first aid may be a totally different operation to the disentanglement of the casualty or casualties and their extrication or removal.

5.23 A full backboard may be used by first aiders to gain access.

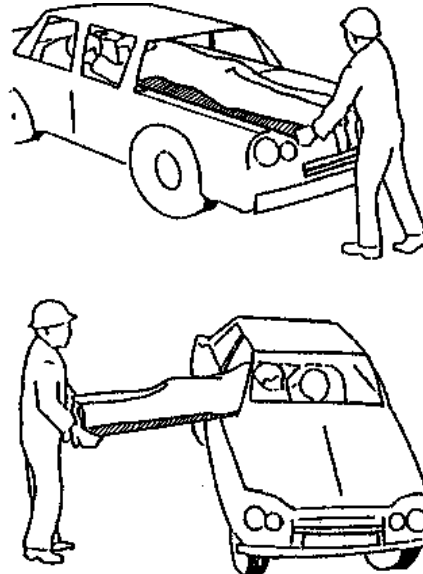

Figure 5:3
Use of Backboard

DOOR ENTRY

5.24 Initially, an attempt should be made to open the doors in the normal manner. All doors need to be checked as one may not be jammed or locked. Similarly, a vehicle occupant may be able to open or unlock the door.

5.25 When a door is jammed, it is unlikely that forcing with crowbars and hand tools will be successful until the safety lock is released. If the door is crushed or the vehicle is a late model, it is nearly impossible to force the door open without hydraulic tools. The most powerful and versatile unit for forcing doors is a powered hydraulic rescue spreader. However, its use requires an initial opening to be established. A crowbar or other similar tool between the door and the doorframe (at either the back or the hinged side) is used to make room to insert the tips of the spreader.

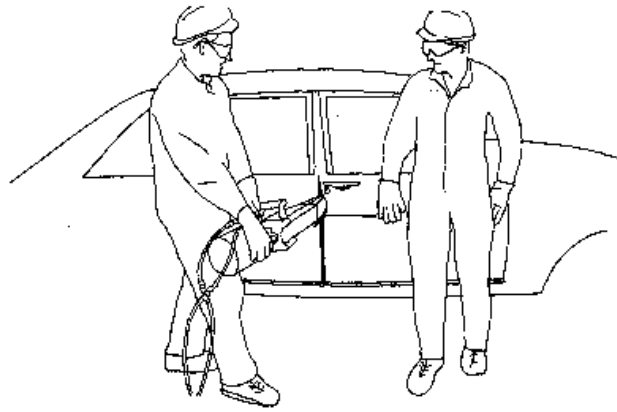

Figure 5:4
Opening Door With Spreader

- 5.26** An alternative method of providing a gap between the door and the pillar is to position a hydraulic tool vertically in the door window. Operation of the tool will force the upper doorframe upward and push the window sill downward so that a sufficiently wide gap is created to allow insertion of the tips at the hinge or lock. One method is to use hydraulic tools in pairs—as one is spread, the other can be repositioned. If only one tool is available, a wooden block can be used to hold the gap open until the tool can be repositioned.
- 5.27** The strongest part of door is within the limits of an imaginary triangle between the hinges and lock mechanism.

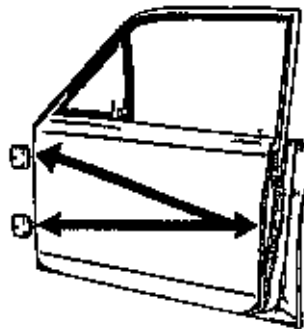

Figure 5:5
Opening Damaged Doors

- CAUTION:**
1. The use of long large bars can rock the vehicle considerably causing severe discomfort or further injury to persons trapped inside.
 2. When using hydraulic equipment, one rescuer should keep weight against the door being opened. At the same time, the door latch is held open.

GLASS MANAGEMENT

- 5.28** Initially, breaking glass for access is to be avoided. Prior to removing or breaking any glass, care must be taken to protect the occupants of the vehicle. If occupants are conscious and able to communicate, they may be able to wind a window down or unlock a door. Two types of glass in common use today need to be considered if breaking of glass is unavoidable. These are as follows:

- a. **Laminated**—Two sheets of glass are joined by a sheet of plastic. This glass typically does not shatter. Shards of glass are retained by the plastic in between the layers of glass.



Figure 5:6
Laminated Glass

- b. **Heat-Tempered**—A single sheet of glass is subjected to high temperatures and annealed like a sheet of steel. Tempered glass has a high resilience and can survive a roll-over. When broken, heat tempered glass shatters into many small segments of irregular shapes about the size of a pea.

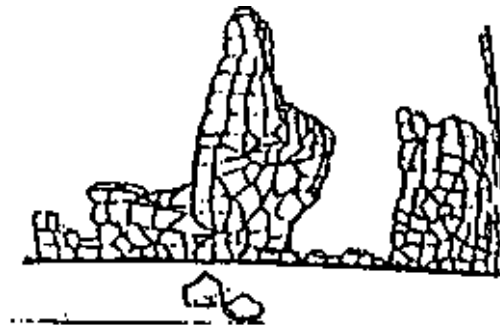

Figure 5:7
Tempered Glass

5.29 LAMINATED GLASS

The following points should be noted when dealing with laminated glass:

- a. The two common methods of securing laminated glass are:
- (1) rubber mounting; and
 - (2) bonded.
- b. If the only access is through a fixed laminated windscreen, the problem of removing/breaking the glass presents itself. There are a number of ways of removal of this type of glass. Options include:
- (1) a windscreen removal knife ('cold knife');

- (2) a glazier's knife;
- (3) braided piano wire;
- (4) specialist electric or air driven windscreen tools;
- (5) diamond wheel grinder;
- (6) a controlled cut with axe or hammer; and
- (7) a bailing hook.

NOTE: Most specialist electric or air driven windscreen tools and braided piano wire require additional access as they are designed to work from the interior of the vehicle.

- c. **Removal of Rubber-Mounted Windscreens**—After removal of windscreen wipers, rubber strips, and any dress mouldings of chrome, stainless steel etc, a sharp knife such as a locking blade knife, lino knife or trimming knife is used to cut the rubber mounting. The whole panel of glass may then be lifted away by two rescuers.

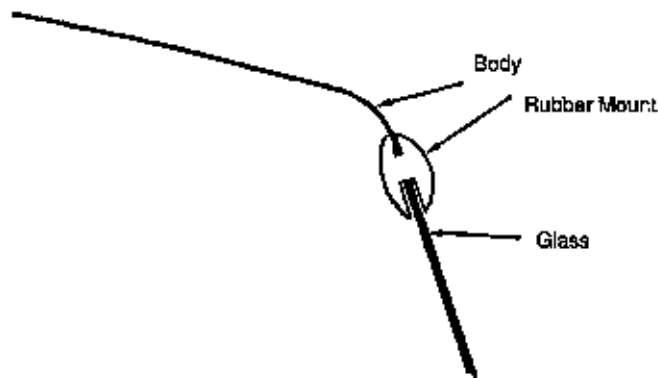

Figure 5.8
Rubber Mounting

- c. **Bonded Windscreens**—A glazier's knife (used by many panel beaters) may be used. It is a bent bladed knife held in a handle and pulled by a toggle attached to the knife handle by wire. It is inserted behind the glass and then run around the perimeter of the glass. A screwdriver or small flat motorcycle tyre-lever can then be used to carefully pry the glass away from the vehicle's body and removed.

Note: Be aware that the removal/breaking of bonded windscreens fitted to some vehicles may reduce the structural integrity of the vehicle.

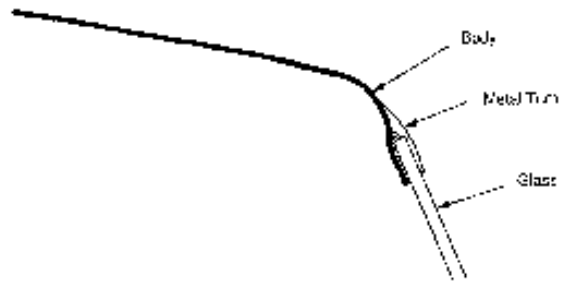

Figure 5:9
Bonded Windscreen

ROOF ENTRY

5.30 When entry is not possible through doors or windows, access through the roof may be required. Depending on access, several options exist for removing a vehicle's roof. Probably the easiest is to cut the 'A' and 'B' pillars, make two cuts in the roof just forward of the 'C' Pillar, and then fold the roof back just forward of the 'C' pillar. Before this is done, the windscreen glass should be removed or broken as described in Chapter 5—'Gaining Access'.

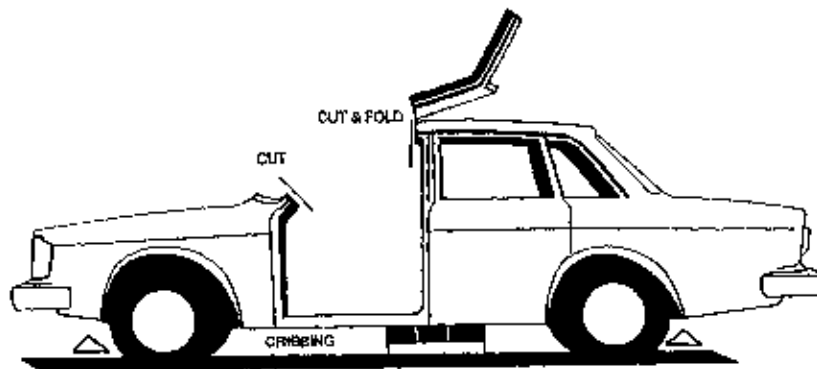

Figure 5:10
Half Roof Hinge

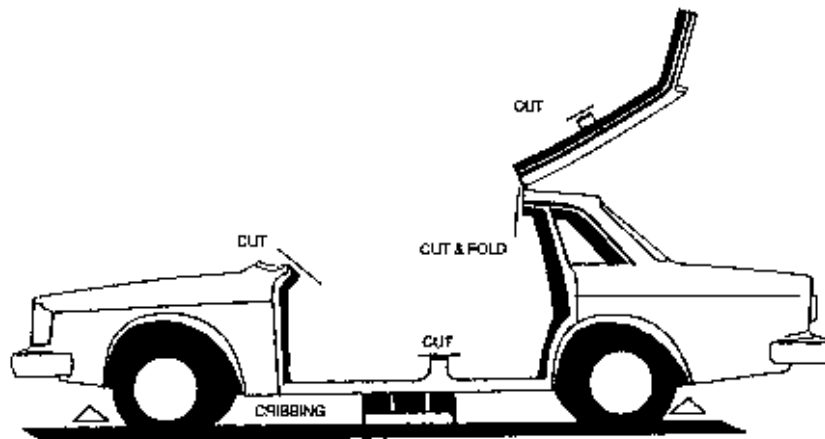

Figure 5:11
Full Roof Hinge

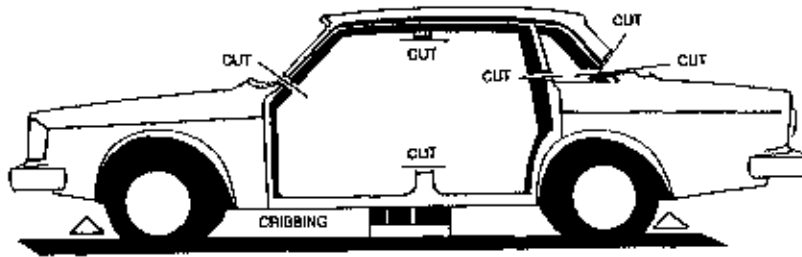

Figure 5:12
Roof Removal

Note: The seat belts will have to be cut in order to raise the roof, as the upper belt support bolts are usually located high on the pillars.

CAUTION: The barrel of the inertia reel seat belt mechanism if cut, may disintegrate releasing a steel spring under pressure.

5.31 CASUALTY PROTECTION

A further consideration is that if the casualty is in a vehicle which is upside down or on it's side, the release of the seat belt could cause added serious injuries if the casualty is not properly supported. Rescuers need to think carefully before cutting the seat belt or operating the release.

5.32 The preferred method of gaining access in the event of a vehicle being on its side is to cut the A, B and C pillars on the upper side, and make relief cuts on the lower side. After cutting seat belts, simply bend the roof down to the ground.

CAUTION: Extreme care must be exercised when cutting roof or floor panels in case casualties are lying against panels being cut.

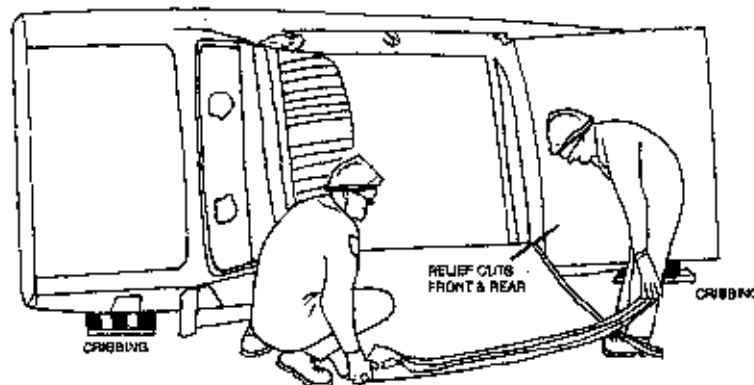

Figure 5:13
Roof Fold Down

5.33 Another method is to make a three-sided cut. Tools used could be panel cutter and hammer, air chisel or 'can opener tool'. The preferred tool is the can opener because it is silent, very controllable and relatively fast. All the other tools are noisy and with the exception of the air chisel, much slower in operation.

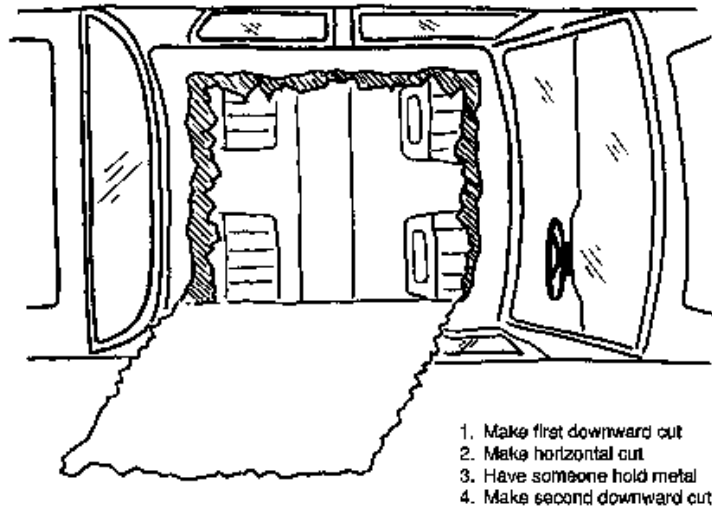

Figure 5:14
Entering Through the Roof

- 5.34** The same hole may be needed for extrication purposes and therefore the cut should be made where possible to leave a smooth, rounded surface. Padding should be provided around remaining jagged edges.
- 5.35** Once the roof panel has been folded back and secured, insulation material and hood lining and support brackets for cabin lights are usually revealed. Heavy gauge wire is often used as support for hood linings and this can be readily twisted out of the holes into which it is placed as the hood lining is cut away with a sharp knife. The light support bracket will need to be cut with a hacksaw or air chisel. Note: Some vehicles have a roll bar incorporated in the roof structure. It is better to cut the panels around these bars as they are substantial and difficult to remove.

BOOT ENTRY

- 5.36** If other access is not possible, the boot area provides a possible route for access. In any event, the boot should be inspected to ensure casualties are not missed.
- 5.37** Some rear seats may be removed by pushing with the feet from the boot area. Alternatively, an opening may have to be cut through the back seat.

CAUTION: Remember fuel and LPG tanks may be installed in the boot area and can hinder access.

FLOOR ENTRY

- 5.38** When a vehicle is in such a position that entry cannot be achieved by other means, it will be necessary to enter through the floor. Structural members and the drive train will dictate the best entry point in relation to the casualty. Only limited access will be possible in most cases.
- 5.39** Using an air chisel or similar equipment, a small hole is cut in a suitable panel to ensure no contact will be made with the casualty. The hole is then enlarged to a size suitable for a work area to gain access to the casualty. Assistance to the casualties in the shortest possible time is essential so that treatment and stabilisation can begin.

CAUTION: Remember when entering through the floor area that hazards may be present. These include:

- (a) fuel and LPG/CNG lines;
- (b) electrical wiring looms; and
- (c) hot catalytic convertors in the exhaust system.

BUSES/COACHES

5.40 Even though coaches differ in individual body design, they are built to comply with specific rules governing construction and safety requirements. They may differ due to individual body designs, independent buyer's requirement, different internal fittings, materials used, electrical fittings, suspension, types of windows, rest rooms etc.

5.40 There are three main classifications body builders use to describe tourist coaches:

- a. Single Deck.
- b. High Deck (Both 'a' and 'b' classified as single deck).
- c. Double-Deck.

5.42 EMERGENCY EXITS

Types and operation of emergency exits vary from coach to coach but all must have at least three means of egress.

BUS/COACH ALTERNATIVE ACCESS

5.43 DOORS

Normal entrance/exit doors can be used as access if the vehicle is upright or has rolled to the driver's side. A second access door is provided in double-deck and many of the tall (high deck) luxury tour coaches and express coaches. The majority of doors on coaches are air operated. In an emergency air supplying the door must be turned off before it can be manually opened. An external dump valve needs to be located and are normally found under the skirt, under the front bumper bar or behind a hinged front number plate. In some coaches, the valve can be found behind a hinged door located on the outside of the coach near the side door. The dump valve actuator can take the form of a valve with a handle or toggle switch that electrically operates a valve. Another dump valve type may have a push button on the outside of the door itself.

5.44 DOOR AIR VALVES

Most city buses and some coaches have dump valves on the inside of the vehicle adjacent to the doorway. These valves release the air pressure and allow the door to be manually opened.

Note: In some systems, the vehicles electrical circuit is required to operate dump valves.

5.45 REAR WINDOW EXITS

The usual means of providing a rear emergency exit has been to install the rear window glass in a simple 'H' rubber section with locking key rubber. Whilst the rubber remains in a pliable state, the glass can be removed (pulled out or pushed in). Problems in this system may include the following:

- a. The window glass tends to float in situ, with a tendency to cause water leakage and corrosion of the vehicle frame and panelling. An owner's common solution to the water leak problem is to seal the area with a silicone type sealant. Unfortunately this repair action makes window removal difficult.
- b. The 'H' rubber section has a tendency to harden over a period of time due to exposure. As the rubber hardens it becomes less pliable with the result that it is difficult to remove.

5.46 REAR WINDOW VARIATIONS

The rear emergency exit has been referred to as a window glass. However it should be noted that as well as glass, other materials can be used. These include:

- a. armourfloat glass (toughened glass);
- b. laminated glass;
- c. perspex;
- d. timber;
- e. fibreglass; and
- f. aluminium.

Note: Many buses and coaches have high back seating installed which could hamper access through the rear emergency exit of the vehicle. For this reason the back rest of the seat (known as the squab) will be held by quick release clips which permit the squab to be either folded down or otherwise completely removed

5.47 EASY-RELEASE WINDOWS

Some late model commuter buses which have recently been released onto the Australian market, feature a new design of rear emergency exit. The rear window is set into a carrier which is bonded to the rear panelling of the vehicle. The window glass can be easily pulled out of the carrier frame.

5.48 WINDOW HANDLES

To aid removal of the rear emergency exit, handles are situated on the outside, usually at the lower corners. Others may be situated nearer to the

centreline of the window. Coaches fitted with a toilet/wash facility usually have no rear emergency window exit installed.

Note: There have been vehicles imported into Australia that feature a variety of rear emergency exit systems, including special doors and/or windows with a variety of locking mechanisms.

5.49 SIDE EMERGENCY EXITS

Depending on the type of bus or coach (its particular design and style), the arrangement of a side emergency exit may be provided in a variety of ways.

5.50 SIDE WINDOW EMERGENCY EXITS

If there is no rear emergency exit, an emergency exit window is usually situated on the off-side (drivers side) towards the rear. Many coaches have emergency side window exits fitted to both sides of the vehicle. Handles are fitted to aid removal. Some buses have handles that swivel or will allow the window to fall out or hinge open whilst others have screw-in handles which will shatter the glass and cause it to fall away.

5.51 OTHER WINDOWS

All windows in coaches should be looked upon as potential emergency exits. In an emergency situation one side emergency exit may prove insufficient for the rapid evacuation of trapped passengers. It should be noted that a window is the weakest area of a bus side structure and therefore is the most likely area to gain access by removing the window glass. The front windscreen, once removed, offers a large opening for access.

5.52 THROUGH THE BODY

If entry is required to be cut through the bodywork, the most accessible locations for this type of entry are as follows:

- a. Through the roof, between the roof bows. The bows can be identified by the rows of rivets with the distance between the bows usually being 1200 mm.
- b. Through the vehicle body panelling around the rear emergency exit window where there is little in the way of internal structural framework. If there is difficulty in removal of the exit panel, intentional deformation to the surrounding panelling will assist in removal of the exit panel.
- c. In an area between two side window frames, immediately below the window. The panel needs to be cut out as near to the floor level as possible. Access through this area will encounter more steel framework than through the roof structure.

CAUTION: When cutting above the top of the window line or near the air conditioning unit (usually fibreglass) be aware of air conditioning lines as they carry gases which will be dangerous if inhaled.

5.53 FLOOR HATCHES OR THROUGH THE FLOOR

Buses and coaches have both metal and timber floors, with floor hatches in certain areas to provide access to various parts. Entry may be made through the floor hatches or floor where possible. The best place to cut through the floor is in the centre of the vehicle between the chassis rails from the luggage bin.

5.54 LUGGAGE BIN LOCATIONS

Where the engine is centre-slung between the chassis rails, the luggage bin will be found at the rear. Where the engine is mounted at the rear, the luggage bin is located in the centre of the vehicle between the front and rear wheels.

5.55 LOUNGE HATCHES

Some newer vehicles now have a lounge area in the rear of the vehicle under the main passenger area. These lounge areas have internal and external entries. Some later model double-deck coaches are fitted with an access hatch between the luggage compartment and the passenger area. This hatch is usually located beside the toilet on the near side wall panel above the first stair landing. If no hatch is fitted, this panel can be cut to give an adequate opening.

5.56 COMMON ROOF HATCHES

There are usually two roof hatches provided in most modern coaches. The centre lid section of a roof hatch is normally a moulded acrylic (perspex) although some previous designs have featured fibreglass. The centre lid sections are typically mounted in 'H' rubber and can be pushed outward or inward. These hatches are quite flimsy in their centre sections and can be dislodged from their mounting rubbers.

5.57 ROOF HATCH VARIATIONS

Some imported vehicles have alternative methods of roof mounted emergency exits. One of these features a twist handle method of opening with a hinged lid.

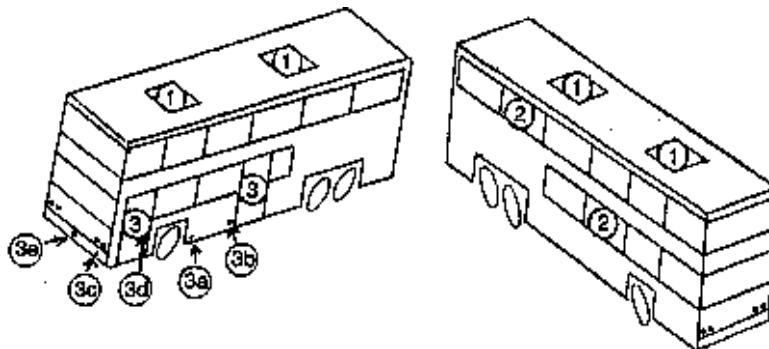

Figure 5:15
Emergency Coach Hatches

5.58 TYPICAL EMERGENCY ACCESS POINTS

Typical emergency access points appear in Figure 5:15 as described and cross-referenced below.

- a. Push-in, push-out roof hatches. (see 1 in Figure).
- b. Pull-out/push windows on vehicle. These are clearly marked. (see 2).
- c. Doors (pneumatically controlled—see 3)—To open in emergencies, and depending on the type and make of the vehicle, open hinged flap to locate the dump valve. This valve may be located:
 - (1) behind nearside front wheel arch (see 3a); or
 - (2) under skirt in vicinity of door (see 3b).

5.59 Pneumatics can be deactivated by:

- a. electrically operating toggle switch on near side under front bumper bar and turning off tap (see 3c);
- b. by pushing black button near door lock (see 3b); or
- c. by hingeing down front number plate & turning tap off (see 3e).

Doors can then be opened manually (see 3d).

BUS/COACH ELECTRICAL SYSTEM

5.60 Vehicle wiring is normally 12 or 24 volts. If the wiring is damaged, ignition of flammable material can occur.

5.61 BATTERY SWITCH

The battery master switch should be found and switched off. It may be located near the dashboard or driver's side console or in the engine compartment close to the batteries.

WARNING: When the master switch is used to isolate the power, all power is not necessarily cut off eg electric powered battery isolating switch (if fitted) or Tachograph (if fitted) are separate. These items of equipment require constant power for their continued operation. Other items of equipment such as C.B. radios, parking lights, saloon lights and other accessories may still operate even after the battery isolating switch has been turned off. The most positive way to isolate all power is to disconnect the battery leads from the batteries. (Rescuers should familiarise themselves with different wiring configurations of batteries.)

5.62 HIGH VOLTAGE WIRES

Long distance coaches fitted with television, often require an inverter to be fitted to the coach for the supply of 240 volts. Contact with wires carrying high voltages, could result in electrocution.

WARNING: 240 volt power may be stored within the system by means of capacitor charged by battery power for a considerable period of time.

BUS/COACH FUEL

5.63 All late model coaches use diesel fuel. Nevertheless, there are a small number of older, petrol-engined buses still in service. Smaller buses use either diesel, petrol or engines converted to liquified petroleum gas (LPG) or compressed natural gas (CNG).

WARNING: Rescue personnel must be aware of the various types of valves and pipe systems to be able to render safe LPG and CNG powered vehicles.

BUS/COACH SUSPENSION

5.64 If a coach or bus is fitted with air suspension, no person should go underneath the vehicle or lean over a tyre inside a wheel arch without having placed substantial support under the chassis and bodywork. If an air bag ruptures or an airline to the suspension is burnt through or damaged, the vehicle may drop without warning, trapping or crushing persons underneath.

5.65 The vehicle can be stabilised by a controlled release of the air suspension, after having established that no persons are under the vehicle.

TRUCKS

5.66 Trucks follow the ladder chassis and separate body type construction. Running gear has many options: single steer, tandem steer, single drive and tandem drive or a combination of any of the above. Cab styles vary considerably as well eg forward control (or cab over engine), 'conventional' or engine in front of cab or a combination of each.

5.67 Access to engine compartments also varies from tip-forward bonnet/guard combinations to tip-forward complete cab. This knowledge may help in gaining access to injured persons in the cab. Note: Sleeper cabs are now common on long distance rigs. These are accessible from the driving compartment and side doors (where fitted) and the rescue team must check the sleeper for occupants.

5.68 Large trucks, when involved in an incident with a smaller passenger vehicle, are rarely damaged above the floor area of the cabin.

SEMI-TRAILERS

5.69 Like buses, semi-trailers pose their own peculiar hazards to rescue personnel. Buses have the problem of mass casualties while semi-trailers provide load problems, along with difficulties associated with identifying the

type of goods being carried. Semi-trailers are made up of a prime-mover (tractor) and one or more trailers (multi-articulated eg B Double etc).

5.70 TRAILER BRAKES

The prime mover may have single, tandem, or triple (tri-axle) driving axles. One of the safety features built into the whole rig is that once the air brake lines are disconnected between the prime mover and the trailer or trailers, the brakes are automatically applied to the trailer, thus preventing movement of a trailer. During a rescue, this may require the rescue team to employ another prime mover or a specially equipped heavy duty tow truck to remove the trailer or trailers. The brakes may be released manually but to tow the trailer an air brake equipped vehicle is required.

WARNING: Some vehicles may be fitted with vacuum brakes. If this is so then the reverse will apply—ie the brakes will release when air is drained.

CAUTION: ALWAYS CHOCK THE WHEELS

5.71 REFRIGERANT/AIR-CONDITIONING GASES/LIQUIDS

During the process of gaining access or disentanglement during a rescue, a refrigeration line may be cut or damaged, so releasing the refrigerant gas/liquid. Rescuers must be aware of potential problems such as frostbite or asphyxiation and appropriate precautions must be observed.

5.72 STOPPING DIESEL ENGINES

Diesel engines power the majority of present day heavy vehicles. In most accident situations, the engine will be stopped before the rescue teams arrival at the scene. However, if the engine needs stopping, the following steps should be attempted:

- a. Turn off the ignition key.
- b. Press the stop button. (This may require the ignition key or switch to be turned on for this button to operate.)
- c. Pull the stop button (generally located near the drivers position).
- d. Operate the shut-off manually on the fuel injector pump.
- e. Discharge CO₂ cylinder into air intake.
- f. Crimp the fuel line on the inlet side of the fuel injector pump (normally rubber tube).
- g. Remove or smash the fuel filters (glass or metal screw type).
- h. Place a flat piece of timber over the air intake.
- i. On some heavy machinery the engine can be stopped by pushing/pulling the throttle control lever past the low idle stop position or

by lifting the accelerator past the low idle stop position. If this fails, the previous methods can be attempted.

WARNING: NEVER pour water down the air intake to stop a diesel engine.

5.73 FIBREGLASS PANELS

Most prime movers have fibreglass roofs and body panels. Entry can usually be made with:

- d. Hacksaw blades—with wide teeth in a 'Pad' holder. The teeth will become clogged and need clearing regularly.
- e. Panel Cutters may be used, but they sometimes tend to tear the fibreglass.
- f. Tin snips may be used (with some difficulty).
- g. Reciprocating saws have proven successful, but like the hacksaw the blade will clog.
- h. Oscillating plaster saw.
- i. Disc cutters/angle grinders, providing the normal precautions are taken when using abrasive discs and power leads.

Note: Air chisels have not proven to be efficient on fibreglass, as the fibreglass does not provide adequate back pressure on the chisel for correct operation.

CAUTION: Rescue Operators cutting fibreglass must cover all exposed skin, wear safety goggles and dust mask to provide protection from fibreglass dust.

SUMMARY

5.74 The object of gaining access is to make openings in the wreckage through which first aiders can reach injured persons and start lifesaving care.

5.75 OPERATIONS SEQUENCE

The following general sequence of operations can be followed when gaining access to a wrecked vehicle.

- a. First attempt to open doors. If they cannot be opened, windows should be removed or broken. If windows cannot be removed or broken, an opening in the body of the vehicle will need to be made.
- b. A backboard can be used to facilitate entry through window openings.
- c. When possible, occupants need to be protected from flying particles of metal or glass. They should be covered and ear protection provided.

- d. Windscreens and rear windows should be removed intact if possible. Bonded windows/windscreens can be removed with a glazier's tool. A sharp knife can be used to remove windows. An automatic centre punch in the bottom corner is used to dispose of tempered glass.
- e. Ducting tape or 'contact' prevents the spread of particles when breaking tempered glass close to an occupant of a wrecked vehicle.
- f. When circumstances dictate, entry may be gained via the roof or floor panels.
- g. The boot, or luggage compartment of a vehicle needs to be checked for occupants or hazardous materials. If the lid cannot be opened with a key, a lever can assist in popping the boot open.

SUPPLEMENTARY RESTRAINTS

1. AIR BAGS

- a. **Air Bag System Components**—An air bag system may consist of crash sensors, one or more air bag modules (depending on whether passenger or side bags are fitted), a back-up power supply, an electronic diagnostic module and a wiring loom. The air bag is designed to inflate following a frontal or near frontal impact, or a side impact for side air bags.

Each air bag module contains an inflator (or gas generator), an igniter and a folded air bag, along with the hardware required to package it behind a special plastic trim cover. The trim cover incorporates tear seams which separate during deployment, allowing the bag to inflate.

The electrically-operated system includes a diagnostic module to self-test the system and identify any faults. A back-up power supply is also included in the system, should the battery of the vehicle become disconnected in the initial phase of the impact.

- b. **Operation of Air Bag Systems**—When the crash sensors detect a deceleration of sufficient magnitude, a signal is sent (either electrically or mechanically) to the igniter. This causes solid chemical propellant sealed inside the inflator to undergo a rapid chemical reaction.

Following deployment of an air bag, some smoke will be present in the vicinity. This will be a mixture of small traces of baking soda combined with corn starch or talc which is used to lubricate the bag during deployment. There are no accessible parts of the system which will be hot. The air bag module is also designed to trigger if it reaches a temperature of 150° Celsius (eg a vehicle fire).

- c. Rescuers Guidelines For Air Bag Systems :

(1) *Fire in Air Bag-Equipped Car:*

Use standard fire-extinguishing procedures.

Note: Undeployed air bags may deploy.

(2) *Air Bag Deployed:*

- (a) Use normal rescue procedures and equipment.
- (b) Wear prescribed protective clothing/equipment (gloves and eye protection must be worn).
- (c) Avoid getting air bag powder/dust into eyes or wounds (this applies to rescuers and vehicle occupants).
- (d) Push deflated air bag aside for access.

- (e) Be aware of hot parts under the air bag fabric (inside steering wheel hub). The air bag fabric, steering wheel column and rim will not be hot.
 - (f) Wash hands after handling deployed air bag.
- (3) *Air Bag Not Deployed:*
- (a) An air bag is unlikely to deploy after a crash.
 - (b) Never cut or drill directly into an air bag module.
 - (c) Do not touch exposed chemicals if the inflator cannister is opened.
 - (d) Deactivate the air bag and commence normal rescue procedures (disconnect the battery).
 - (e) While the air bag is being deactivated, or if it is unable to be deactivated the following should begin immediately:
 - (i) **DO** move a stabilised occupant as far rearward from the air bag as possible.
 - (ii) **DO** turn off the ignition.
 - (iii) **DO** disconnect the battery (be aware this may not deactivate the system).
 - (iv) **DO** perform rescue efforts from the side of the vehicle away from the bag deployment path.
 - (v) **DO** keep your body and objects/tools off the trim cover and away from the bag deployment path.
 - (f) **DO NOT** apply sharp blows to the steering column or dash board.
 - (g) **DO NOT** cut into the steering column or apply heat near the air bag module (it is OK to cut the steering wheel rim or spokes).

NOTE A. IF IN DOUBT, ASSUME AN AIR BAG IS FITTED TO THE VEHICLE.

NOTE B. BACK-UP CAPACITORS IN AIR BAG SYSTEMS MAY STILL BE CAPABLE OF TRIGGERING AN AIR BAG AFTER POWER IS DISCONNECTED (UP TO 30 MIN). REFER TO MANUFACTURES SPECIFICATIONS.

NOTE C. MECHANICALLY-TRIGGERED SYSTEMS MAY BE DEACTIVATED IN THE FIELD, HOWEVER, THIS ACTION IS NOT RECOMMENDED DURING RESCUE OPERATIONS.

Further information can be obtained from the latest editions/information of the following:

- Emergency Rescuers Guide to Cars Fitted With Air Bag Supplemental Restraint System (Air Bag SRS).
- Vehicle Manufacturers.
- Automobile Clubs or Associations.

2. SEAT BELT PRE-TENSIONERS

- a. **Seat Belt Pre-tensioner Components and Operation**—Seat belt pre-tensioners are devices which operate in support of Air Bag Systems to further restrain the occupants during rapid deceleration.

These devices can be fitted directly to either or both of the lower anchor points (ie reel or buckle). The device is triggered by similar (generally shared) sensors to the Air Bag systems, and only triggers on frontal or near frontal impacts. Like Air Bag units these devices can also be either mechanically or electrically-triggered. In the case of inertia reel-mounted pre-tensioners, a set of jaw clamps cause the belt to be wound in. When the retraction of the seat belt is complete, the tension causes the anti-reverse gears to mesh with each other in the position of the belt is maintained. This process takes approximately 21 milliseconds to complete. In the case of buckle mounted pre-tensioners, the system is similar, but in this case the buckle is physically retracted as the piston moves, pulling the belt with it.

- b. **Identification**—As with air bag systems, no standard or required markings currently exist to identify vehicles with pre-tensioners fitted. Given that seat belt pre-tensioners are generally found in the presence of an air bag, the rescuer should first establish this fact. Following this, the only tell-tale signs that a tensioner is likely to be installed, will be either an enlarged inertia reel housing, at the base of the tile 'B' pillar, or possibly an enlarged seat belt buckle anchor housing. As with air bags, in the first instance, assume the device exists until proven otherwise.

- c. **Rescue Considerations:**

- (1) Release the belt by cutting at least 30 - 45 cm from any anchor point. This will allow the belt to retract, if the device has not deployed.
- (2) Considerable care should be taken when cutting or ramming at the base of the 'B' pillar, to ensure that the device, if present, is avoided. Extrication should, however, not be compromised.
- (3) Some vehicles are fitted with a height-adjustable shoulder anchor point. From an extrication point of view, this device presents no danger to the rescuer, however, allowance will have to be made, when cutting the top of the 'B' pillar, for an increased diameter and extra metal.

There is a strong possibility that these devices will trigger in a fire situation, given their pyrotechnic nature.

CHAPTER SIX

EMERGENCY CARE

INTRODUCTION

6.01 Ideally all road accident rescue personnel should be trained in basic medical emergency procedures. As occasions will arise where rescue personnel will have to take first aid initiatives in the absence of ambulance or qualified medical personnel, this chapter is a guide to basic first aid principles.

FIRST AID

6.02 PRIORITIES

First aid priorities are:

1. dangers;
2. airway maintenance;
3. breathing restoration;
4. circulation restoration;
5. haemorrhage control;
6. crush injury management;
7. fracture immobilisation; and
8. communicable diseases.

6.03 Problems with airway, breathing and circulation are all separate problems dealt with individually. However, they must also be considered collectively as part of a total package. Any casualty may need management of only one or possibly all three of these areas.

6.04 BREATHING

If the casualty has a blockage of the airway, this must be cleared. If breathing has stopped, the rescuer must breathe for the casualty after first clearing the airway (ie Expired Air Resuscitation/EAR).

6.05 HEARTBEAT

If the casualty's heart has stopped beating, artificial circulation must be provided (External Cardiac Compression/ECC). The techniques of resuscitation are described in Annex A.

6.06 BLEEDING

Since body functions depend on an adequate and uninterrupted supply of blood, any opening in the circulatory system through which blood may be lost should be considered dangerous.

6.07 Severe or continued bleeding may lead to collapse and death.

6.08 The rescuer must be able to recognise, and if possible, control and manage a haemorrhage (see Annex B).

WARNING: See Annex C—Communicable Diseases.

6.09 COMPRESSION AND SPINAL INJURY

It is important that rescue personnel be able to recognise:

- a. a trapped casualty suffering a compression (crush) injury and to have an understanding of the techniques in releasing the compressive force and the management of the possible resulting syndrome (if this situation is not understood and correctly managed, it can lead to death of the casualty (see Annex D)); and
- b. an injury situation involving suspected spinal damage and implement appropriate handling techniques (see Annex E).

FIRST AID PRIORITIES

In a medical emergency it is necessary to have an action plan, one that will work every time, regardless of the type of incident. The following action plan is called DRABC each letter stands for something the rescuer must do, and the sequence in which it will be done.

The following chart sets out the DRABC action plan, comprising:

D—Danger R—Response A—Airway B—Breathing C—circulation the chart also shows the order of priority and the appropriate time for the control of bleeding and the care of the unconscious casualty.

All first aid management begins with DRABC

EMERGENCY CARE ACTION PLAN

<p>Check for danger to:</p> <p style="padding-left: 40px;">yourself; the casualty; and bystanders.</p> <p>Act only if safe to do so:</p> <p style="padding-left: 40px;">Do not become the next casualty. Remove danger from the casualty, or if necessary the casualty from danger. Warn bystanders of any danger and ask them to keep a safe distance.</p> <p>If unsafe, wait for expert assistance to arrive.</p>	<p>D—Danger</p>
<p>Check for response:</p> <p style="padding-left: 40px;">Gently shake and shout loudly. If the casualty responds, check and control serious external bleeding. If no response, proceed with ABC.</p>	<p>R—Response</p>
<p>Firstly place casualty on side, then:</p>	<p>A—Airway</p>

<p>open the mouth; clear if needed; and keep the airway open (head tilt and jaw support).</p>	
<p>Look, listen and feel:</p> <p>Is the lower chest or the abdomen rising and falling? Can you hear breathing sounds? Can you feel breathing?</p>	<p>B—Breathing</p>
<p>Then:</p> <p>if the casualty is breathing but not responding place onto side; or if the casualty is not breathing, start expired air resuscitation (EAR).</p>	
<p>Check the carotid neck pulse:</p> <p>If present, continue EAR. If absent, start cardiopulmonary resuscitation (CPR).</p> <p>Note: These procedures apply to a casualty outside of a vehicle. Considerable improvisations may have to be implemented for the casualty trapped inside a vehicle.</p>	<p>C—Circulation</p>

HAEMORRHAGE CONTROL

1. INTRODUCTION

Bleeding may be external, internal or both. When bleeding occurs internally, treat for shock and elevate the lower extremities if possible. This casualty must be transferred to a medical facility as quickly as possible, since surgical procedures may be required to stop the bleeding.

2. TYPES OF EXTERNAL BLEEDING

Bleeding is classified according to its source:

- Arterial
- Venous bleeding
- Capillary bleeding

Arterial bleeding is characterized by the flow of bright red blood that issues from the wound in distinctive spurts.

Venous bleeding is characterized by a steady flow of blood that appears to be dark red. Although it may be profuse, it is much easier to control than arterial bleeding.

Capillary bleeding is characterized by the slow oozing of blood, usually from minor wounds such as abrasions. It is easily controlled. Normally the threat of contamination may be more dangerous than blood loss.

3. CONTROL AND MANAGEMENT

There are very few situations in which external bleeding cannot be controlled. Since this is one of the most common conditions that rescuers will encounter, they should be thoroughly familiar with the techniques of control.

Severe external bleeding from sometimes gruesome wounds taxes the presence of mind and self-control. The ability to think clearly, act calmly and keep a tight rein on emotions is most important. The methods of controlling external bleeding will be discussed in the order of priority.

4. DIRECT PRESSURE

The most effective method of controlling external bleeding is by pressure applied directly over the wound and then elevation of the site if possible. This should then be followed by the application of a suitable dressing pad and bandage.

5. PRESSURE POINTS

If bleeding cannot be controlled using direct pressure in conjunction with elevation, especially when an extremity is involved, pressure on a strategic pressure point may be required.

A pressure point is a site where the main artery to the injury lies near the surface of the skin and directly over a bone.

6. CONstrictive BANDAGE

If direct pressure and the use of pressure points do not effectively control external bleeding, a constrictive bandage should be used, but only as a last resort. Such situations are rare and usually involve traumatic amputations. If a constrictive bandage is applied to a limb, **it must only be removed by a medical officer**.

7. REMEMBER

A constrictive bandage must be at least 3 cms in width and should be used only to control life threatening bleeding that cannot be controlled by other means.

Even then it should be used only with the complete understanding that it may mean the loss of the limb to which it is applied.

8. NOTE

External bleeding from the ear canal **must not be stopped** under any circumstances.

Given this situation the blood and or clear fluid should be allowed to drain freely from the ear.

COMMUNICABLE DISEASES

1. INTRODUCTION

Communicable diseases (also called contagious or infectious diseases) are those diseases which may be transmitted from one individual to another.

There are several ways diseases can be transmitted:

- DIRECT—From the infected person.
- INDIRECT—From dressings, linens or surfaces.
- AIRBORNE—From the infected person, coughing or sneezing.
- VEHICLE—Via ingestion or contaminated food, drugs or blood.
- VECTOR—Via animals, eg ticks.

Communicable Diseases have always existed, but only a small number should concern the rescuer.

This Annex will cover the two Communicable Diseases (AIDS and Hepatitis) where the rescuer is considered to be most at risk in managing a casualty involved in a road accident rescue.

2. HEPATITIS

Hepatitis is an inflammatory disease of the liver, the major causes of which are Type A, B and C Viruses.

The following sections describe the three types of Hepatitis:

a. TYPE A HEPATITIS

Type A Hepatitis is caused by a virus. It is spread primarily via the Fecal-Oral Route.

Blood and other body secretions are infectious. Type A Hepatitis is generally mild in severity and has an excellent prognosis.

b. TYPE B HEPATITIS

Type B Hepatitis is caused by a virus. It is usually transmitted by injection, or sexual contact.

The injected route may involve transmission of contaminated blood or blood products.

The Type B virus is present in blood, saliva, semen and urine of infected persons.

Sexual partners of Type B Hepatitis patients are at risk of infection.

Among the at-risk population are intravenous drug abusers, homosexual or bisexual males and medical personnel. Rescuers may become infected from the blood or

saliva of an infected casualty, from contact with body fluids that enter the rescuer's body or from contaminated or soiled clothing.

Type B Hepatitis is a serious illness and is often life-threatening.

c. TYPE C HEPATITIS

Type C Hepatitis is caused by at least two different viruses that are unlike those involved with either Types A or B.

Transmission of this type of Hepatitis is usually related to a blood transfusion or contaminated needle puncture.

d. SIGNS AND SYMPTOMS OF HEPATITIS

Hepatitis may vary from a minor flu-like illness to fatal liver failure. The usual signs and symptoms are:

- loss of appetite;
- weakness, exhaustion;
- nausea;
- vomiting;
- fever;
- skin rash;
- dark urine; and
- jaundice.

e. PRECAUTIONS

Precautions with managing casualties with Hepatitis, especially those with Type B are similar to those identified for suspected or identified AIDS patients.

If a rescuer is exposed to Type B Hepatitis or work in a high-risk environment, vaccination should be considered. Vaccination will provide active immunity against Type B Hepatitis infection.

3. ACQUIRED IMMUNE DEFICIENCY SYNDROME (AIDS)

a. DEFINITION

AIDS is caused by a virus that attacks the immune system of the body and damages a persons ability to fight other diseases and ultimately causes death.

There is presently no cure for AIDS.

b. RISK GROUPS

Ninety-eight per cent of reported cases of AIDS in Australia fall into the following categories:

- Homosexual or bisexual men
- Intravenous drug users
- Recipients of blood or blood products
- Sex partners or persons in these groups
- Children born to infected mothers

c. HOW IS AIDS TRANSMITTED?

AIDS is transmitted mainly by blood, body fluids or sexual contact.

Rescue personnel are often involved in critical trauma situations that may expose them to casualties who may be in the above mentioned high risk groups.

These situations may involve direct person to person contact when CPR is being performed, or by coming into contact with an infected person's blood or body fluids during rescue attempts.

Although the AIDS virus is found in several body fluids, eg saliva and tears, there have been no reported cases of emergency service personnel contracting the virus by the application of mouth to mouth resuscitation.

d. PRECAUTIONS

It is important that the rescuer takes precautions to prevent or reduce the transmission of AIDS.

The following is recommended for all road rescue personnel who manage the extrication of casualties from motor vehicles:

- Wear latex rubber gloves if hand contact with body fluids is likely to occur.
- In addition to gloves, if the casualties environment involves high risk or a high blood profile, additional protective measures may be necessary. The use of eye goggles, and face masks may be prudent protective measures.
- If the casualty requires respiratory resuscitation, use a face mask and avoid mouth to mouth contact if possible.
- The rescuer should wash hands and any affected skin areas thoroughly with soap and running water.
- If the rescuer has been exposed to the blood or other body fluids of a suspected AIDS infected casualty, for example, blood that has entered a cut on the finger or the splashing of another body fluid into the mouth or eyes, a doctor should be contacted without delay.

e. SUMMARY

Rescue personnel when managing the extrication and treatment of road accident casualties will in general not be aware if those persons are infected with the Hepatitis or AIDS virus.

Therefore all precautions should be taken to minimise the risk of contamination and infection.

Hepatitis is a much easier virus to contract and is more prevalent than AIDS.

The AIDS virus is a very fragile virus and is more difficult to contract.

f. NOTE:

When extricating a deceased person who is a known or suspected AIDS carrier, it is possible to contract the virus while the deceased still has a recordable body temperature.

COMPRESSION (CRUSH) INJURY

1. GENERAL

Crush injury results from the application of a crushing force to any part of the body. A major crush injury may lead to the development of 'crush syndrome' following release of the crushing force.

2. CRUSH SYNDROME

Crush syndrome is a complication which may occur following the release of a compressive force which has compressed a major muscle mass for a period exceeding thirty (30) minutes. The crush syndrome may lead to sudden death, shock or other heart and lung emergencies. The syndrome occurs as a result of harmful chemicals being released from the damaged muscles and the reabsorption of these chemicals back into the blood stream following removal of the crushing force.

3. RECOGNITION

The syndrome may present as the sudden development of any of the following:

- giddiness;
- thirst;
- nausea;
- cold clammy pale skin;
- erratic heart beat;
- rapid shallow respirations;
- confusion, disorientation; or
- unconsciousness.

4. APPROACH TO REMOVING THE COMPRESSIVE FORCE

The following approach may help identify those situations where the patient will be most at risk of developing crush syndrome.

SPINAL INJURY

1. INTRODUCTION

In vehicle accidents, spinal injuries are often overshadowed by more obvious and gruesome injuries like fractures, lacerations to the face and body and chest injuries. Poorly trained rescue personnel often have trouble in identifying spinal injuries and if they do find a spinal injury, it is usually after the more obvious wounds have been treated and the casualty has been moved. By this time any spinal injury caused during the accident will have been made worse, and the casualty may now have permanent and irreparable damage.

For this reason it is vital that the rescuer be able to recognise a spinal injury and be able to immobilise the spine quickly and correctly, since correct immobilisation may mean the difference between complete recovery, a life long paralysis, or even death.

2. RECOGNITION

For any person who has been involved in a motor vehicle accident, the rescuer should assume a spinal injury if that person:

- a. is unconscious or has a significant head injury;
- b. complains of pain in the neck;
- c. complains of numbness, tingling, or 'pins and needles', in any limb or limbs;
- d. complains of inability to move, or decreased strength in any limb or limbs;
- e. complains of electric shock sensation on movement;
- f. has obvious deformity of the spine; or g. is paralysed

3. MANAGEMENT

The most important thing to remember is the 'ABC' (ie Airway, Breathing, Circulation) of first aid, resuscitation being the primary function. If an injury to the neck or back is suspected, the spinal column must be immobilised. It is most important not to move the spine prior to immobilisation. If it is moved, spinal cord damage may occur due to pieces of bone compressing the spinal cord.

4. NOTE

All casualties with neck pain, injury or deformity should be managed as follows.

- The head and neck supported by hand until other support can be arranged; this is most important if the casualty is found in a sitting position, as when trapped in a motor vehicle.

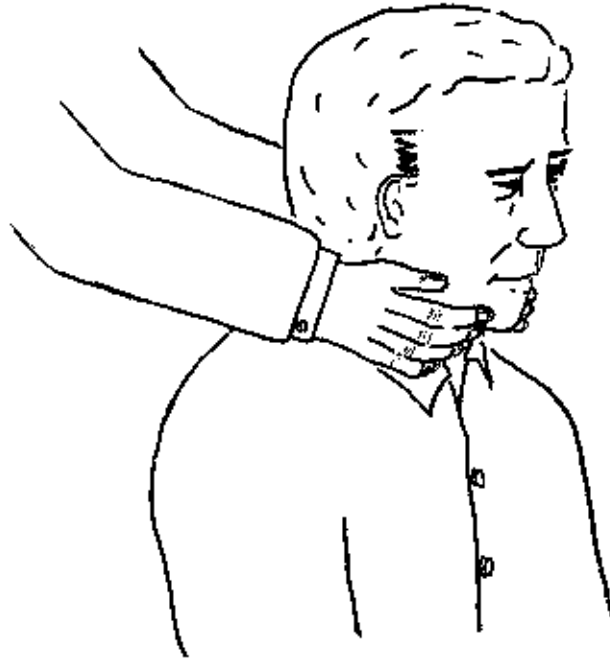

- Figure 6E:1 Head and Neck Support
- The application of a cervical collar if available, or a rolled up towel placed gently around the neck (like a scarf) for support.
- The securing of a short or long back board for support prior to being moved.

5. SUMMARY

- ABC
- Immobilise.
- Lift casualty in position found.
- Don't move casualty unnecessarily.

6. WARNING

If you don't think about a spinal cord injury

YOU WILL MISS IT!!

CHAPTER SEVEN

DISENTANGLEMENT

INTRODUCTION

7.01 Disentanglement is the removal of wreckage from around a casualty, not the removal of a casualty from the wreckage.

7.02 DISENTANGLEMENT ACTIVITIES

There are five disentanglement activities which will result in the eventual extrication of the casualty. They are as follows:

- a. **Adjustment**—The movement of vehicle components through in-built adjustment mechanisms.
- b. **Disassembly**—The separation of components by reversing the order in which they are assembled.
- c. **Distortion**—The forcible twisting of a vehicle's parts to get them out of the way.
- d. **Displacement**—The movement of a component from one place to another or the removal of a component.
- e. **Severance**—The cutting of components so that they can be removed.

7.03 CONSIDERATIONS

Prior to selecting a disentanglement activity, four points should be considered:

- a. Define what is to be moved.
- b. In which direction should it go?
- c. How much force is required to move it?
- d. What distance does it need to be moved?

Note: In all of the disentanglement techniques described in this chapter, a crew member should where possible, be positioned as a safety observer. This safety observer's task is to closely monitor the specific operation to detect at an early stage, any potential danger to the rescue operator or the casualty.

RELEASE

7.04 Freeing and removing the casualty should be completed in consultation with the casualty care officer.

7.05 USE OF HANDS

The first pieces of equipment which are most readily available to rescuers are their hands. They are the safest, most sensitive and most efficient in many instances. Disentanglement should not be commenced until all hidden areas which can be reached have been thoroughly explored by hand.

CAUTION: When using hands (even in gloves) around unseen areas of a vehicle, particularly when checking under seats or in glove boxes etc, be aware that syringes may have been hidden, and syringes can be the cause of HIV/Hepatitis B and C infection.

7.06 Many rescues are accomplished by using the hands or simple tools rather than specialised equipment. Specialised equipment may be used at any time but may also prove to be unnecessary in the first instance if correct assessment has been carried out.

Note: Do not forget to check for the ability to adjust seats/steering columns etc.

7.07 The action to be taken will depend upon the experience, training and common sense of the rescue personnel.

7.08 HIDDEN PROTRUSIONS

These could be penetrating the casualty's body, legs or feet. If further pressure is placed on the vehicle, considerable internal injury could occur to the casualty by either forcing the protrusion further into, or dragging it across the body. In the case of penetration to the trunk, this may open or extend the wound, with every possibility of fatal consequences.

7.09 MINOR OBSTRUCTIONS

A person may be trapped by minor obstructions. Some examples and actions follow:

- a. An apparently free body cannot be moved ûnclip or cut the seat belts. (Individual state/territory policy or operational necessity will dictate.)
- b. The chest wedged against steering wheel or knees under dash:
 - (1) After making sure all debris is removed from around and behind the seat, depress the seat slide and at the same time firmly push the seat back.
 - (2) Should the seat adjustment be inoperable and the steering column not able to be adjusted, the back of the seat may be bent down by one or two rescuers, with their shoulders firmly placed against the roof of the vehicle and their hands on the back of the seat pushing down firmly. This should be carried out as smoothly as possible, avoiding sudden jerks to limit the possibility of further spinal injuries, particularly in the cervical area. Normal first aid procedures should be followed prior to any movement.

- (3) As a last resort, it is possible to cut the seat to remove foam rubber and other materials from under the casualty. The lowering of the casualty in this manner may sometimes permit extrication.

c. Casualty's feet trapped:

- (1) Slide the trapped foot from the shoe (untie laces).
- (2) Cut the shoe away from the foot.
- (3) Displace pedal by attempting to move sideways by hand, by hydraulic spreader, or by tying a rope around the pedal and using a door to gain leverage (see Figure 7:1).
- (4) Sever pedal.

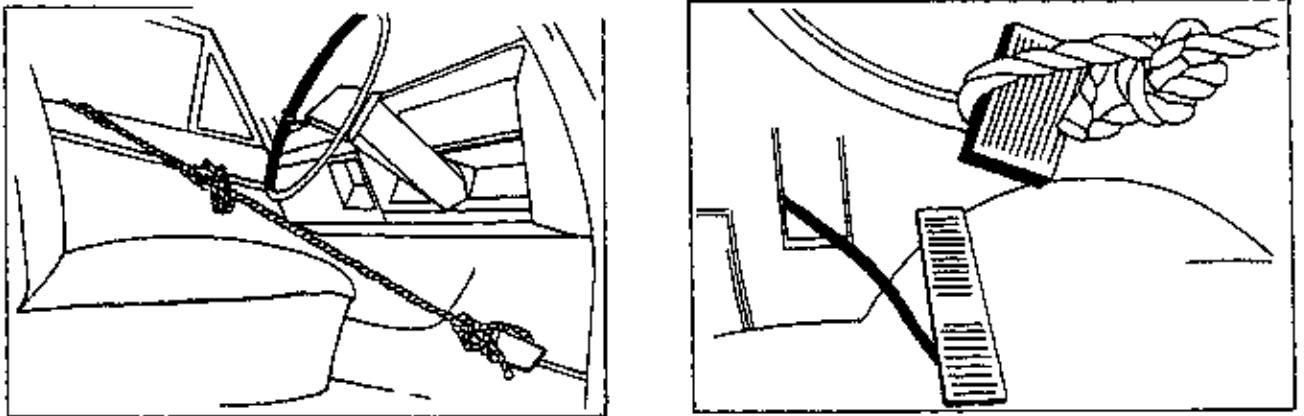

Figure 7:1
Displacing Pedal

7.10 CLEARING A PATH

Disentanglement also involves making a pathway through wreckage which facilitates the safe and easy extrication of the casualties. During this process, patients are protected from harm by the use of blankets, ear muffs, padding and eye protection as appropriate, as the rescuers remove wreckage and obstructions. Where possible, communications should be maintained with casualties to allay their fears and keep them informed.

7.11 CASUALTY PROTECTION

This is vital. To minimise patients' concerns, rescuers should ensure that there is adequate ventilation when there is a need to completely cover them. Where possible, a rescuer should be placed under the covering with the casualty. Protection such as half backboards or padding should be used to prevent the casualty coming into contact with obstructions or tools.

WIDENING OPENINGS

- 7.12 Vehicle doors are designed not to open a full 90 degrees and varying sized openings occur when doors are damaged. A much wider opening may be required to remove a casualty. This can be accomplished by displacement or removal of the doors.

7.13 There are various methods of widening the door opening:

- a. Two or three rescuers can take hold of the door at its outer extremity. With a firm push, the door can be forced past its usual travel. Care should be taken not to rock the vehicle.
- b. The use of hand tools, such as spanners, sockets, hacksaws, crowbars and hand winches, or hydraulic equipment to remove the door.

SEATS

7.14 A hand winch and chain may be used to pull the seat back. One method is to use the technique shown in Figure 7:2.

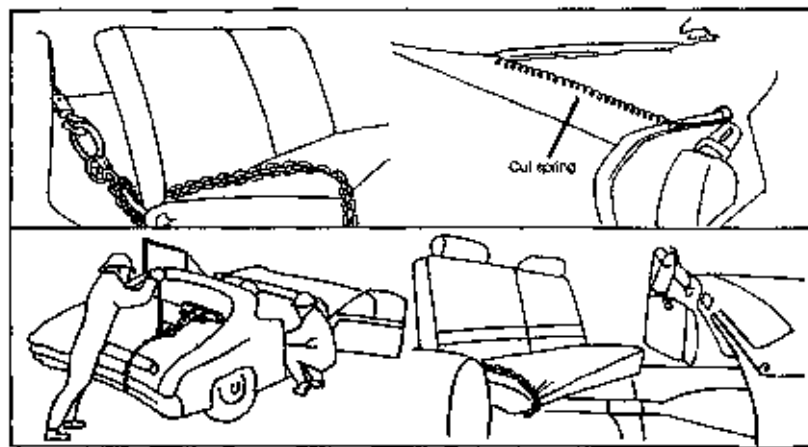

Figure 7:2
Displacing Seat (Pull)

The boot lid is removed or raised, the winch positioned in the boot and a cut made through the squab of the rear seat. The winch cable is passed through this opening. Alternatively, either the squab can be removed or the seat removed by unbolting the seat supports using a socket and ratchet handle. Rescuers should ensure that the winch is positioned as low as possible in the boot.

CAUTION: Because of the danger to an entrapped person, only as a last resort should the chain be passed over the rear seat and through the rear window. If this procedure proves necessary, the roof should be removed first (as shown in the diagram).

7.15 Another technique is to use hydraulic equipment or a mechanical jack of high capacity (10t) to push the seat back off its rails/track.

CAUTION: Extreme care should be exercised when pushing or pulling seats with casualties in position. The release of the seat from the runner may cause further injury to the casualty.

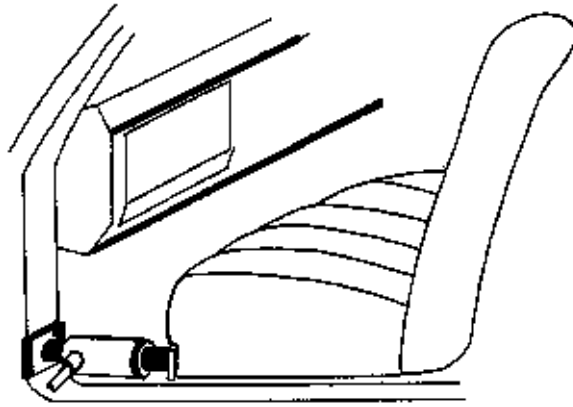

Figure 7:3
Displacing Seat (Push)

7.16 STEERING WHEEL/COLUMN

The steering column can be displaced by using existing design adjustments or by undoing bolts on the column bracket. Alternatively, hydraulic rams, power hydraulic spreaders/rams and chains or hand winches can be used.

CAUTION: 1 Air lift bags should not be used for this task due to possible sudden release of stored energy.

CAUTION: 2 Care needs to be taken not to overstress the pull. The columns must only be moved as far as necessary. Moving the column too far can cause equipment/ column failure eg a column can enter the passenger compartment due to the failure of universal joints at floor level.

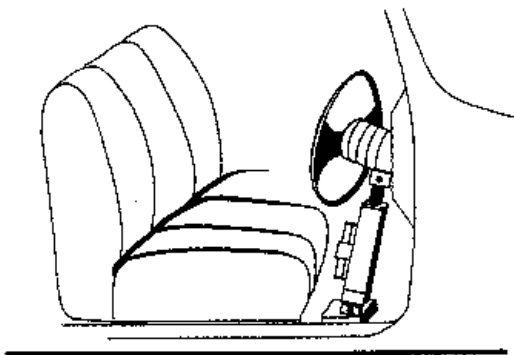

Figure 7:4
Displacing Steering Column (Push)

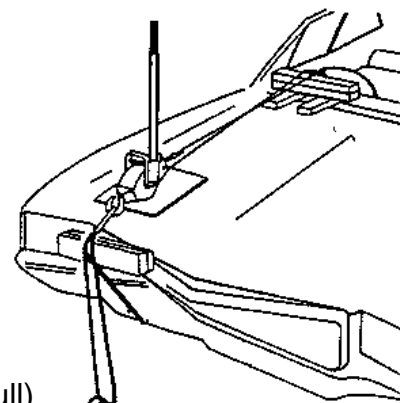
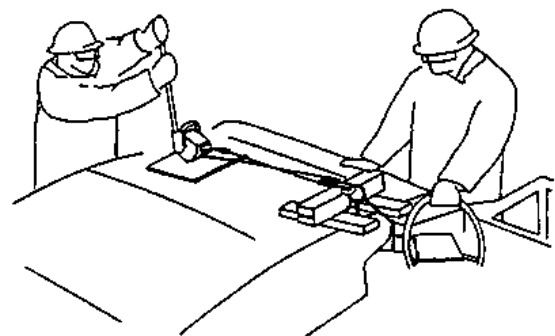

Figure 7:5
Displacing Steering Column (Pull)

7.17 STEERING WHEELS

Most steering wheels, regardless of their cosmetics, are simply a circle of 8 mm round steel and may be cut by large bolt cutters or hacksaw.

CAUTION: Some steering wheel rings are formed under tension and when cut, may spring out with considerable force.

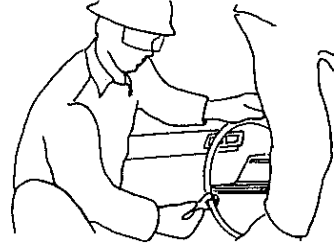
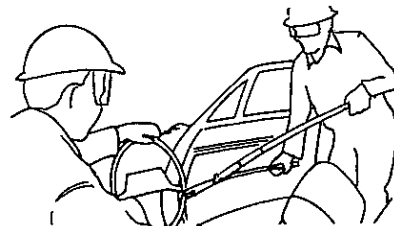

Figure 7:6
Severing Steering Wheel



7.18 STEERING COLUMNS

Severing the column may be accomplished by the use of a hacksaw or by reciprocating saw. Hydraulic shears may be used, but this technique can be hazardous to personnel and damage equipment.

7.19 AIR BAGS AND SUPPLEMENTARY RESTRAINTS

Rescuers must make themselves aware of air bag restraint systems and the methods by which they can be de-energised. Accidental activation of these systems may cause injury to the casualty or rescuer. Refer to Annex A to Chapter Five for further details.

PANEL METAL ENTRAPMENT

7.20 Sometimes persons involved in vehicle accidents become trapped by panel metal. This 'wrapping' presents the rescuers with a special problem in disentanglement. There usually is no quick way of removing the panel metal. Spreaders used carefully can progressively open the entrapment. A reciprocating saw may be used when space permits but extreme caution should be exercised to avoid further injury to the casualty.

HEAD THROUGH WINDSCREEN

7.21 This situation may occur when an unrestrained occupant of the vehicle is thrown forward into the windscreen. If the head is pulled back, shards of glass may be driven into the head or neck.

7.22 SHARD REMOVAL

When satisfied that the casualty is properly stabilised, the rescuer should look for long shards that are hinged to the windshield pressing against the skin.

These are bent away from the casualty and the point of a sharp knife is run in the fracture line to cut the plastic sheeting that holds the layers of glass together. This will allow the removal of the shards.

7.23 COLLAR FITTING

When all the shards have been removed from direct contact with the casualty's neck, a collar can be fashioned from a trauma dressing. The collar is then placed between the victim's chin and the glass surface, and worked until it is between the neck and the glass.

7.24 Before the casualty's head can be guided back through the windshield, it is necessary to enlarge the opening in the glass. Broken glass segments should be removed continually.

7.25 ALTERNATIVE METHOD

An alternative method of freeing the casualty involves removing the top of the windscreen. After first aid and stabilisation have been completed, the roof is cut just forward of the B pillars, followed by cutting the A pillars at the windscreen edges parallel to the hole. The glass is then chipped gently with a ballpeen hammer working in a straight line from the hole to the outer cuts. The sheeting plastic can then be cut with a sharp knife and the top of the windscreen lifted clear, by creasing the roof and folding backwards and clear.

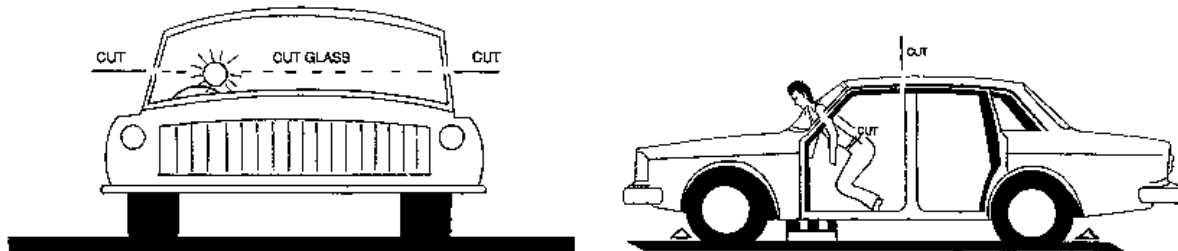

Figure 7:7
Extrication of Casualty with Head Through Windscreen

7.26 IMPALEMENT

Vehicle collisions may result in the casualty being impaled by pipes, reinforcing rods, tree limbs, guard rails or parts of the vehicle. Impalements may be to any part of the casualties body and must not be removed by the rescuer. If possible, the object should be cut about 100 ÷ 300 mm from the casualty's body.

CAUTIONS: Rescuers need to be aware of:

1. the compression or tension forces which may be released when the object is cut; and
2. the casualties must be protected from heat transfer during cutting and vibrations.

DASH HINGE TECHNIQUE

7.27 The dash hinge technique relies on correct placement of cuts, particularly at the firewall and junctions. This ensures that the hinging occurs through the light metal panel at the front of the vehicle. During this operation, it is important that a safety observer monitor the movement of the floor pan and pedals for the protection of the operator and casualty.

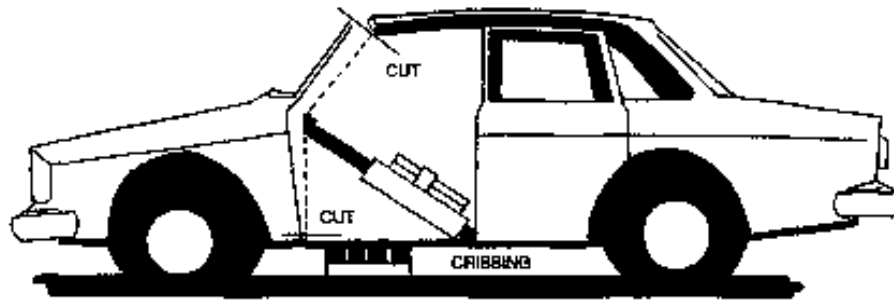

Figure 7:8
Dash Hinge (Sedan)

Note: A push or pull operation may be employed (ram or winch).

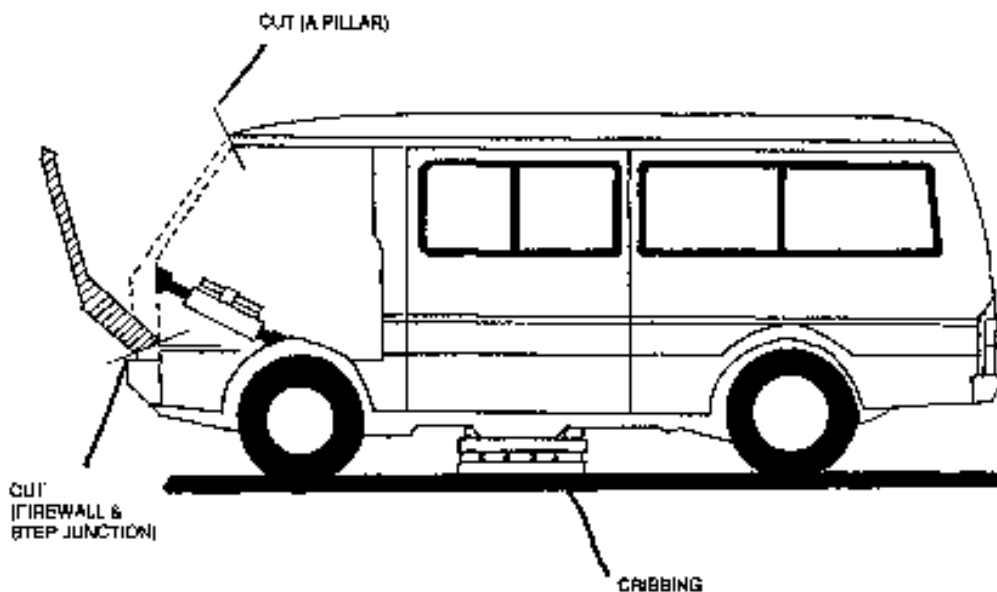

Figure 7:9
Dash Hinge (Van)

CHAPTER EIGHT

REMOVAL AND TRANSFER

INTRODUCTION

8.01 Patient removal and transfer involves two distinct operations. These are defined as follows:

- a. **Removal**—The movement of a casualty from the wreckage to a location outside the vehicle.
- b. **Transfer**—The movement of a casualty from that location to an ambulance or other transportation mode.

REMOVAL

8.02 There will be occasions when removal may be a simple operation, whereas the transfer may be over difficult terrain and involve the use of special techniques and equipment.

8.03 PERSONNEL LIAISON

To prevent further injury during removal, the patient must be fully supported and protected. Close liaison is essential between the rescuers and the person responsible for casualty care.

8.04 TECHNIQUES

Various techniques for casualty removal may need to be employed and include the use of short or long backboards, cervical collars, rope slings, etc. These techniques must always be employed in conjunction with correct casualty preparation and should be conducted under the direction of the casualty care officer.

8.05 POST-REMOVAL

After the removal phase has been completed, all action from this point will be to assist in the transfer of the casualty to the ambulance/transportation mode

TRANSFER

8.06 The transfer may simply be moving the casualty a short distance over level ground or it may involve a long distance over difficult terrain. Some casualties may be seriously injured or unconscious, therefore speed of transfer may be paramount, but must be consistent with safety and correct handling to prevent further injury.

8.07 TECHNIQUES

That used will depend on the condition of the casualty, injuries sustained and the availability of equipment. Frequent inter-service training and exercises should be conducted in removal and transfer techniques, using live persons

as casualties to give rescuers and those responsible for casualty care understanding and confidence in the various methods.

8.08 MOVING THE CASUALTY

To move the casualty, a spine board, or other device should be used so that the patient can be immobilised and moved as one. The body of the patient should not be flexed, extended or rotated. If possible, injured parts should be immobilised in the position in which they are found. The degree of recovery of a patient will depend on the extent of the initial trauma, the prevention of further trauma during rescue operations, and the transporting of the patient to hospital.

8.09 LIFTING

If the rescuer must move the patient or assist the casualty care officer, the casualty can be moved with relative safety if lifted by three or more persons. Rescuers must make every effort to prevent all active and passive movements of the spine of the casualty. The casualty's head must be held securely. The shoulders are supported by a rescuer's hands. During the lift, the trunk and limbs must be aligned and supported by other rescuers. The casualty can then be moved slowly and carefully.

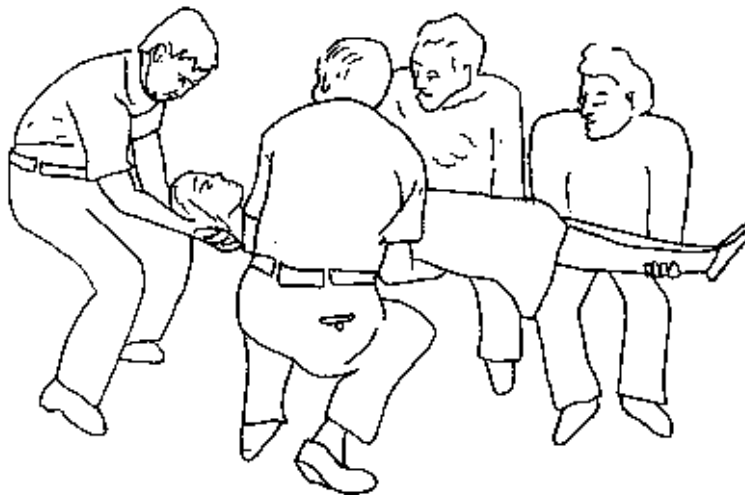

Figure 8:1
Moving the Casualty

PLANNING

8.10 Rescue and casualty care personnel must carefully plan the transfer and ensure that the casualty is constantly monitored.

8.11 TECHNIQUES AND IMPROVISATION

There are many techniques of transferring casualties under adverse circumstances. It is not enough for rescuers to have a variety of equipment and appliances at hand. They should have a wealth of ingenuity to assist in improvisation.

Note: Approval should be sought from the police prior to moving or removing deceased persons from the wreckage unless essential to preserve life.

CHAPTER NINE

TERMINATION

INTRODUCTION

- 9.01** The termination phase of any road accident rescue must include the following considerations:
- a. Final Check.
 - b. Removal of Debris.
 - c. Termination of Operations.
 - d. Clean-Up and Preparation.
 - e. Reports.
 - f. Operational Debrief.
 - g. Critical Incident Stress Debriefing (CISD).

FINAL CHECK

- 9.02** A final check on the vehicle must always be carried out. There is always a possibility that a baby or small child could be left in some obscure part of the vehicle.

9.03 VEHICLE AND SURROUNDINGS

Checks must be made in the area between the seats, and amongst debris which might indicate that children were in the vehicle. Surrounding scrub, ditches and drains need to be thoroughly searched for casualties who may have been flung from the vehicle on impact. Under the dash, under the car, the sleeper cabs of trucks, particularly if overturned, need to be examined prior to leaving the scene.

REMOVAL OF DEBRIS

- 9.04** Preservation of evidence and scene-integrity are vital, to ensure police can conduct an accurate investigation. Therefore, debris is not to be moved until cleared by the police OIC. The smallest piece of wreckage and its location may be vital in any subsequent investigation.

9.05 RESPONSIBILITY

The responsibility for removal of broken glass, debris etc, from roadways, varies throughout Australia. However, where this is a major task, rescuers may assist with debris removal, but only after all unit operations and requirements are complete.

TERMINATION OF OPERATIONS

- 9.06** The rescue leader must check with the other authorities involved prior to leaving the scene as they may still require the assistance of the rescue unit even though the casualty may have been released.
- 9.07** Rescuers need to be aware that it may be necessary to stand by for some time while police carry out functions such as Disaster Victim Identification (DVI) or Accident Scene Investigation (ASI).

CLEAN-UP AND EQUIPMENT SERVICING

9.08 EQUIPMENT

Equipment used is to be cleaned and serviced as adequately as possible at the scene, ensuring the vehicle inventory is complete. Safe storage of equipment on vehicles must not be overlooked when concluding the operation. Engines on motor driven equipment must be cool, and safe to stow, and each item is secured in its correct location. Power units are to be refueled and ready for use. The unit must maintain a continual state of readiness for immediate response.

- 9.09** It is imperative that crews, on return to their Station/Headquarters, carry out a vehicle and equipment service to maintain total operational readiness.

9.10 HYGIENE

Personal hygiene should be addressed at this stage. Body fluids which have come into contact with rescuers or equipment should be decontaminated as indicated in the Communicable Diseases segment in Chapter 6 of this Manual, or as per agency/state/territory requirements.

REPORTS

- 9.11** It is essential that incident reports are completed as soon as practical, while details are still clear.

OPERATIONAL DEBRIEF

9.12 BENEFITS

Operational debriefs are essential, as useful information may result from discussions with members who were at the incident. A properly conducted debrief can contribute to a:

- a. well ordered, satisfied and disciplined team;
- b. clearly defined SOP;
- c. suitably equipped unit;
- d. the relief of stress in team members; and e. review of techniques.

9.13 STRUCTURE

The senior member of the unit, or an appropriate senior person, may conduct the debrief. The debrief should be one of consultancy rather than 'third degree' and should include the following:

- a. The callout—Did the SOP work well?
- b. Travel to the scene—Was it satisfactory?
- c. Hazard assessment and briefing—Was it adequate?
- d. Cooperation with statutory authorities—Was it satisfactory?
- e. Was conduct of the operation generally satisfactory?
- f. Were tools in use adequate?
- g. Were new techniques tried or discovered?
- h. What were members reactions to the whole activity?
- i. Were difficulties encountered?
- j. Summary and undertaking to change if necessary.
- k. Safety aspects of the operation from preparation to termination.

After this information has been gathered, the events should cease to be documented, and an informal discussion continue between team members to allow for a 'Wind-Down' period. A suggested Debrief Check List is included as Annex A.

CRITICAL INCIDENT STRESS DEBRIEF (CISD)

9.14 CIS can be described as any situation faced by rescue service personnel that causes them to experience unusually strong emotional reactions which have the potential to interface with their ability to function either at the scene or later.

9.15 WHY DO WE NEED CISD?

Rescue Officers have well developed coping mechanisms and normally handle the day to day situations well. However, from time to time there may be a job that causes rescuers to think and feel quite differently from the others that they have attended. Some of the thoughts and feelings experienced may include: not being able to stop thinking about the scene, difficulty in sleeping, flashbacks or dreams of the scene, frustration, digestive problems, becoming withdrawn, headaches, and a general feeling of pre-occupation.

9.16 A well structured operational debrief may be all that is required to maintain operational efficiency. However, an operational debrief should never be confused with, or conducted as a CIS debrief. They are separate entities. All rescuers need to be aware of changes in behavioural patterns of individuals and the symptoms relating to emotional stability and conditions. These may require a rescue team leader to encourage rescuers to seek professional

counselling. Information relating to identifying symptoms and the processes of initiating counselling or CISD are identified within each organisation.

- 9.17** As part of pre-planning and ongoing training, existence of local Critical Incident Stress Management teams should be established. They will provide advice on types of assistance they can provide.
- 9.18** The Australian Critical Incident Stress Association will advise on locations and contact numbers for CISM teams in your area. Phone 016080 and quote pager number 844041, leaving your name and contact number. A local CISM team contact number will then be provided promptly. Local government authorities and hospitals can also provide contact details.

DEBRIEF CHECK LIST

The following points should be covered in the operational debrief, with appropriate documentation and follow-up of noted deficiencies.

1. Preparation:

Was the rescue vehicle ready for service? If not, why not? What equipment was not ready for service? Why not? What can be done to improve readiness?

2. Response:

Was all necessary information received about the incident? If not, what was missing? What factors affected response? Was the primary or alternate route used? Why? What special driving skills were required? Was the rescue vehicle safely parked on arrival? If not, what was the danger and how was it handled? What can be done to improve response?

3. Assessment:

Were rescue services required? Was initial response sufficient? If not, what assistance was required? Were all victims immediately accounted for? What steps were taken to locate missing victims? Where were the victims finally found? What can be done to improve assessment?

4. Hazard Control:

What were traffic hazards? What control measures were initiated? What can be done to improve traffic control? What were non-traffic hazards? What control measures were initiated? How can control of non-traffic hazards be improved?

5. Support Operations:

Was the total operation properly coordinated? If not, why not? What support operations were required? Was support sufficient? What can be done to improve support operations?

6. Gaining Access:

Were victims trapped in vehicles? If so, what steps were taken to gain access? What might have been done to gain access more quickly?

7. Emergency Care:

Were victims injured? If so, how? Did rescuers provide first aid care? Could initial care have been improved? If so, how? Did ambulance service require ongoing first aid assistance?

8. Disentanglement:

Was disentanglement necessary? If so, how was it accomplished? How might disentanglement have been improved?

9. Removal and Transfer:

After disentanglement, was the victim ready for transfer? If not, why not? Did the rescue crew assist with removal and transfer? What special equipment was used for removal and transfer? How can removal and transfer activities be improved?

10. Termination:

Was debris removal needed? If so, how was it handled? What continuing support operations were required? Did all rescuers return with the vehicle? If not, why not? Was all equipment replaced on the vehicle? If not, why not? What servicing did the vehicle require? What repairs did the vehicle need? What equipment required repair or maintenance? How was equipment cared for? Is the vehicle ready for service now? If not, why not? What additional equipment could have been carried to improve efficiency in this operation? What additional techniques should rescuers have known to improve performance in this operation?

11. General:

Any other comments relevant to the effective conduct of the rescue operation.